

BAS-311F-0

BAS-311F-L

BAS-326F-0

プログラム式電子ミシン

PROGRAMMABLE ELECTRONIC PATTERN SEWER WITH CYLINDER BED

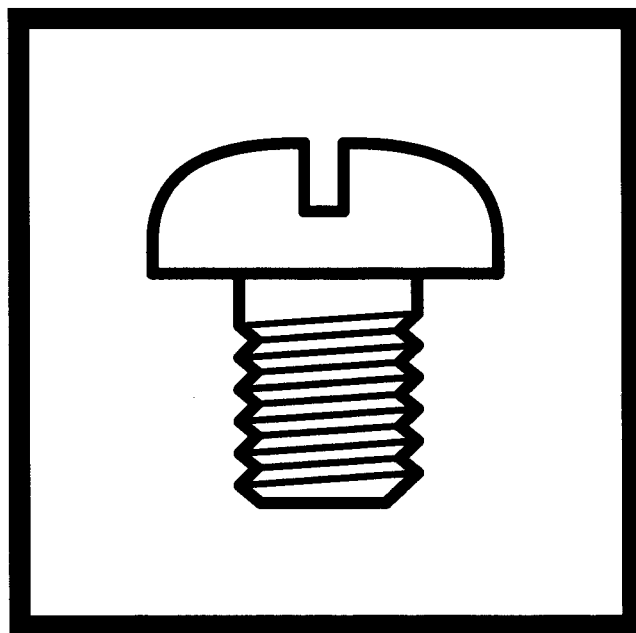

brother[®]

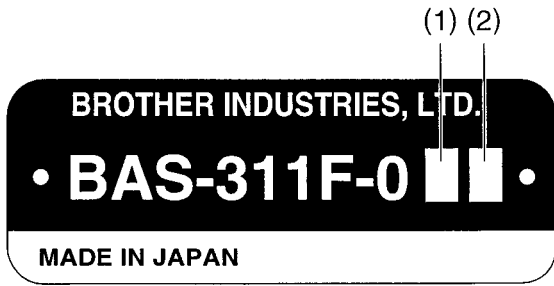

- (1) — 1: 厚物用
For Heavy-weight materials
- 2: 中厚物用
For Medium-weight materials
- 3: 極厚物用
For Extra heavy-weight materials
- 4: 特殊用途用
For Special uses

- (2) — S: 電磁式押え上げ
Work clamp lifter (Solenoid Type)
- A: エア一式押え上げ
Work clamp lifter (Pneumatic Type)



- (3) — 1: 厚物用
For Heavy-weight materials
- 4: 特殊用途用
For Special uses

- (4) — A: エア一式押え上げ
Work clamp lifter (Pneumatic Type)



- (5) — 1: 厚物用
For Heavy-weight materials
- 2: 中厚物用
For Medium-weight materials
- 4: 特殊用途用
For Special uses

- (6) — A: エア一式押え上げ
Work clamp lifter (Pneumatic Type)

パーツブックご利用に際して

1. この本は、2003年7月のデータに基づいて作成されたものです。
2. 部品は予告なしに設計変更される場合があります。
3. 組単位で補給する部品は、 破線で示してあります。

目 次

A1. 主体関係 (311F-0)	1	C14. 送り関係 (326F-0)	45
A2. 主体関係 (311F-L)	3	C15. 送り関係 (326F-0用 オプション部品)	47
A3. 主体関係 (326F-0)	7	D1. 押え上げ関係	49
B1. 上軸・針棒関係	11	D2. 押え上げ関係	51
B2. 上軸・針棒関係	15	E. 下軸関係	53
C1. 送り関係 (311F-0)	17	F. 給油潤滑関係	57
C2. 送り関係 (311F-0)	21	G. 糸通し関係	59
C3. 送り関係 (311F-0)	23	H. 糸巻関係	61
C4. 送り関係 (311F-0, 311F-L用 オプション部品)	25	J. 糸切り関係	63
C5. 送り関係 (311F-0, 311F-L, 326F-0用オプション部品)	27	K. 糸払い関係	67
C6. 送り関係 (311F-0, 311F-L, 326F-0用オプション部品)	29	L. 糸締め関係	69
C7. 送り関係 (311F-0, 311F-L用 オプション部品)	31	M1. 糸取り関係 (311F-0, 311F-L用 オプション部品)	71
C8. 送り関係 (311F-L)	33	M2. 糸取り関係 (326F-0用 オプション部品)	71
C9. 送り関係 (311F-L)	35	N. コントロールボックス関係	73
C10. 送り関係 (311F-L)	37	P. 空圧関係	77
C11. 送り関係 (311F-L用 オプション部品)	39	Q. 電装品関係	81
C12. 送り関係 (326F-0)	41	R. プリント基板関係	85
C13. 送り関係 (326F-0)	43	S. プログラマー関係 (オプション部品)	85
		T. 操作パネル関係	87

<u>U1. 踏板関係</u>	89	<u>AA3. 補助装置関係</u>	
<u>U2. 踏板関係 (オプション部品)</u>	91	<u>(オプション部品)</u>	107
<u>V. 針位置検出器関係</u>	91	<u>AA4. 補助装置関係</u>	
<u>W. 動力台関係</u>	93	<u>(オプション部品)</u>	109
<u>X. ワンタッチ押え装置関係</u>		<u>Z. 付属品関係</u>	113
<u>(オプション部品)</u>	97	<u>Ga1. ゲージ部品一覧表</u>	117
<u>Y1. 中押え反転装置関係 (311F-0,</u>		<u>Ga2. ゲージ部品一覧表 (311F)</u>	119
<u>311F-Lオプション部品)</u>	99	<u>Ga3. ゲージ部品一覧表</u>	
<u>Y2. 中押え反転装置関係 (326F-0</u>		<u>(311Fオプション部品)</u>	121
<u>オプション部品)</u>	101	<u>Ga4. ゲージ部品一覧表</u>	
<u>AA1. 補助装置関係</u>		<u>(311F-Lオプション部品)</u>	123
<u>(オプション部品)</u>	103	<u>Ga5. ゲージ部品一覧表</u>	
<u>AA2. 補助装置関係</u>		<u>(326F-0オプション部品)</u>	125
<u>(オプション部品)</u>	105	<u>Ga6. ゲージ部品一覧表</u>	
		<u>(326F-0オプション部品)</u>	129
		<u>Wa. 警告ラベル</u>	131
		<u>索引</u>	132

Notes for using this parts book

1. This book was prepared based on information available in July 2003.
2. Parts are subject to changes in design without prior notice.
3. Parts supplied as complete assemblies are circled by a dotted line [] .

CONTENTS

<u>A1. Machine body (311F-0)</u>	1	<u>C12. Feed mechanism (326F-0)</u>	41
<u>A2. Machine body (311F-L)</u>	3	<u>C13. Feed mechanism (326F-0)</u>	43
<u>A3. Machine body (326F-0)</u>	7	<u>C14. Feed mechanism (326F-0)</u>	45
<u>B1. Upper shaft and needle bar mechanism</u>	11	<u>C15. Feed mechanism (Option parts of 326F-0)</u>	47
<u>B2. Upper shaft and needle bar mechanism</u>	15	<u>D1. Work clamp lifter mechanism</u>	49
<u>C1. Feed mechanism (311F-0)</u>	17	<u>D2. Work clamp lifter mechanism</u>	51
<u>C2. Feed mechanism (311F-0)</u>	21	<u>E. Lower shaft mechanism</u>	53
<u>C3. Feed mechanism (311F-0)</u>	23	<u>F. Lubrication</u>	57
<u>C4. Feed mechanism (Option parts of 311F-0 & 311F-L)</u>	25	<u>G. Threading mechanism</u>	59
<u>C5. Feed mechanism (Option parts of 311F-0, 311F-L & 326F-0)</u>	27	<u>H. Bobbin winder mechanism</u>	61
<u>C6. Feed mechanism (Option parts of 311F-0, 311F-L & 326F-0)</u>	29	<u>J. Thread trimmer mechanism</u>	63
<u>C7. Feed mechanism (Option parts of 311F-0 & 311F-L)</u>	31	<u>K. Thread wiper mechanism</u>	67
<u>C8. Feed mechanism (311F-L)</u>	33	<u>L. Thread nipper mechanism</u>	69
<u>C9. Feed mechanism (311F-L)</u>	35	<u>M1. Thread take-up mechanism (Option parts of 311F-0 & 311F-L)</u>	71
<u>C10. Feed mechanism (311F-L)</u>	37	<u>M2. Thread take-up mechanism (Option parts of 326F-0)</u>	71
<u>C11. Feed mechanism (Option parts of 311F-L)</u>	39	<u>N. Control box mechanism</u>	73
		<u>P. Air pressure mechanism</u>	77
		<u>Q. Power supply equipment mechanism</u>	81

<u>R. Printed circuit board mechanism</u>	<u>85</u>	<u>AA2. Auxiliary device (Option parts)</u>	<u>105</u>
<u>S. Programmer (Option parts)</u>	<u>85</u>	<u>AA3. Auxiliary device (Option parts)</u>	<u>107</u>
<u>T. Operation panel mechanism</u>	<u>87</u>	<u>AA4. Auxiliary device (Option parts)</u>	<u>109</u>
<u>U1. Foot switch pedal mechanism</u>	<u>89</u>	<u>Z. Accessories</u>	<u>113</u>
<u>U2. Foot switch pedal mechanism</u>		<u>Ga1. Gauge parts list</u>	<u>117</u>
<u>(Option parts)</u>	<u>91</u>	<u>Ga2. Gauge parts list (311F)</u>	<u>119</u>
<u>V. Synchronizer</u>	<u>91</u>	<u>Ga3. Gauge parts list</u>	
<u>W. Power table</u>	<u>93</u>	<u>(Option parts of 311F)</u>	<u>121</u>
<u>X. One-touch work clamp</u>		<u>Ga4. Gauge parts list</u>	
<u>(Option parts)</u>	<u>97</u>	<u>(Option parts of 311F-L)</u>	<u>123</u>
<u>Y1. Inner clamping device</u>		<u>Ga5. Gauge parts list</u>	
<u>(Option parts of 311F-0, 311F-L)</u>	<u>99</u>	<u>(Option parts of 326F-0)</u>	<u>125</u>
<u>Y2. Inner clamping device</u>		<u>Ga6. Gauge parts list</u>	
<u>(Option parts of 326F-0)</u>	<u>101</u>	<u>(Option parts of 326F-0)</u>	<u>129</u>
<u>AA1. Auxiliary device (Option parts)</u>	<u>103</u>	<u>Wa. Warning labels</u>	<u>131</u>
		<u>Index</u>	<u>132</u>

< BAS-311F-0 >

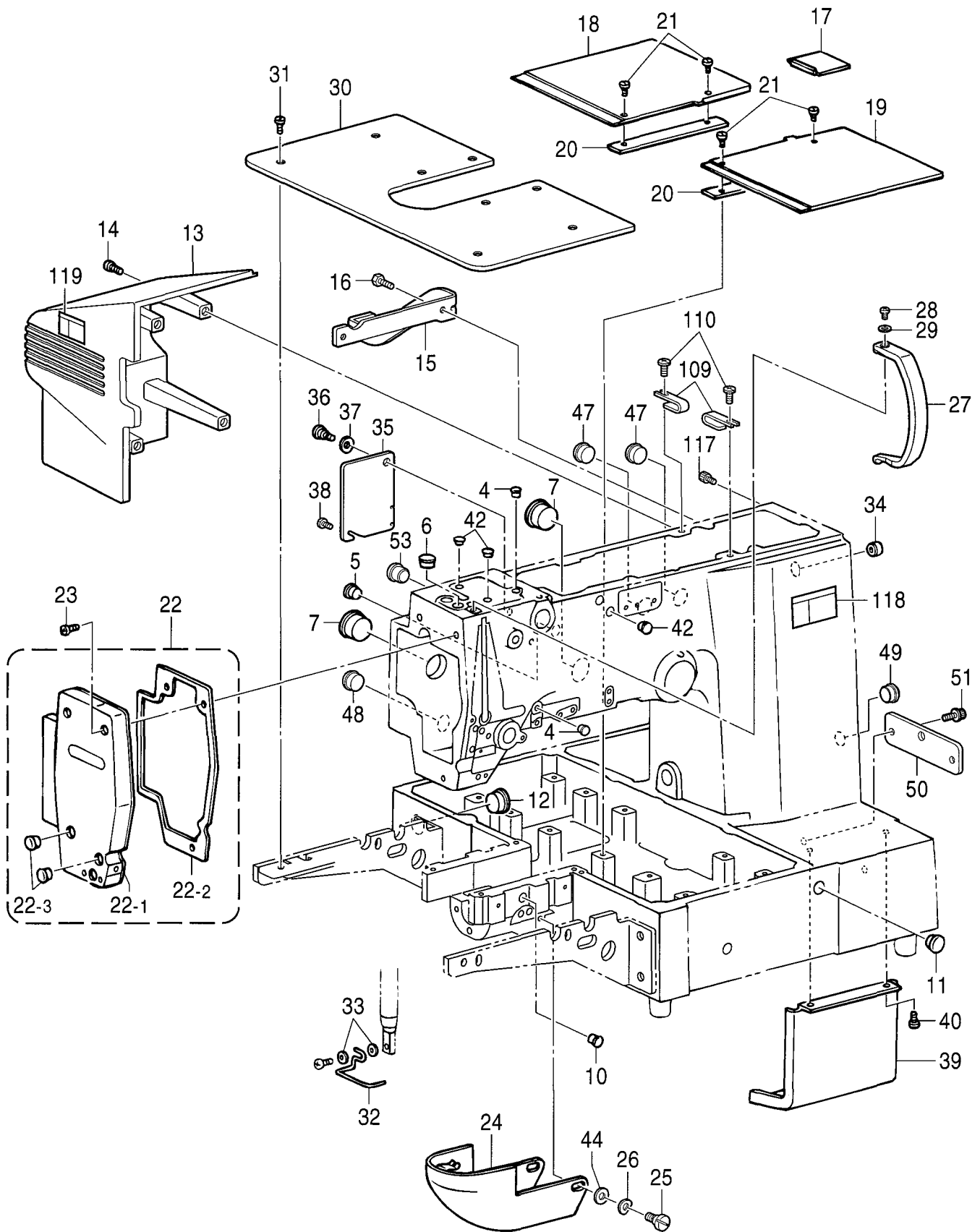

A1.主体関係 (311F-0) / Machine body (311F-0)

REF.NO	CODE	Q'TY	品名	NAME OF PARTS	RM
4	104450101	2	ゴムセン8	RUBBER CAP, 8	
5	104821001	1	ゴムセン10.5	RUBBER CAP, 10.5	
6	117934001	1	ゴムセン13.5	RUBBER CAP, 13.5	
7	140392009	2	オイルフタ	OIL CAP	
10	104450101	1	ゴムセン8	RUBBER CAP, 8	
11	117934001	1	ゴムセン13.5	RUBBER CAP, 13.5	
12	159150000	1	ゴムセン20.5	RUBBER CAP, 20.5	
13	S55191000	1	ソクメンカバー	FRAME SIDE COVER, IM	
14	062711212	4	ナベコ476-32X12	SCREW, PAN SM4.76-32X12	
15	S55152001	1	ソクメンカバーササイタ	HOLDER PLATE	
16	017711412	2	ボルト4.76X14	BOLT, SM4.76X14	
17	S10141109	1	Yオクリダイカバー-B	Y-AXIS FEED BRACKET COVER, B	
18	S42875000	1	Xオクリダイカバー-L	X-AXIS FEED BRACKET COVER, L	
19	S42876000	1	Xオクリダイカバー-R	X-AXIS FEED BRACKET COVER, R	
20	S42877101	2	カバースペース	SPACER, COVER	
21	106629002	4	シメネジ4.37	SCREW, SM4.37	
22	S42750209	1	メンイタクミ	FACE PLATE ASSY	
22-1	S42751109	1	メンイタ	FACE PLATE	
22-2	S42752000	1	メンイタパッキング	F-PLATE PACKING	
22-3	117934001	2	ゴムセン13.5	RUBBER CAP, 13.5	
23	062711012	3	ナベコ476-32X10	SCREW, PAN SM4.76-32X10	
24	S10030002	1	オオカマカバークミ	SHUTTLE RACE COVER ASSY	
25	S57925001	2	ダンネジ6.35	SHOULDER SCREW, SM6.35	
26	109239002	2	ナミハネサガネ	WAVE WASHER	
27	S55208000	1	テンピンカバー	THREAD TAKE-UP LEVER COVER	
28	062681012	1	ナベコ437-40X10	SCREW, PAN SM4.37-40X10	
29	100645003	1	サガネ	WASHER	
30	S55926001	1	311ハリイタホジヨイタ	NEEDLE PLATE AUXILIARY PLATE	
31	106629002	8	シメネジ4.37	SCREW, SM4.37	
32	S02445001	1	フィンガード	FINGER GUARD	
33	025350332	2	ヒラサガネダイ3.5	WASHER, PLAIN L 3.5	
34	S20164001	1	ゴムセン13	RUBBER CAP, 13	
35	S54145001	1	カンケツカバー	STEPPING COVER	
36	107321003	1	ダンネジ4.76	SHOULDER SCREW, SM4.76	
37	107017002	1	ナミハネサガネ	WAVE WASHER	
38	060670612	1	ハインド357-40X6	SCREW, BIND SM3.57-40X6	
39	S42758001	1	SOLアブラウケ	OIL PAN, SOL	
40	062400612	2	ナベコM4X6	SCREW, PAN M4X6	
42	117936001	3	ゴムセン9.4	RUBBER CAP, 9.4	
44	025080132	2	ヒラサガネシヨウ8	WASHER, PLAIN S 8	
47	150592001	2	ゴムセン16	RUBBER CAP, 16	
48	150592001	1	ゴムセン16	RUBBER CAP, 16	
49	104449001	1	ゴムセン15.5	RUBBER CAP, 15.5	
50	S56527001	1	ハネカケササイタ	HOLDER PLATE	
51	S55486001	2	アナボルトサクミ5X14	BOLT, SOCKET (S/P WASHER)M5X14	
53	150592001	1	ゴムセン16	RUBBER CAP, 16	
109	S02704001	2	コードオサエ	CORD HOLDER	
110	060681212	2	ハインド437-40X12	SCREW, BIND SM4.37-40X12	
117	018400632	1	アナボルト4X6	BOLT, SOCKET M4X6	
118	S38357002	1	ソウサチユウイラベル(BAS)ワ 52X84	-----	
118	S38571002	1	-----	LABEL,OPERATION (BAS)ENG. 52X84	
119	S38357001	1	ソウサチユウイラベル(BAS)ワ 40X64	-----	
119	S38571001	1	-----	LABEL,OPERATION (BAS)ENG. 40X64	

A2 . 主体関係 (311F-L) / Machine body (311F-L)

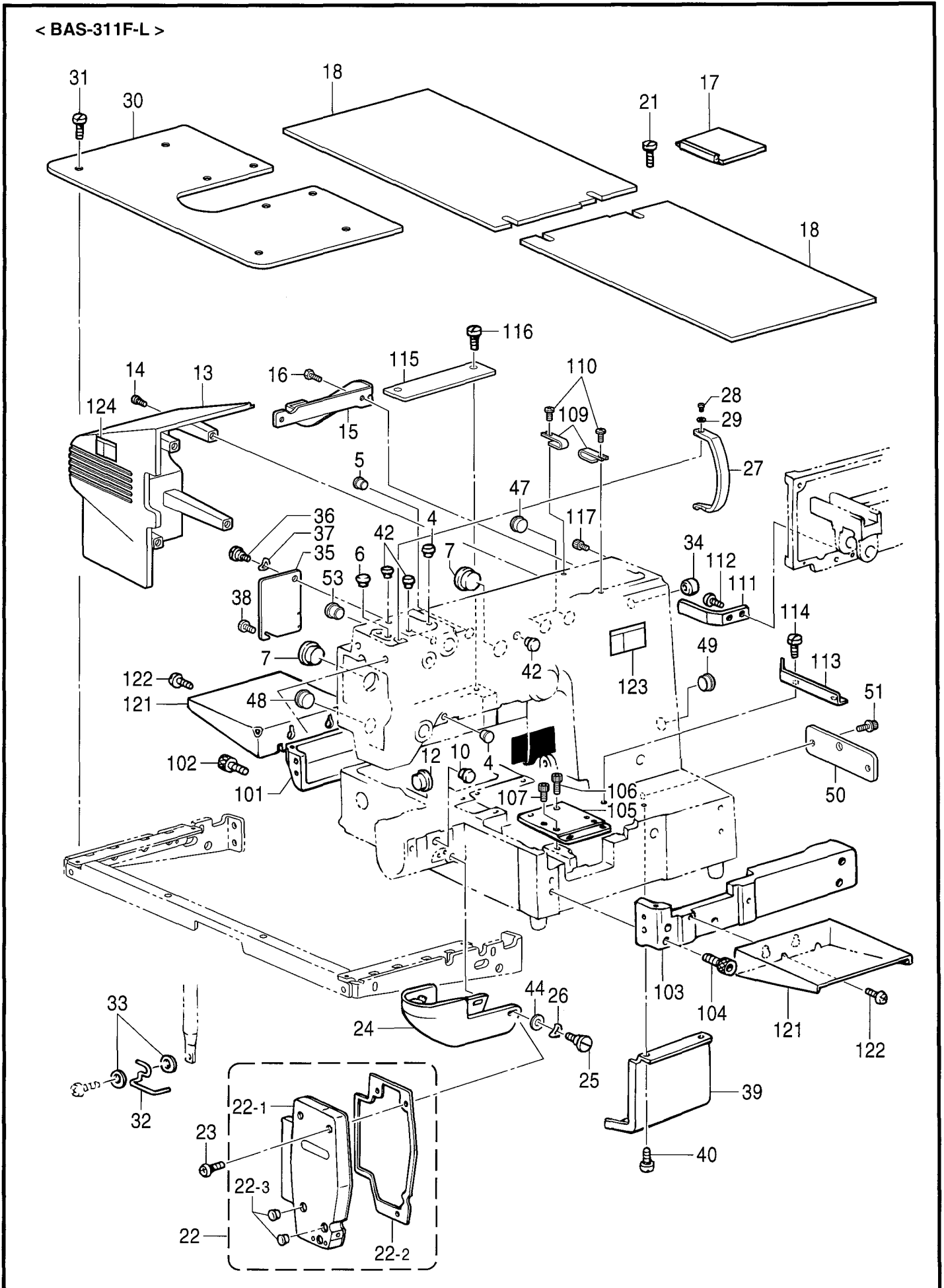

BAS-311F-L-050

A2.主体関係 (311F-L) / Machine body (311F-L)

REF.NO	CODE	Q'TY	品名	NAME OF PARTS	RM
4	104450101	2	ゴムセン8	RUBBER CAP, 8	
5	104821001	1	ゴムセン10.5	RUBBER CAP, 10.5	
6	117934001	1	ゴムセン13.5	RUBBER CAP, 13.5	
7	140392009	2	オイルフタ	OIL CAP	
10	104450101	1	ゴムセン8	RUBBER CAP, 8	
12	159150000	1	ゴムセン20.5	RUBBER CAP, 20.5	
13	S55191000	1	ソクメンカバー	FRAME SIDE COVER, IM	
14	062711212	4	ナベコ476-32X12	SCREW, PAN SM4.76-32X12	
15	S55152001	1	ソクメンカバー-ササエ	HOLDER PLATE	
16	017711412	2	ボルト4.76X14	BOLT, SM4.76X14	
17	S10141109	1	Yオクリダイカバー-B	Y-AXIS FEED BRACKET COVER, B	
18	S55928000	2	Xオクリダイカバー	X-AXIS FEED BRACKET COVER	
21	106629002	4	シメネジ4.37	SCREW, SM4.37	
22	S42750209	1	メンイタクミ	FACE PLATE ASSY	
22-1	S42751109	1	メンイタ	FACE PLATE	
22-2	S42752000	1	メンイタパッキング	F-PLATE PACKING	
22-3	117934001	2	ゴムセン13.5	RUBBER CAP, 13.5	
23	062711012	3	ナベコ476-32X10	SCREW, PAN SM4.76-32X10	
24	S10030002	1	オオカマカバー-グミ	SHUTTLE RACE COVER ASSY	
25	S57925001	2	ダンネジ6.35	SHOULDER SCREW, SM6.35	
26	109239002	2	ナミハネサガネ	WAVE WASHER	
27	S55208000	1	テンピンカバー	THREAD TAKE-UP LEVER COVER	
28	062681012	1	ナベコ437-40X10	SCREW, PAN SM4.37-40X10	
29	100645003	1	サガネ	WASHER	
30	S55929001	1	311Lハリイタホシヨイタ	AUXILIARY PLATE, 311L	
31	106629002	10	シメネジ4.37	SCREW, SM4.37	
32	S02445001	1	フィンガーガード	FINGER GUARD	
33	025350332	2	ヒラサガネダイ3.5	WASHER, PLAIN L 3.5	
34	S20164001	1	ゴムセン13	RUBBER CAP, 13	
35	S54145001	1	カンケツカバー	STEPPING COVER	
36	107321003	1	ダンネジ4.76	SHOULDER SCREW, SM4.76	
37	107017002	1	ナミハネサガネ	WAVE WASHER	
38	060670612	1	ハインド357-40X6	SCREW, BIND SM3.57-40X6	
39	S42758001	1	SOLアブラウケ	OIL PAN, SOL	
40	062400612	2	ナベコM4X6	SCREW, PAN M4X6	
42	117936001	3	ゴムセン9.4	RUBBER CAP, 9.4	
44	025080132	2	ヒラサガネシヨウ8	WASHER, PLAIN S 8	
47	150592001	2	ゴムセン16	RUBBER CAP, 16	
48	150592001	1	ゴムセン16	RUBBER CAP, 16	
49	104449001	1	ゴムセン15.5	RUBBER CAP, 15.5	
50	S56527001	1	ハネカケササエ	HOLDER PLATE	
51	S55486001	2	アナホルトサクミ5X14	BOLT, SOCKET (S/P WASHER)M5X14	
53	150592001	1	ゴムセン16	RUBBER CAP, 16	
101	S44626009	1	ベッド311L-L	BED, 311 L-L	
102	018082032	4	アナホルト8X20	BOLT, SOCKET M8X20	
103	S44605009	1	ベッド311L-R	BED, 311L-R	
104	018082032	4	アナホルト8X20	BOLT, SOCKET M8X20	
105	S44606001	1	XプーリタイスペーサL	SPACER, L	
106	018501632	2	アナホルト5X16	BOLT, SOCKET M5X16	
107	018501232	2	アナホルト5X12	BOLT, SOCKET M5X12	
109	S02704001	2	コードオサエ	CORD HOLDER	
110	060681212	2	ハインド437-40X12	SCREW, BIND SM4.37-40X12	
111	S56539001	1	YカバーガイドイタL	Y-COVER GUIDE PLATE, L	
112	062400812	2	ナベコ4X8	SCREW, PAN M4X8	
113	S44611001	1	YカバーガイドイタR	GUIDE PLATE, R	
114	106629002	2	シメネジ4.37	SCREW, SM4.37	
115	S55930001	1	ベッドカバー-LR	BED COVER, LR	
116	106629002	2	シメネジ4.37	SCREW, SM4.37	
117	018400632	1	アナホルト4X6	BOLT, SOCKET M4X6	
121	S44607001	2	オクリダイカバー-ササエ	FEED BAR COVER SUPPORT	
122	062761012	4	ナベコ595-28X10	SCREW, PAN SM5.95-28X10	

BAS-311F-L-050

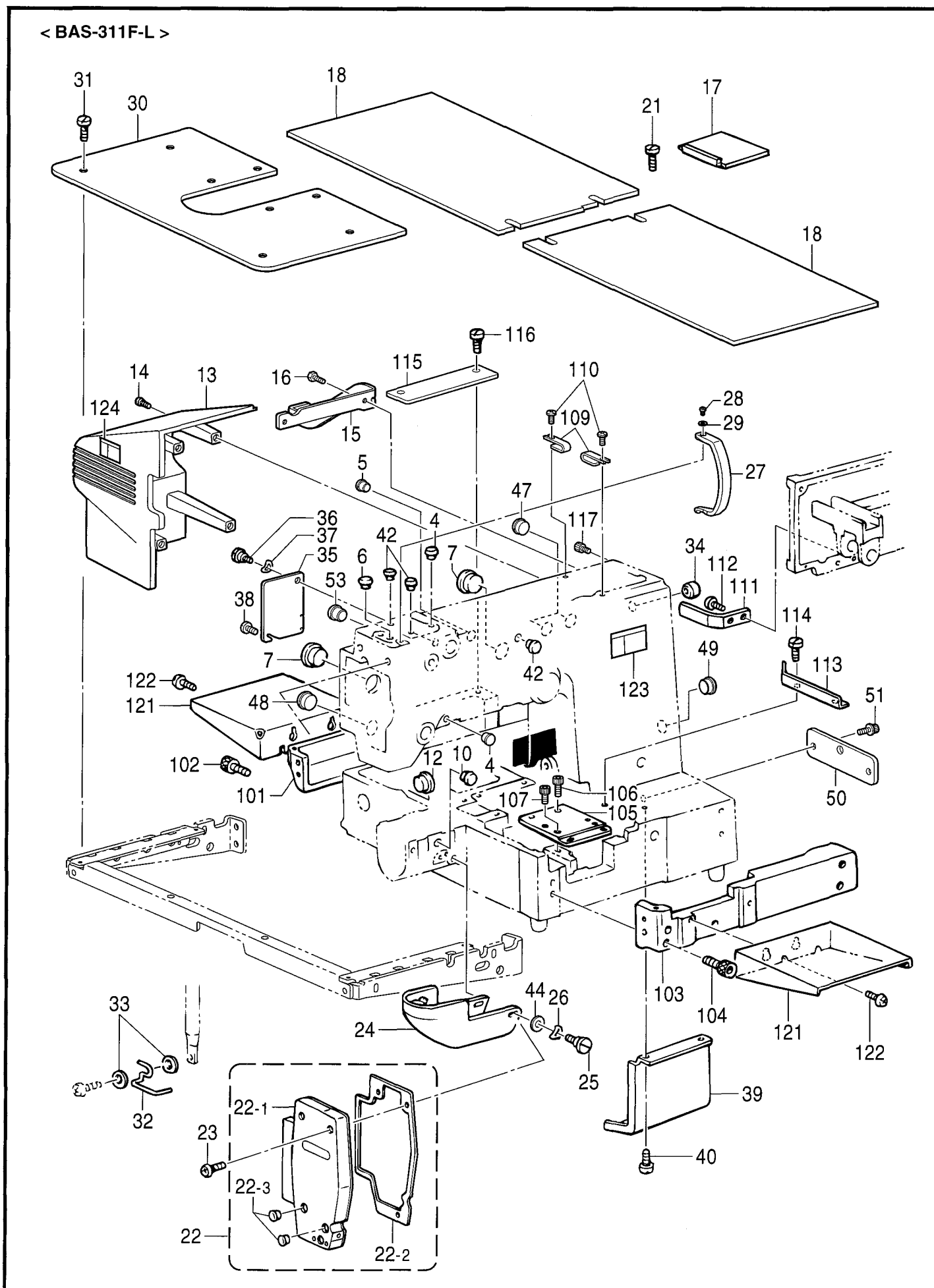

A2.主体関係 (311F-L) / Machine body (311F-L)

REF.NO	CODE	Q'TY	品名	NAME OF PARTS	RM
123	S38357002	1	ソウサチユウイラベル(BAS)7 52X84	-----	
123	S38571002	1	-----	LABEL,OPERATION (BAS)ENG. 52X84	
124	S38357001	1	ソウサチユウイラベル(BAS)7 40X64	-----	
124	S38571001	1	-----	LABEL,OPERATION (BAS)ENG. 40X64	

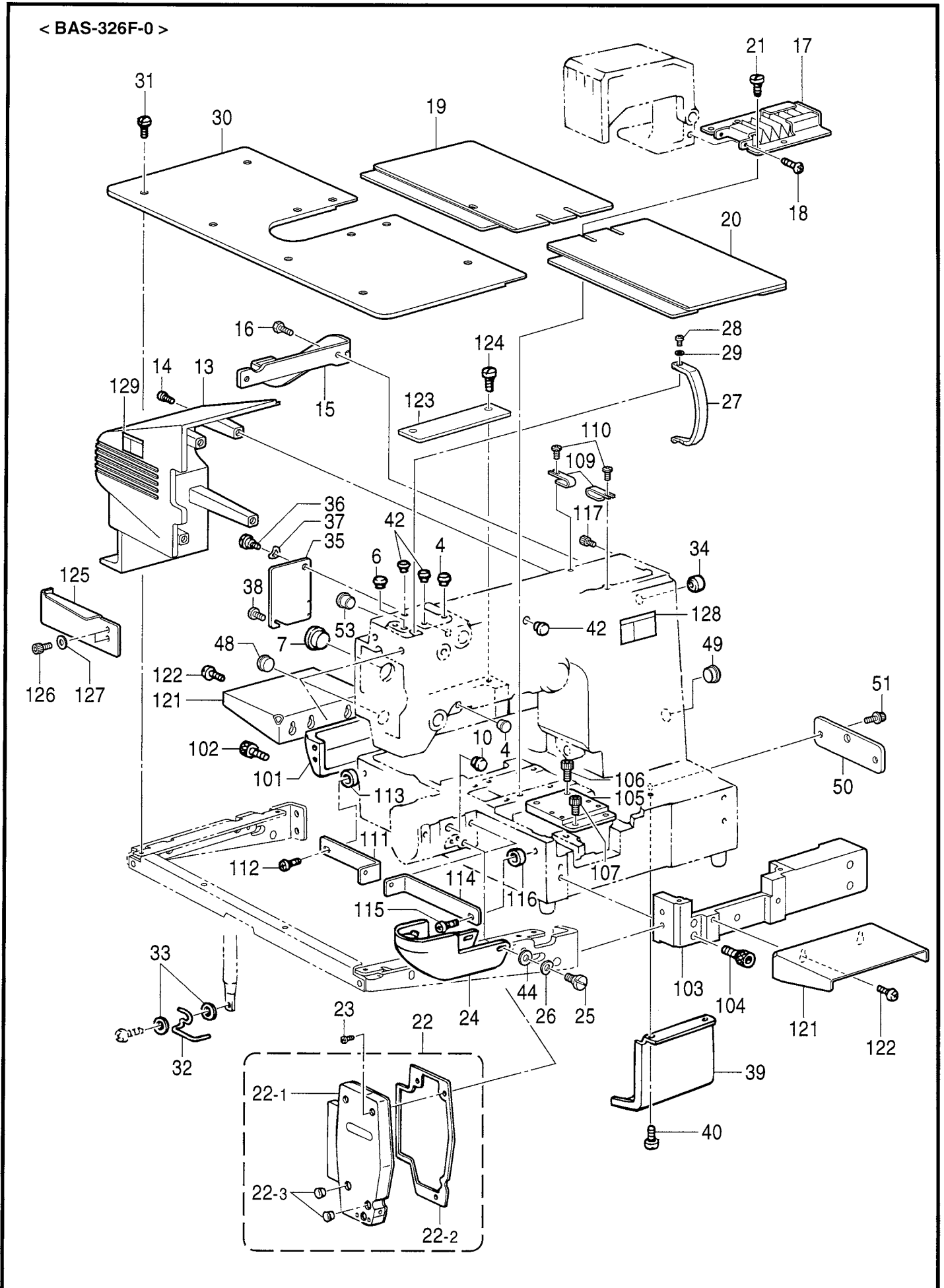

A3.主体関係 (326F-0) / Machine body (326F-0)

REF.NO	CODE	Q'TY	品名	NAME OF PARTS	RM
4	104450101	2	ゴムセン8	RUBBER CAP, 8	
6	117934001	1	ゴムセン13.5	RUBBER CAP, 13.5	
7	140392009	1	オイルフタ	OIL CAP	
10	104450101	1	ゴムセン8	RUBBER CAP, 8	
13	S56530000	1	ソクメンカバー	FRAME SIDE COVER	
14	062711212	4	ナベコ476-32X12	SCREW, PAN SM4.76-32X12	
15	S55152001	1	ソクメンカバーササエ	HOLDER PLATE	
16	017711412	2	ホルト4.76X14	BOLT, SM4.76X14	
17	S44313101	1	シヤバラクミ	BELLOW ASSY	
18	062680612	2	ナベコ4.37-40X6	SCREW, PAN SM4.37-40X6	
19	S48534009	1	Xオクリダイカバー-Lクミ	X-FEED BRACKET COVER ASSY, L	
20	S48537009	1	Xオクリダイカバー-Rクミ	X-FEED BRACKET COVER ASSY, R	
21	106629002	4	シメネジ4.37	SCREW, SM4.37	
22	S42750209	1	メンイタクミ	FACE PLATE ASSY	
22-1	S42751109	1	メンイタ	FACE PLATE	
22-2	S42752000	1	メンイタパツキン	F-PLATE PACKING	
22-3	117934001	2	ゴムセン13.5	RUBBER CAP, 13.5	
23	062711012	3	ナベコ476-32X10	SCREW, PAN SM4.76-32X10	
24	S10030002	1	オオカマカバークミ	SHUTTLE RACE COVER ASSY	
25	S57925001	2	ダンネジ6.35	SHOULDER SCREW, SM6.35	
26	109239002	2	ナミハネサガネ	WAVE WASHER	
27	S55208000	1	テンピンカバー	THREAD TAKE-UP LEVER COVER	
28	062681012	1	ナベコ437-40X10	SCREW, PAN SM4.37-40X10	
29	100645003	1	サガネ	WASHER	
30	S55944001	1	326ハリイタホジヨイタ	AUXILIARY PLATE, 326	
31	106629002	10	シメネジ4.37	SCREW, SM4.37	
32	S02445001	1	フィンガーガード	FINGER GUARD	
33	025350332	2	ヒラサガネダイ3.5	WASHER, PLAIN L 3.5	
34	S20164001	1	ゴムセン13	RUBBER CAP, 13	
35	S54145001	1	カンケツカバー	STEPPING COVER	
36	107321003	1	ダンネジ4.76	SHOULDER SCREW, SM4.76	
37	107017002	1	ナミハネサガネ	WAVE WASHER	
38	060670612	1	ハインド357-40X6	SCREW, BIND SM3.57-40X6	
39	S42758001	1	SOLアブラウケ	OIL PAN, SOL	
40	062400612	2	ナベコM4X6	SCREW, PAN M4X6	
42	117936001	3	ゴムセン9.4	RUBBER CAP, 9.4	
44	025080132	2	ヒラサガネシヨウ8	WASHER, PLAIN S 8	
48	150592001	1	ゴムセン16	RUBBER CAP, 16	
49	104449001	1	ゴムセン15.5	RUBBER CAP, 15.5	
50	S56527001	1	ハネカケササエ	HOLDER PLATE	
51	S55486001	2	アナホルトサクミ5X14	BOLT, SOCKET (S/P WASHER)M5X14	
53	150592001	1	ゴムセン16	RUBBER CAP, 16	
101	S44317009	1	ベット326L	BED, 326 L	
102	018082032	4	アナホルト8X20	BOLT, SOCKET M8X20	
103	S48540109	1	ベット326EL-R	BED, 326EL-R	
104	018082032	4	アナホルト8X20	BOLT, SOCKET M8X20	
105	S44606001	1	Xフリータイスベール	SPACER, L	
106	018501632	2	アナホルト5X16	BOLT, SOCKET M5X16	
107	018501232	2	アナホルト5X12	BOLT, SOCKET M5X12	
109	S02704001	2	コードオサエ	CORD HOLDER	
110	060681212	2	ハインド437-40X12	SCREW, BIND SM4.37-40X12	
111	S44320101	1	ベットカバー-LF	BED COVER, LF	
112	060681212	1	ハインド437-40X12	SCREW, BIND SM4.37-40X12	
113	S19736001	1	カラ-4.5	COLLAR, 4.5	
114	S44321101	1	ベットカバー-RF	BED COVER, RF	
115	060681212	1	ハインド437-40X12	SCREW, BIND SM4.37-40X12	
116	S19736001	1	カラ-4.5	COLLAR, 4.5	
117	018400632	1	アナホルト4X6	BOLT, SOCKET M4X6	
121	S44322101	2	オクリダイカバーササエ	FEED BAR COVER SUPPORT	
122	062761012	4	ナベコ595-28X10	SCREW, PAN SM5.95-28X10	
123	S55930001	1	ベットカバー-LR	BED COVER, LR	

BAS-326F-0-050

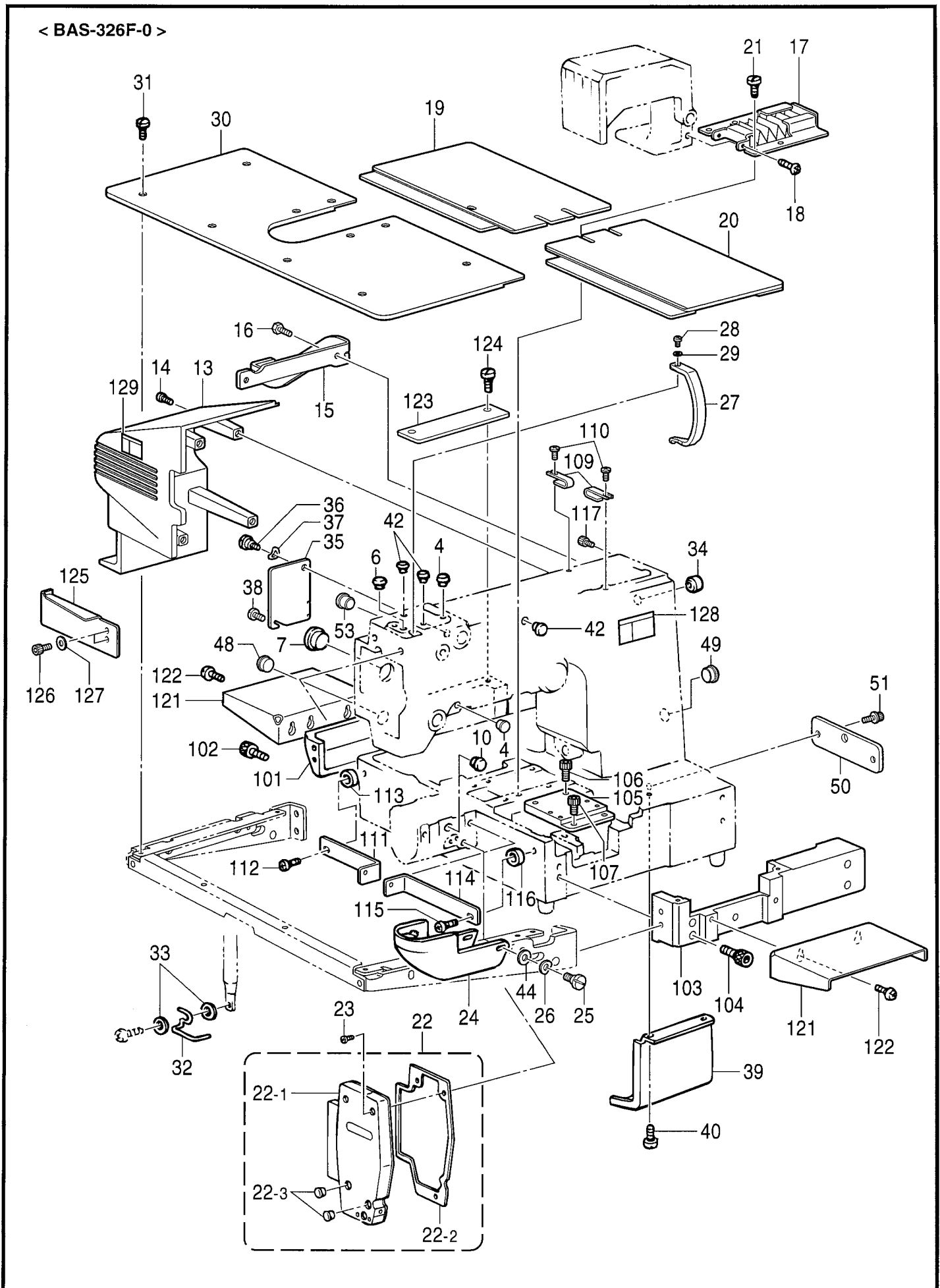

A3.主体関係 (326F-0) / Machine body (326F-0)

REF.NO	CODE	Q'TY	品名	NAME OF PARTS	RM
124	106629002	2	シメネジ4.37	SCREW, SM4.37	
125	S55945001	1	ソクメンカバー-Fカバー	FRAME SIDE COVER, F	
126	018501036	2	アナホルト5X10	BOLT, SOCKET M5X10	
127	025050236	2	ヒラサガネチユウ5	WASHER, PLAIN M 5	
128	S38357002	1	ソウサチユウイラベル(BAS)ワ 52X84	-----	
128	S38571002	1	-----	LABEL,OPERATION (BAS)ENG. 52X84	
129	S38357001	1	ソウサチユウイラベル(BAS)ワ 40X64	-----	
129	S38571001	1	-----	LABEL,OPERATION (BAS)ENG. 40X64	

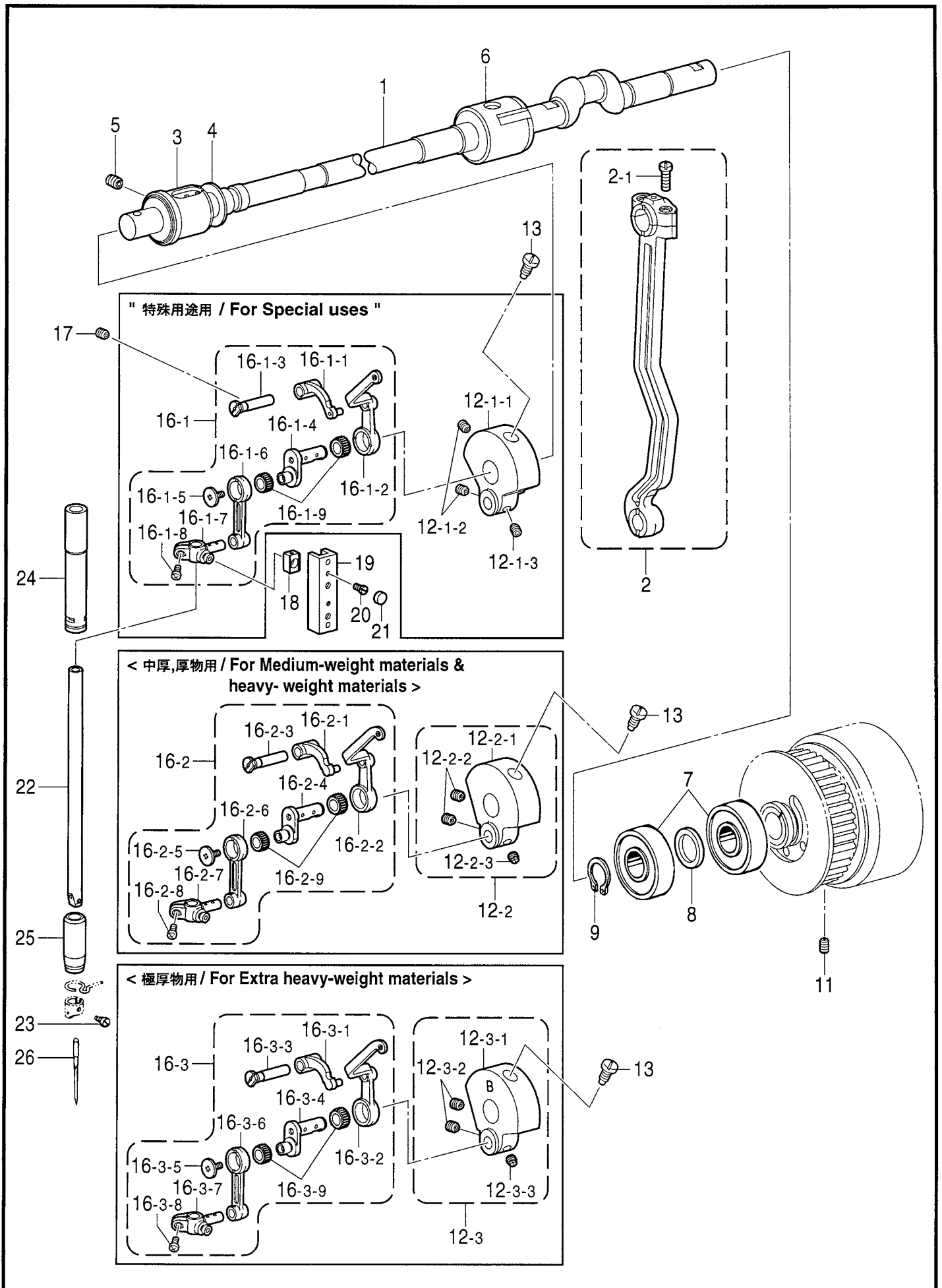

B1.上軸・針棒関係 / Upper shaft and needle bar mechanism

REF.NO	CODE	Q'TY	品名	NAME OF PARTS	RM
1	S55103101	1	ウワシク	UPPER SHAFT	
2	S55145001	1	クランクロッドクミ	CRANK ROD ASSY	
2-1	144712001	2	シメネジ 4.76	SCREW, SM4.76	
3	S49582001	1	ウワシクメタルF	UPPER SHAFT BUSH, F	
4	S55104001	1	スラストサガネ	THRUST WASHER	
5	014780632	1	アナクホミ635-28X6	SET SCREW, SOCKET SM6.35-28X6	
6	140726000	1	ウワシクメタルM	UPPER SHAFT BUSH, M	
7	072630260	2	ベアリング 6302VV	BALL BEARING, 6302VV	
8	116920001	1	オクリシクスラストリング	RING, THRUST	
9	048150142	1	トメワシクヨウC15	RETAINING RING, EXTERNAL C15	
11	S55572001	2	アナクホミ595-28X10	SET SCREW, SOCKET(CP)SM5.95X10	
			<特殊用途用>	<For Special uses>	
12-1-2	014770632	2	アナクホミ635-40X6	SET SCREW, SOCKET(CP) SM6.35X6	
12-1-3	S55877001	1	トメネジ 6.35クホミ	SET SCREW, (CP) SM6.35-40X4	
13	100250001	1	シメネジ 7.14	SCREW, SM7.14	
16-1	S55105001	1	ハリホウレンカンクミ	NEEDLE BAR CONNECTING ROD ASSY	
16-1-1	S49587001	1	テンビンササエ	THREAD TAKE-UP SUPPORT	
16-1-2	S49588001	1	テンビントウ	THREAD TAKE-UP LEVER	
16-1-3	S47091001	1	テンビンササエジク	THREAD TAKE-UP SUPPORT SHAFT	
16-1-4	S49589001	1	ハリホウクランク	NEEDLE BAR CRANK	
16-1-5	145465001	1	シメネジ 3.57L	SCREW, SM3.57-40X6 L	
16-1-6	S49689001	1	ハリホウレンカン	NEEDLE BAR CONNECTING ROD	
16-1-7	S42756101	1	ハリホウダキ	NEEDLE BAR CLAMP	
16-1-8	062680712	1	ナベコ 437-40X7	SCREW, PAN SM4.73-40X7	
16-1-9	147777000	2	ニードルベアリング	NEEDLE BEARING	
			<中厚、厚物用>	<For Medium-weight materials & heavy-weight materials>	
12-2	S37064101	1	ツリアイクランククミ	THREAD TAKE-UP CRANK	
12-2-1	S10040001	1	テンビークランク	THREAD TAKE-UP CRANK	
12-2-2	014770632	2	アナクホミ635-40X6	SET SCREW, SOCKET(CP) SM6.35X6	
12-2-3	S39973001	1	アナクホミ635-40X5	SET SCREW, SOCKET SM6.35-40X5	
13	100250001	1	シメネジ 7.14	SCREW, SM7.14	
16-2	S55966001	1	ハリホウレンカンAクミ	N-BAR CONNECTING ROD A ASSY	
16-2-1	S47089001	1	テンビンササエ	THREAD TAKE-UP SUPPORT	
16-2-2	S47090001	1	テンビントウ	THREAD TAKE-UP LEVER	
16-2-3	S47091001	1	テンビンササエジク	THREAD TAKE-UP SUPPORT SHAFT	
16-2-4	152237101	1	ハリホウクランク	NEEDLE BAR CRANK	
16-2-5	145465001	1	シメネジ 3.57L	SCREW, SM3.57-40X6 L	
16-2-6	S49689001	1	ハリホウレンカン	NEEDLE BAR CONNECTING ROD	
16-2-7	S42756101	1	ハリホウダキ	NEEDLE BAR CLAMP	
16-2-8	062680712	1	ナベコ 437-40X7	SCREW, PAN SM4.73-40X7	
16-2-9	147777000	2	ニードルベアリング	NEEDLE BEARING	
			<極厚物用>	<For Extra heavy-weight materials>	
12-3	S59134001	1	ツリアイクランクBクミ	COUNTER WEIGHT B	
12-3-1	154623000	1	ツリアイクランクB	THREAD TAKE-UP CRANK, B	
12-3-2	014770632	2	アナクホミ635-40X6	SET SCREW, SOCKET(CP) SM6.35X6	
12-3-3	S55877001	1	トメネジ 6.35クホミ	SET SCREW, (CP) SM6.35-40X4	
13	100250001	1	シメネジ 7.14	SCREW, SM7.14	
16-3	S55970001	1	ハリホウレンカンBクミ	N-BAR CONNECTING ROD B ASSY	
16-3-1	S47089001	1	テンビンササエ	THREAD TAKE-UP SUPPORT	
16-3-2	S47090001	1	テンビントウ	THREAD TAKE-UP LEVER	
16-3-3	S47091001	1	テンビンササエジク	THREAD TAKE-UP SUPPORT SHAFT	
16-3-4	154624101	1	ハリホウクランクB	NEEDLE BAR CRANK, B	
16-3-5	145465001	1	シメネジ 3.57L	SCREW, SM3.57-40X6 L	
16-3-6	S49689001	1	ハリホウレンカン	NEEDLE BAR CONNECTING ROD	
16-3-7	S42756101	1	ハリホウダキ	NEEDLE BAR CLAMP	

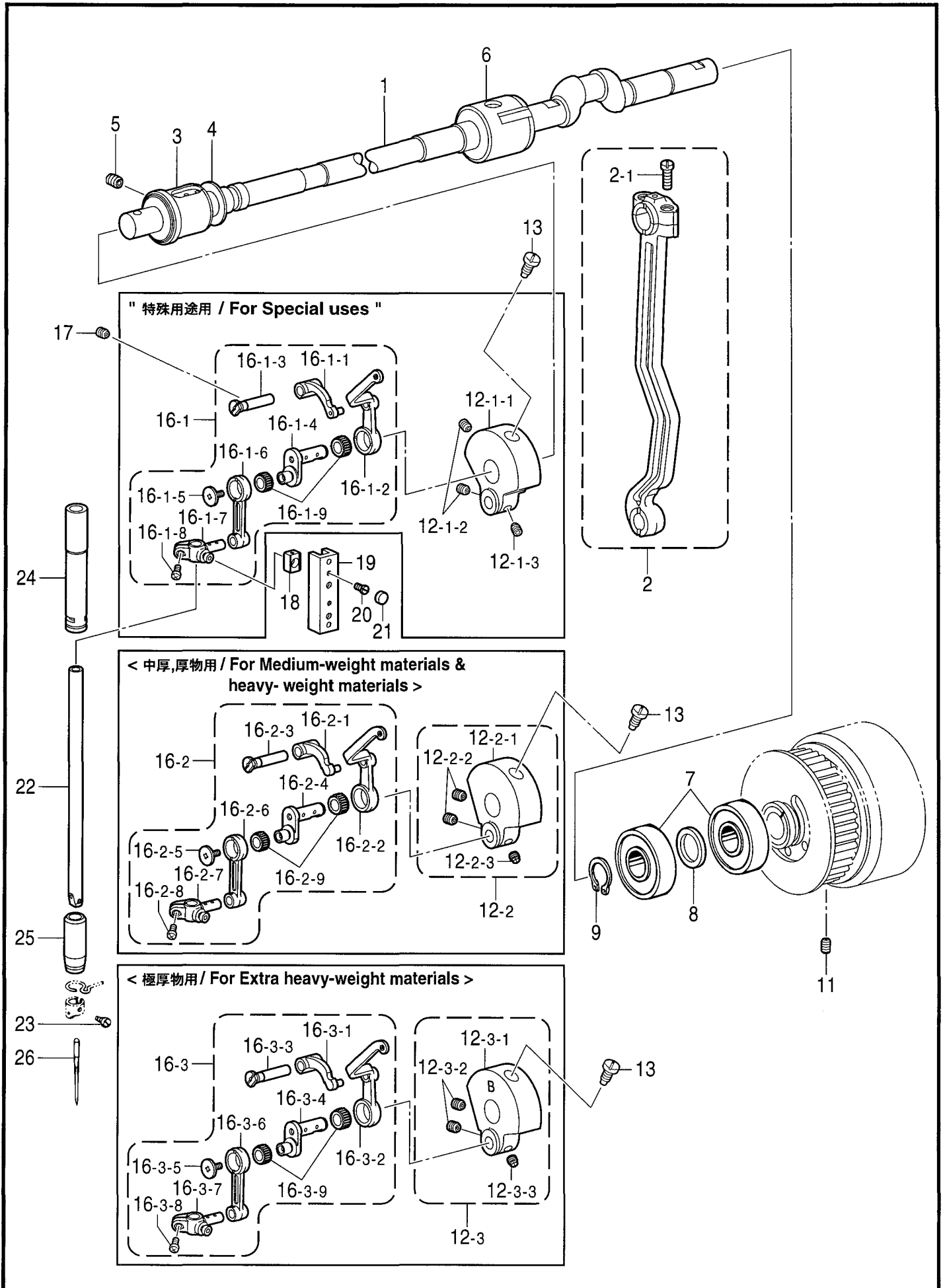

B1.上軸・針棒関係 / Upper shaft and needle bar mechanism

REF.NO	CODE	Q'TY	品名	NAME OF PARTS	RM
16-3-8	062680712	1	ナベコ437-40X7	SCREW, PAN SM4.73-40X7	
16-3-9	147777000	2	ニードルベアリング	NEEDLE BEARING	
17	014780632	1	アナクホミ635-28X6	SET SCREW, SOCKET SM6.35-28X6	
18	102630001	1	ハリホウアンナイカクマ	NEEDLE BAR GUIDE SLIDE BLOCK	
19	S49593000	1	ハリホウアンナイ	NEEDLE BAR GUIDE	
20	100242003	2	シメネジ3.57	SCREW, SM3.57-40X5	
21	155578000	2	ゴムセン7.2	RUBBER CAP, 7.2	
22	S02269001	1	ハリホウ	NEEDLE BAR	
23	144458001	1	アタマツキトメネジ3.57	SET SCREW, SM3.57-40X4.5	
24	152242001	1	ハリホウメタルU	NEEDLE BAR BUSH, U	
25	152243001	1	ハリホウメタルD	NEEDLE BAR BUSH, D	
			< 中厚物用 >	< For Medium-weight materials >	
26	107415016	1	ミシンハリDPX5 (#16)	NEEDLE, DPX5 (#16)	
			< 311F-L厚物用 >	< For Heavy-weight materials of 311F-L >	
26	145646019	1	ミシンハリDPX17 (#19)	NEEDLE, DPX17 (#19)	
			< 311F-0, 326F-0厚物用 >	< For Heavy-weight materials of 311F-0 & 326F-0 >	
26	145646019	1	ミシンハリDPX17 (#19)	NEEDLE, DPX17 (#19)	
			< 極厚物用 >	< For Extra heavy-weight materials >	
26	145646025	1	ミシンハリDPX17 (#25)	NEEDLE, DPX17 (#25)	
			"オプション部品"	"OPTION PARTS"	
26	107415009	1	ミシンハリDPX5 (#9)	NEEDLE, DPX5 (#9)	
26	107415011	1	ミシンハリDPX5 (#11)	NEEDLE, DPX5 (#11)	
26	107415014	1	ミシンハリDPX5 (#14)	NEEDLE, DPX5 (#14)	
26	107415018	1	ミシンハリDPX5 (#18)	NEEDLE, DPX5 (#18)	
26	107415019	1	ミシンハリDPX5 (#19)	NEEDLE, DPX5 (#19)	
26	107415021	1	ミシンハリDPX5 (#21)	NEEDLE, DPX5 (#21)	
26	107415023	1	ミシンハリDPX5 (#23)	NEEDLE, DPX5 (#23)	
26	154763010	1	ミシンハリDPX5KN (#10)	NEEDLE, DPX5KN (#10)	
26	S37929009	1	ミシンハリDPX5NY (#9)	NEEDLE, DPX5NY (#9)	
26	S37929016	1	ミシンハリDPX5NY (#16)	NEEDLE, DPX5NY (#16)	
26	145646011	1	ミシンハリDPX17 (#11)	NEEDLE, DPX17 (#11)	
26	145646014	1	ミシンハリDPX17 (#14)	NEEDLE, DPX17 (#14)	
26	145646016	1	ミシンハリDPX17 (#16)	NEEDLE, DPX17 (#16)	
26	145646018	1	ミシンハリDPX17 (#18)	NEEDLE, DPX17 (#18)	
26	145646024	1	ミシンハリDPX17 (#24)	NEEDLE, DPX17 (#24)	
26	S37928019	1	ミシンハリDPX17NY (#19)	NEEDLE, DPX17NY (#19)	
26	S24511007	1	ミシンハリ3355-01MR (MR7)	NEEDLE, 3355-01 MR7	

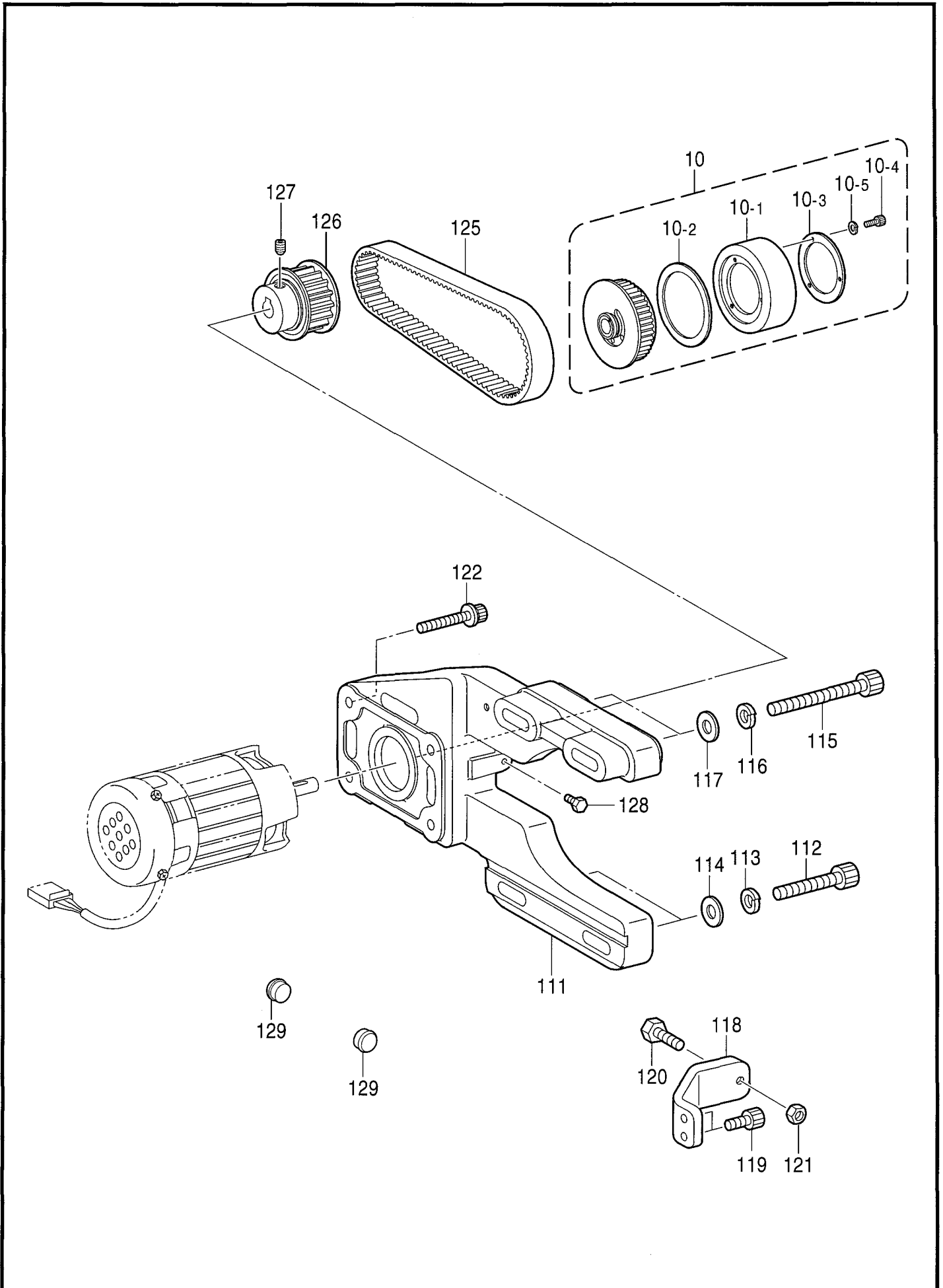

B2.上軸・針棒関係 / Upper shaft and needle bar mechanism

REF.NO	CODE	Q'TY	品名	NAME OF PARTS	RM
10	S57711001	1	Uタイミングプーリ	TIMING PULLEY ASSY, U	
10-1	S57712000	1	ウワシクプーリ	PULLEY, U	
10-2	S56018000	1	プーリスヘーサ	PULLEY SPACER	
10-3	S56019001	1	プーリサガネ	PULLEY WASHER	
10-4	018401236	3	アナホルト4X12	BOLT, SOCKET M4X12	
10-5	028040246	3	ハネサガネ2-4	WASHER, SPRING 2-4	
111	S55198000	1	モータブラケット	MOTOR BRACKET	
112	018084032	2	アナホルト8X40	BOLT, SOCKET M8X40	
113	028080242	2	ハネサガネ2-8	WASHER, SPRING 2-8	
114	025080232	2	ヒラサガネチユウ8	WASHER, PLAIN M 8	
115	018087032	2	アナホルト8X70	BOLT, SOCKET M8X70	
116	028080242	2	ハネサガネ2-8	WASHER, SPRING 2-8	
117	025080232	2	ヒラサガネチユウ8	WASHER, PLAIN M 8	
118	S55197001	1	ベルトチヨウセツイタ	BELT ADJUSTING PLATE	
119	018061232	2	アナホルト6X12	BOLT, SOCKET M6X12	
120	017062012	1	ホルト6X20	BOLT, M6X20	
121	021060102	1	ナツト1シユ6	NUT, 1 M6	
122	S47270001	4	アナホルトサクミ6X30	BOLT, SOCKET (S/P WASHER)M6X30	
125	S55917000	1	ウワシクタイミングベルト	UPPER SHAFT TIMING BELT	
126	S52836000	1	Mタイミングプーリ32クミ	MOTOR TIMING PULLEY 32 ASSY	
127	S55572001	1	アナクホミ595-28X10	SET SCREW, SOCKET(CP)SM5.95X10	
128	017680512	1	ホルト4.37X5	BOLT, SM4.37X5	
129	104450101	2	ゴムセン8	RUBBER CAP, 8	

< 電磁式用 / For Solenoid type >

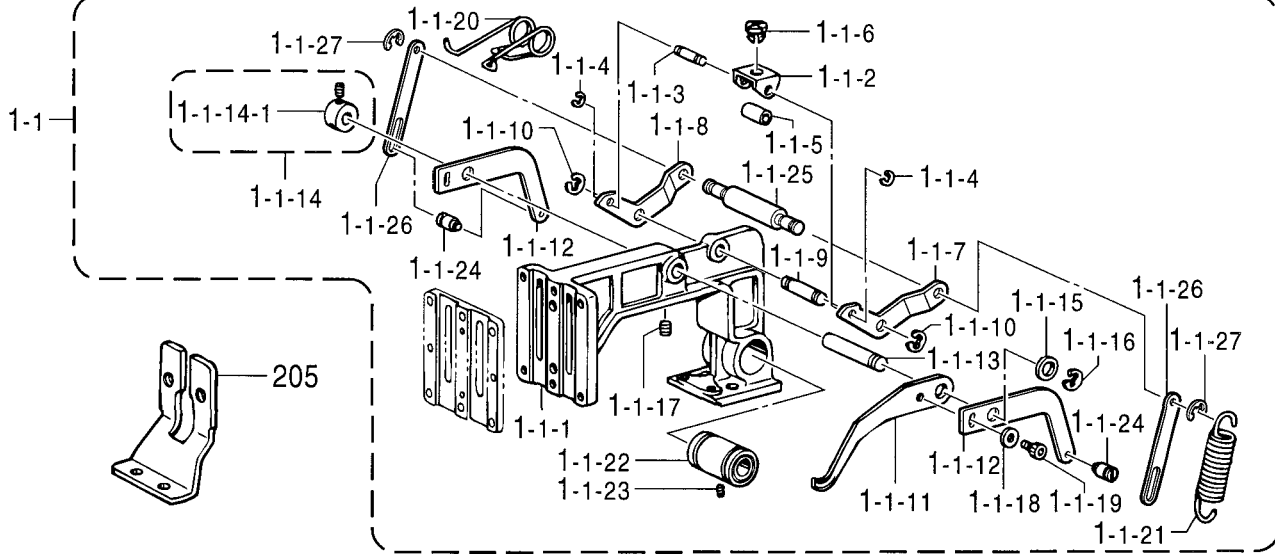

< エアー式用 / For pneumatic type >

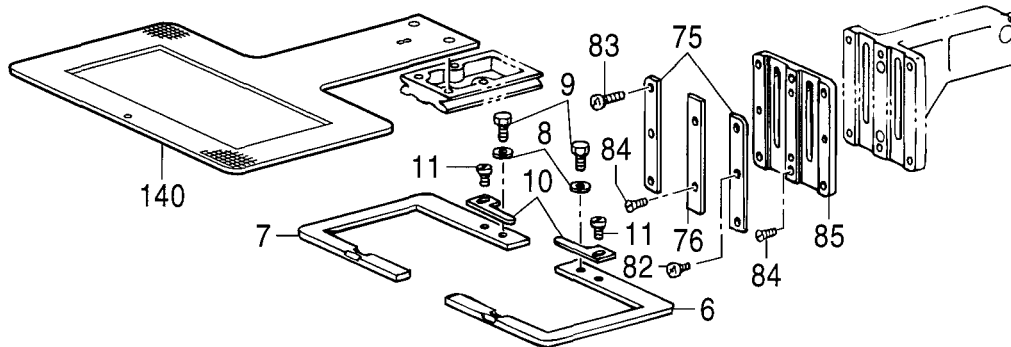
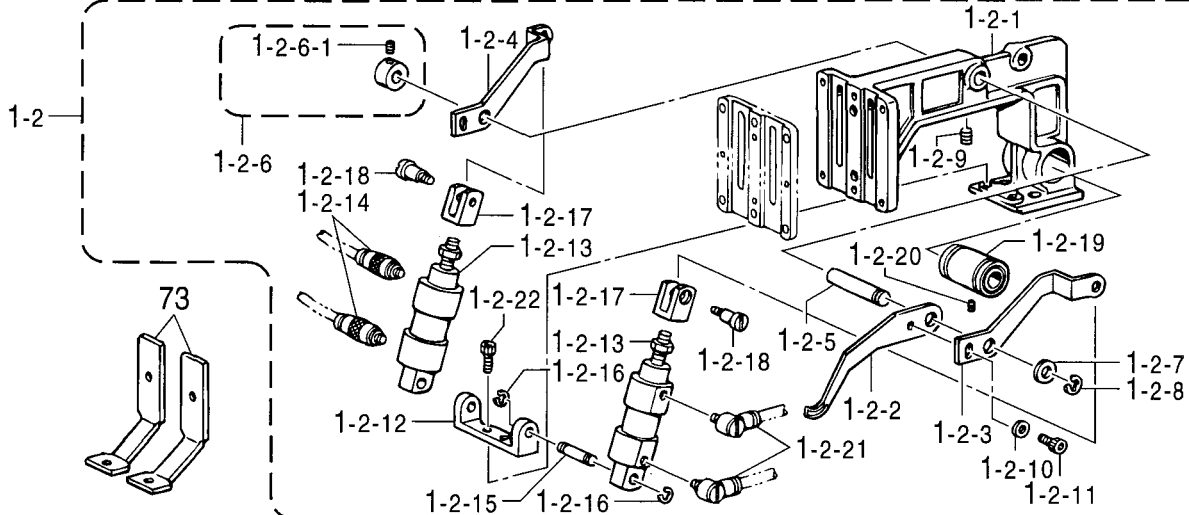

" オプション部品 / OPTION PARTS "

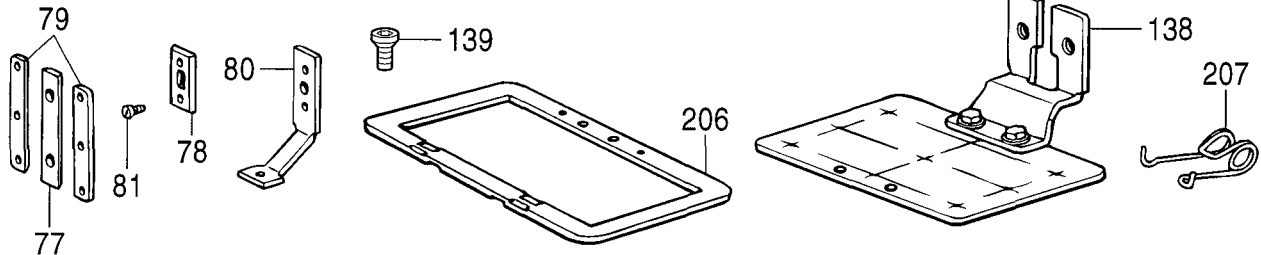

C1.送り関係 (311F-0) / Feed mechanism (311F-0)

REF.NO	CODE	Q'TY	品名	NAME OF PARTS	RM
			<電磁式用>	<For Solenoid type>	
1-1	SA2428001	1	オサエウテ ^ク ミ	WORK CLAMP ASSY, SOL.	
1-1-1	S42761000	1	オサエウテ ^テ	WORK CLAMP ARM	
1-1-2	S10047001	1	スライダ ^ー ササエ	SLIDER SUPPORT	
1-1-3	S10048001	1	スライダ ^ー ササエ ^{シク}	SLIDER SUPPORT SHAFT	
1-1-4	048030342	2	トメ ^ワ E3	RETAINING RING, E3	
1-1-5	S10049001	1	ササエ ^{シク} カンザ ^ク	SPACER	
1-1-6	S10050000	1	スライダ ^ー	SLIDER	
1-1-7	SA2424001	1	オサエアケ ^レ ハ ^ー R	WORK CLAMP LIFTER LEVER, R	
1-1-8	SA2423001	1	オサエアケ ^レ ハ ^ー L	WORK CLAMP LIFTER LEVER, L	
1-1-9	S10053001	1	オサエアケ ^レ ハ ^ー シク	WORK CLAMP LIFTER SHAFT	
1-1-10	048040342	2	トメ ^ワ E4	RETAINING RING, E4	
1-1-11	S42764001	2	オサエウテ ^レ ハ ^ー F	WORK CLAMP ARM LEVER, F	
1-1-12	S55147001	2	オサエウテ ^レ ハ ^ー R	WORK CLAMP ARM LEVER, R	
1-1-13	S10058001	1	オサエウテ ^レ ハ ^ー シク	W-CLAMP ARM LEVER SHAFT	
1-1-14	S21775001	1	セツカ ^ラ ク ^ミ	SET SCREW COLLAR ASSY	
1-1-14-1	014680432	2	アナクホ ^ミ 437-40X4	SET SCREW, SOCKET SM4.37-40X4	
1-1-15	143591001	1	スラスト ^リ ンク ^ク	THRUST RING	
1-1-16	048050342	1	トメ ^ワ E5	RETAINING RING, E5	
1-1-17	014760632	1	アナクホ ^ミ 595-28X6	SET SCREW, SOCKET SM5.95-28X6	
1-1-18	025040232	2	ヒラサ ^カ ネチユ ^ウ 4	WASHER, PLAIN M 4	
1-1-19	018400632	2	アナホ ^{ルト} 4X6	BOLT, SOCKET M4X6	
1-1-20	S10059001	1	オサエウテ ^レ ハ ^ー ハ ^ネ	SPRING	
1-1-21	S42767001	2	オサエ ^ハ ネ	PRESSER BAR SPRING	
1-1-22	S12004000	1	リニア ^ブ ツシユ	LINEAR BUSH	
1-1-23	011679312	1	トメ ^ネ シ ^ク 3.57ヒラ	SET SCREW, (FT) SM3.57	
1-1-24	S55132001	2	オサエ ^ハ ネカケ ^U	SPRING HOOK, U	
1-1-25	SA2427001	1	オサエ ^ハ ネカケ ^D	SPRING HOOK, D	
1-1-26	SA2425001	2	オサエウテ ^リ ンク	WORK CLAMP ARM LEVER	
1-1-27	048060342	2	ダン ^ネ シ ^ク M4	SHOULDER SCREW, M4	
			<エア式用>	<For Pneumatic type>	
1-2	S42768101	1	オサエウテ ^ク ミAIR	WORK CLAMP ARM ASSY, AIR	
1-2-1	S42761000	1	オサエウテ ^テ	WORK CLAMP ARM	
1-2-2	S42764001	2	オサエウテ ^レ ハ ^ー F	WORK CLAMP ARM LEVER, F	
1-2-3	S42769001	1	オサエウテ ^レ ハ ^ー RR-A	WORK CLAMP ARM LEVER, RR-A	
1-2-4	S42770001	1	オサエウテ ^レ ハ ^ー RL-A	WORK CLAMP ARM LEVER, RL-A	
1-2-5	S10058001	1	オサエウテ ^レ ハ ^ー シク	W-CLAMP ARM LEVER SHAFT	
1-2-6	S21775001	1	セツカ ^ラ ク ^ミ	SET SCREW COLLAR ASSY	
1-2-6-1	014680432	2	アナクホ ^ミ 437-40X4	SET SCREW, SOCKET SM4.37-40X4	
1-2-7	143591001	1	スラスト ^リ ンク ^ク	THRUST RING	
1-2-8	048050342	1	トメ ^ワ E5	RETAINING RING, E5	
1-2-9	014760632	1	アナクホ ^ミ 595-28X6	SET SCREW, SOCKET SM5.95-28X6	
1-2-10	025040232	2	ヒラサ ^カ ネチユ ^ウ 4	WASHER, PLAIN M 4	
1-2-11	018400632	2	アナホ ^{ルト} 4X6	BOLT, SOCKET M4X6	
1-2-12	S10379001	1	シリンダ ^サ サエ	CYLINDER SUPPORT	
1-2-13	S42878000	2	エアシリンダ ¹⁵⁻¹⁸	AIR CYLINDER, 15-18	
1-2-14	S18415101	2	ハーフユニオン ^{Q4M5}	HALF UNION :Q4M5	
1-2-15	S03800001	2	クレビス ^ピ ン	CLEVIS PIN	
1-2-16	048040342	4	トメ ^ワ E4	RETAINING RING, E4	
1-2-17	S03801101	2	シリンダ ^ツ キ ^テ	CYLINDER JOINT	
1-2-18	110168001	2	コロ ^シ ク	ROLLER SHAFT	
1-2-19	S12004000	1	リニア ^ブ ツシユ	LINEAR BUSH	
1-2-20	011679312	1	トメ ^ネ シ ^ク 3.57ヒラ	SET SCREW, (FT) SM3.57	
1-2-21	S41271000	2	エルホ ^ウ M5	ELBOW, M5	
1-2-22	018501232	2	アナホ ^{ルト} 5X12	BOLT, SOCKET M5X12	

< 電磁式用 / For Solenoid type >

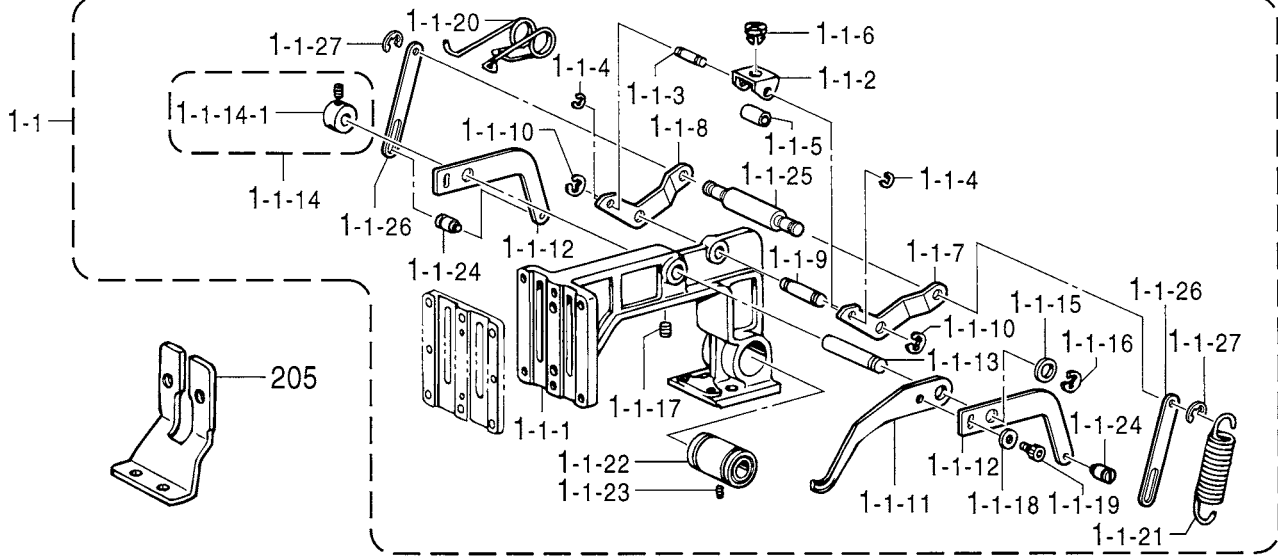

< エアー式用 / For pneumatic type >

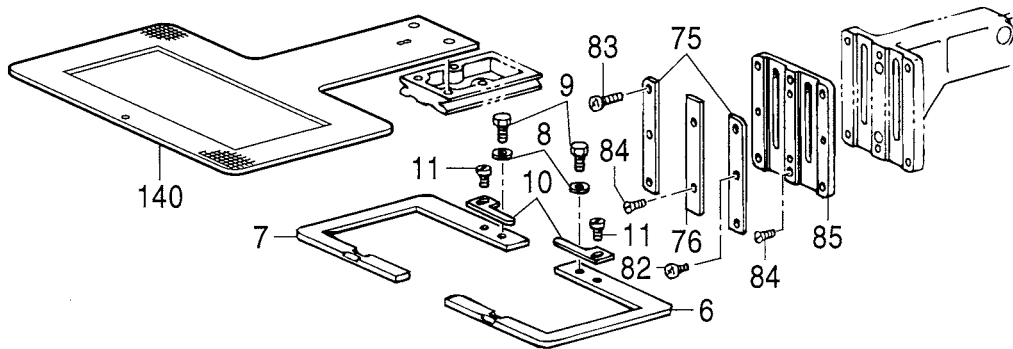
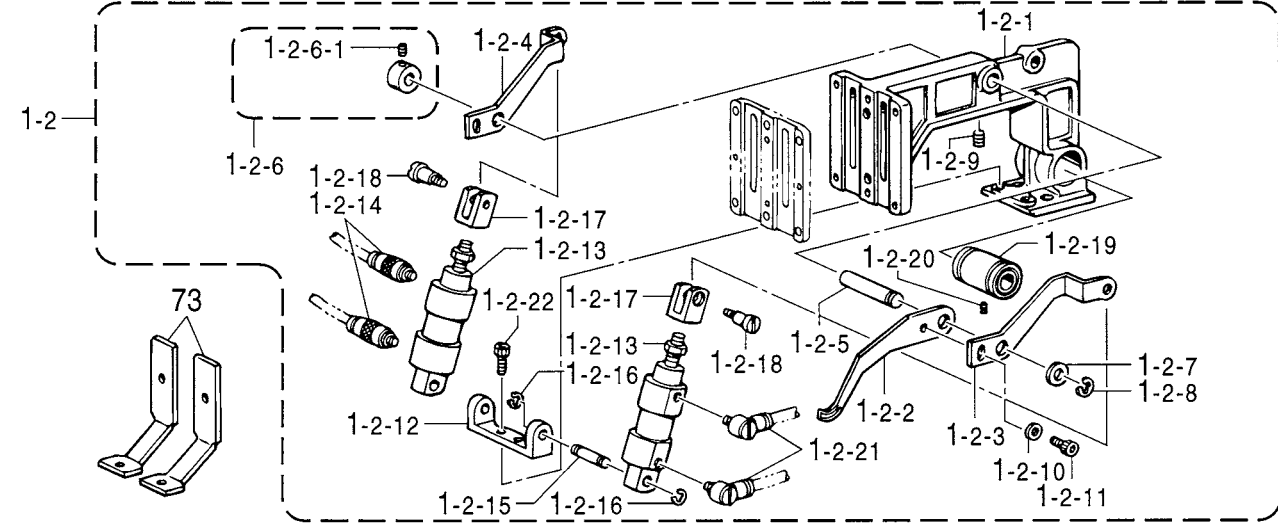

" オプション部品 / OPTION PARTS "

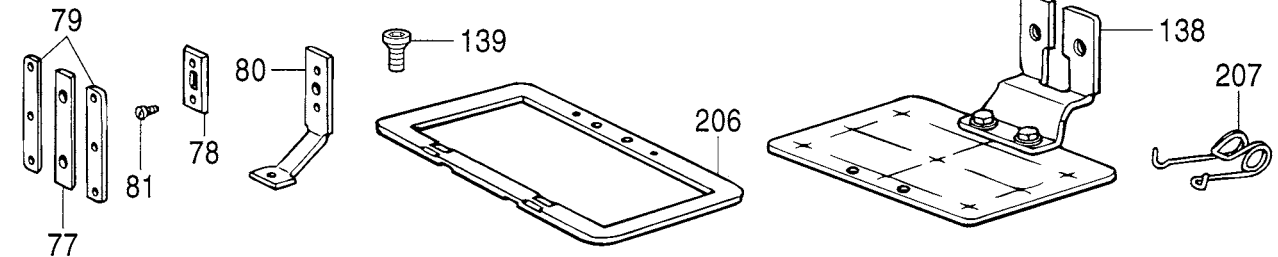

C1.送り関係 (311F-0) / Feed mechanism (311F-0)

REF.NO	CODE	Q'TY	品名	NAME OF PARTS	RM
6	S42772001	1	311オサER	WORK CLAMP, R 311	
7	S42773001	1	311オサEL	WORK CLAMP, L 311	
8	025680232	2	ヒラサカネチユウ4.37	WASHER, PLAIN M 4.37	
9	153403002	2	ホルト4.37X7	BOLT, SM4.37X7	
10	S10065001	2	イチキメイタ	POSITIONING PLATE	
11	062680512	2	ナヘコ437-40X5	SCREW, PAN SM4.37-40X5	
			<エア-式用>	<For Pneumatic type>	
73	S42801101	2	オサエアシSE	WORK CLAMP, SE	
75	S42787001	2	オサエアシオサエイタA	WORK CLAMP GUIDE BRACKET, A	
76	S42884001	1	オサエアシオサエイタB	WORK CLAMP GUIDE PLATE, B	
82	062670712	2	ナヘコ357-40X7	SCREW, PAN SM3.57-40X7	
83	062671212	4	ナヘコ357-40X12	SCREW, PAN SM3.57-40X12	
84	107038003	4	サラネジ3.57	SCREW, FLAT SM3.57	
85	S43677001	1	オサエアシウケイタ	WORK CLAMP SUPPORT PLATE	
			<電磁式用>	<For Solenoid type>	
205	S43986201	1	オサエアシUN	WORK CLAMP, UN :SOL	
			<中厚物用>	<For Medium-weight materials>	
140	S55162001	1	オクリイタ311A	FEED PLATE, 311 A	
			<厚物用、極厚物用>	<For Heavy-weight materials & extra heavy-weight materials>	
140	S55163001	1	オクリイタ311B	FEED PLATE, 311 B	
			"オプション部品"	"OPTION PARTS"	
77	S42798001	1	オサエアシオサエイタ	WORK CLAMP GUIDE BRACKET	
78	S42799001	2	オサエチヨウセツイタ	WORK CLAMP ADJUSTING PLATE	
79	S42800001	2	オサエスキマチヨウセツイタ	ADJUSTING PLATE	
80	S42802101	2	オサエアシSE-OP	WORK CLAMP, SE-OP	
81	062670512	4	ナヘコ357-40X5	SCREW, PAN SM3.57-40X5	
139	S49955101	2	オクリイタシメネジ	SCREW, W/SOCKET SM4.37	
206	S43987001	1	311オサEUN	WORK CLAMP, 311 UN	
			<電磁式用>	<For Solenoid type>	
207	S47224001	1	オサエウテレバ-ハネUN	SPRING, UN	
			<ゲージ部品>	<Gauge parts>	
138	S42888001	1	ゲンテンギシユニタクミ	H-POSITION STANDARD PLATE ASSY	※

BAS-311F-0-202

☆RM欄に※が付いている部品は、精密な組み立て調整がして有りますので絶対に分解しないで下さい。

☆Parts which have an asterisk(※)in the RM column are parts which have been assembled and adjusted to high precisions.

These parts should never be disassembled.

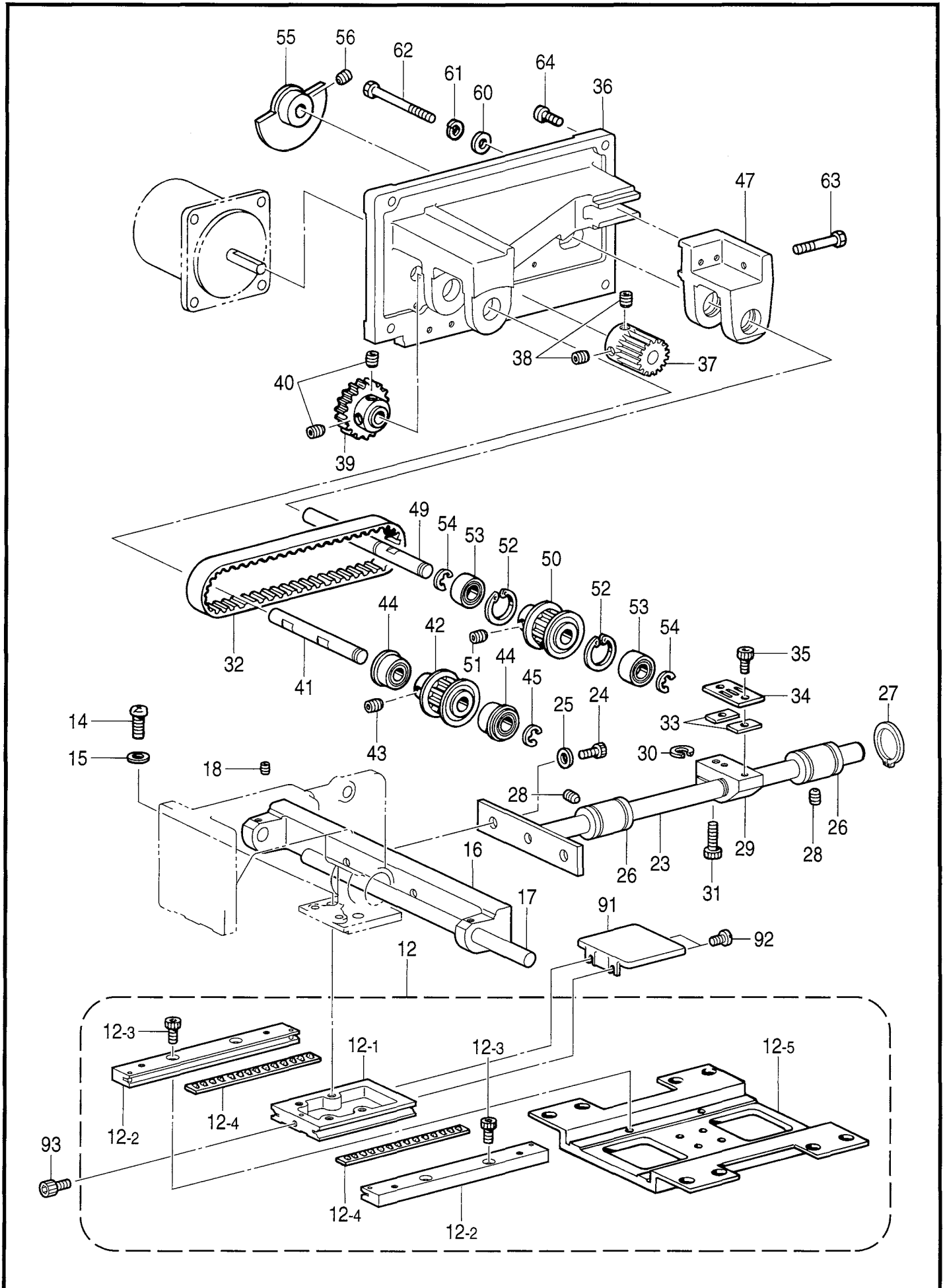

C2.送り関係 (311F-0) / Feed mechanism (311F-0)

REF.NO	CODE	Q'TY	品名	NAME OF PARTS	RM
12	S42774301	1	V11オクリダイクミ	Y-FEED BASE ASSY, V11	
12-1	S42816201	1	Yオクリダイ	Y-FEED BRACKET	
12-2	S10069301	2	Yオクリアンナイクミ	Y-FEED GUIDE ASSY	
12-3	S59890001	4	アナホルト437-40X8	BOLT, SOCKET SM4.37-40X8	
12-4	S42778000	2	クロスローラ	CROSS ROLLER	
12-5	S42779001	1	オクリダイX	FEED BAR, X	
14	062761412	2	ナベコ595-28X14	SCREW, PAN SM5.95-28X14	
15	025060132	2	ヒラサガネシヨウ6	WASHER, PLAIN S 6	
16	S55138001	1	311Xオクリシクササエ	X-FEED SHAFT SUPPORT, 311	
17	S55204001	1	311Xオクリシク	X-FEED SHAFT, 311	
18	152718001	2	アナムネジ5.95	SET SCREW, SOCKET SM5.95X5	
23	S55167001	1	Yクトウシク	Y-FEED SHAFT	
24	018501032	2	アナホルト5X10	BOLT, SOCKET M5X10	
25	025050232	2	ヒラサガネチユウ5	WASHER, PLAIN M 5	
26	S35183000	2	リニアブッシュ12	LINEAR BUSH, 12	
27	048200142	1	トメワシクヨウC20	RETAINING RING, EXTERNAL C20	
28	014760632	2	アナクホミ595-28X6	SET SCREW, SOCKET SM5.95-28X6	
29	S55211000	1	Yクトウシクホルダ	Y-DRIVING SHAFT HOLDER	
30	148782001	1	スペーサ	SPACER	
31	018501632	1	アナホルト5X16	BOLT, SOCKET M5X16	
32	S10077100	1	Yタイミングベルト	Y-TIMING BELT	
33	S10078001	2	Tベルトスペーサ	T-BELT SPACER	
34	S10079101	1	ベルトホルダ	BELT HOLDER	
35	S59890001	2	アナホルト437-40X8	BOLT, SOCKET SM4.37-40X8	
36	S55210001	1	YクトウPモータベース	Y-DRIVING P-MOTOR BASE	
37	S50673000	1	クトウギヤ20	DRIVING GEAR, 20	
38	014760632	2	アナクホミ595-28X6	SET SCREW, SOCKET SM5.95-28X6	
39	S42784100	1	アイドルギヤ32	IDLER GEAR, 32	
40	014760632	2	アナクホミ595-28X6	SET SCREW, SOCKET SM5.95-28X6	
41	S55203001	1	YプーリシクA	Y-PULLEY SHAFT, A	
42	S27844201	1	タイミングプーリア	TIMING PULLEY, A	
43	014770632	2	アナクホミ635-40X6	SET SCREW, SOCKET(CP) SM6.35X6	
44	070688850	2	タマシクウケ688ZZNR	BALL BEARING, 688ZZNR	
45	048060342	1	トメワE6	RETAINING RING, E6	
47	S35722200	1	YクトウPモータブラケット	Y-DRIVING P-MOTOR BRACKET	
49	S55205001	1	YプーリシクB	Y-PULLEY SHAAFT, B	
50	S27844201	1	タイミングプーリア	TIMING PULLEY, A	
51	014770632	2	アナクホミ635-40X6	SET SCREW, SOCKET(CP) SM6.35X6	
52	048160242	2	トメワアナヨウC16	RETAINING RING, INTERNAL C16	
53	530138001	2	マイクロベアリング8	BALL BEARING, MICRO 8	
54	048060342	2	トメワE6	RETAINING RING, E6	
55	S42785001	1	Yケンテントク	HOME POSITION DOG, Y	
56	014760632	1	アナクホミ595-28X6	SET SCREW, SOCKET SM5.95-28X6	
60	025050236	2	ヒラサガネチユウ5	WASHER, PLAIN M 5	
61	028050246	2	ハネサガネ2-5	WASHER, SPRING 2-5	
62	S25634101	2	アナホルト5X65	BOLT, SOCKET M5X65	
63	018503032	1	アナホルト5X30	BOLT, SOCKET M5X30	
64	062711212	4	ナベコ476-32X12	SCREW, PAN SM4.76-32X12	
91	S10140109	1	YオクリダイカバーA	Y-AXIS FEED BRACKET COVER, A	
92	106629002	2	シメネジ4.37	SCREW, SM4.37	
93	S59890001	1	アナホルト437-40X8	BOLT, SOCKET SM4.37-40X8	

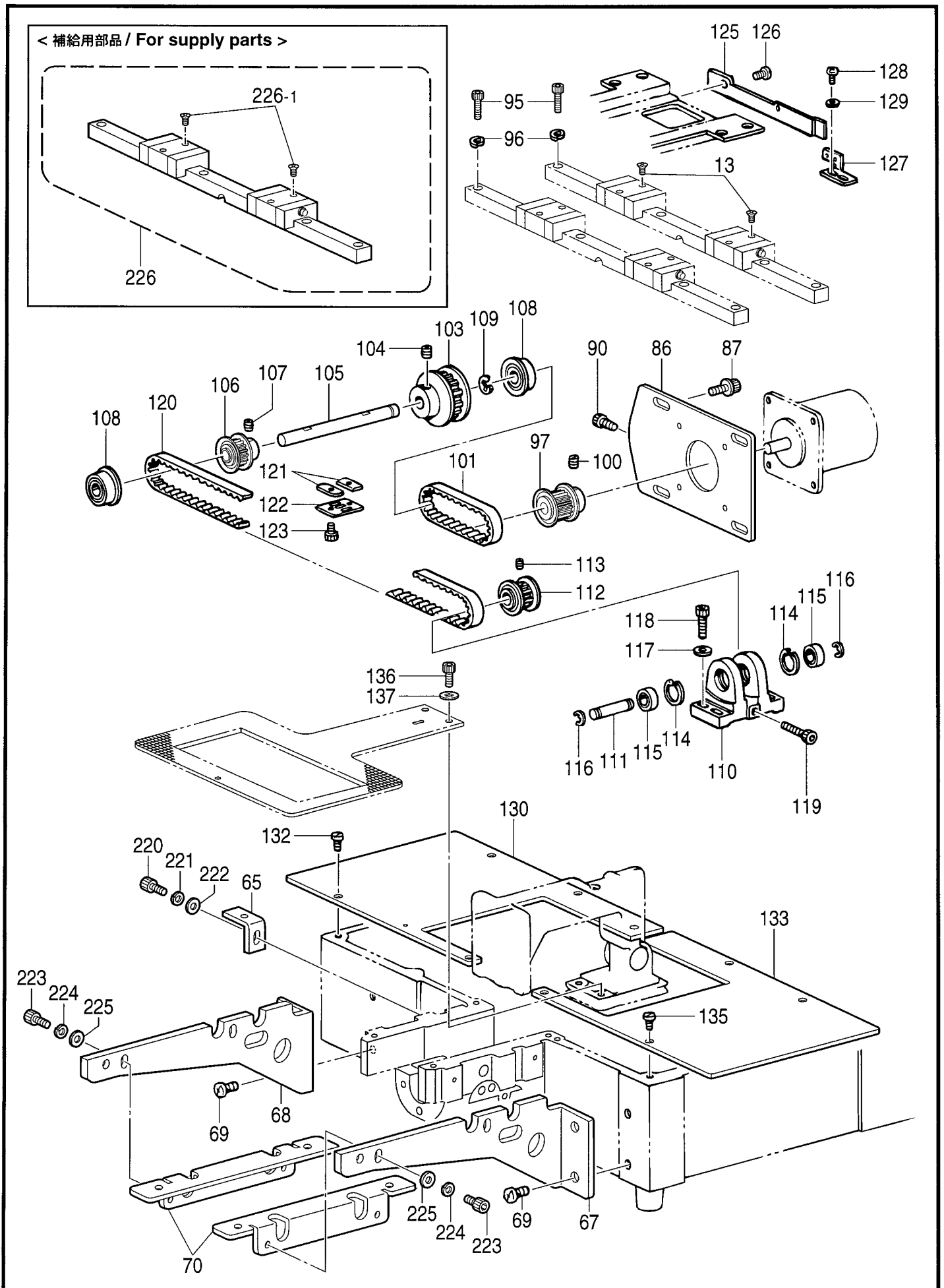

C3.送り関係 (311F-0) / Feed mechanism (311F-0)

REF.NO	CODE	Q'TY	品名	NAME OF PARTS	RM
13	S59637001	8	+サラコ4X8	SCREW, FLAT M4X8	
65	S10091201	4	ハリイタホシヨイタササエ	AUXILIARY PLATE SUPPORT	
67	S55142001	1	ホシヨイタササエRD	AUXILIARY PLATE SUPPORT, RD	
68	S55141001	1	ホシヨイタササエLD	AUXILIARY PLATE SUPPORT, LD	
69	062761012	4	ナヘコ595-28X10	SCREW, PAN SM5.95-28X10	
70	S55143001	2	ホシヨイタササエU	AUXILIARY PLATE SUPPORT, U	
86	S42817101	1	Xハルスモーターリツケイタ	X-PULSE MOTOR SETTING PLATE	
87	S55485002	4	アナホルトサクミ5X12	BOLT, SOCKET (S/P WASHER)M5X12	
90	018501432	1	アナホルト5X14	BOLT, SOCKET M5X14	
95	018401436	11	アナホルト4X14	BOLT, SOCKET M4X14	
96	028040246	11	ハネサガネ2-4	WASHER, SPRING 2-4	
97	S44382201	1	Xタイミングプーリア326	X-TIMING PULLEY, A326	
100	014770632	2	アナクホミ635-40X6	SET SCREW, SOCKET(CP) SM6.35X6	
101	S42790000	1	XタイミングベルトA311	X-TIMING BELT, A 311	
103	S42791101	1	XタイミングプーリアB311	X-TIMING PULLEY, B311	
104	014770632	2	アナクホミ635-40X6	SET SCREW, SOCKET(CP) SM6.35X6	
105	S42792001	1	Xタイミングプーリアジク	X-TIMING PULLEY SHAFT	
106	S27844201	1	タイミングプーリア	TIMING PULLEY, A	
107	014770632	2	アナクホミ635-40X6	SET SCREW, SOCKET(CP) SM6.35X6	
108	070688850	2	タマシクウケ688ZZNR	BALL BEARING, 688ZZNR	
109	048060342	1	トメワE6	RETAINING RING, E6	
110	S10133000	1	XプーリアB	X-PULLEY BASE, B	
111	S10134001	1	Xプーリアシャフト	X-PULLEY SHAFT, B	
112	S10087101	1	タイミングプーリアB	TIMING PULLEY, B	
113	014400532	2	アナクホミ4X5	SET SCREW, SOCKET (CP) M4X5	
114	048160242	2	トメワアナヨウC16	RETAINING RING, INTERNAL C16	
115	530138001	2	マイクロベアリング8	BALL BEARING, MICRO 8	
116	048060342	2	トメワE6	RETAINING RING, E6	
117	025050232	4	ヒラサガネチユウ5	WASHER, PLAIN M 5	
118	018501632	4	アナホルト5X16	BOLT, SOCKET M5X16	
119	018502532	1	アナホルト5X25	BOLT, SOCKET M5X25	
120	S42793000	1	XタイミングベルトB311	X-TIMING BELT, B 311	
121	S10078001	2	Tベルトスパーサ	T-BELT SPACER	
122	S10079101	1	ベルトホルダー	BELT HOLDER	
123	S59890001	2	アナホルト437-40X8	BOLT, SOCKET SM4.37-40X8	
125	S42795101	1	Xケンテントク	HOME POSITION DOG, X	
126	S44924001	2	シメネジM3X5.5	SCREW, M3X5.5	
127	S42796001	1	Xセンサートリツケイタ	X-SENSOR SETTING PLATE	
128	062400812	2	ナヘコ4X8	SCREW, PAN M4X8	
129	025040232	2	ヒラサガネチユウ4	WASHER, PLAIN M 4	
130	S42775101	1	XYオクリダイヤカバー-L	X-Y FEED BRACKET COVER, L	
132	106629002	4	シメネジ4.37	SCREW, SM4.37	
133	S42776101	1	XYオクリダイヤカバー-R	X-Y FEED BRACKET COVER, R	
135	106629002	4	シメネジ4.37	SCREW, SM4.37	
136	S59890001	2	アナホルト437-40X8	BOLT, SOCKET SM4.37-40X8	
137	025680232	2	ヒラサガネチユウ4.37	WASHER, PLAIN M 4.37	
220	S59893001	4	アナホルト437-40X10	BOLT, SOCKET SM4.37-40X10	
221	028680242	4	ハネサガネ2-4.37	WASHER, SPRING 2-4.37	
222	148847001	4	サガネ	WASHER, PLAIN 4.76	
223	S59893001	4	アナホルト437-40X10	BOLT, SOCKET SM4.37-40X10	
224	028680242	4	ハネサガネ2-4.37	WASHER, SPRING 2-4.37	
225	148847001	4	サガネ	WASHER, PLAIN 4.76	
226	S59741000	1	<補給用部品> リニアガイド311セット	<For supply parts> LENEAR GUIDE SET, 311	
226-1	S59637001	4	+サラコ4X8	SCREW, FLAT M4X8	

C4. 送り関係 (311F-0, 311F-L用オプション部品) /
 Feed mechanism (Option parts of 311F-0, 311F-L)

	M-508K	M-520K	M-525K	M-533K	M-528K
ホック寸法 Hook size (mm)					
スナップ寸法 Snap size (mm)	OM $\phi 7.6, \phi 8.6$ 				

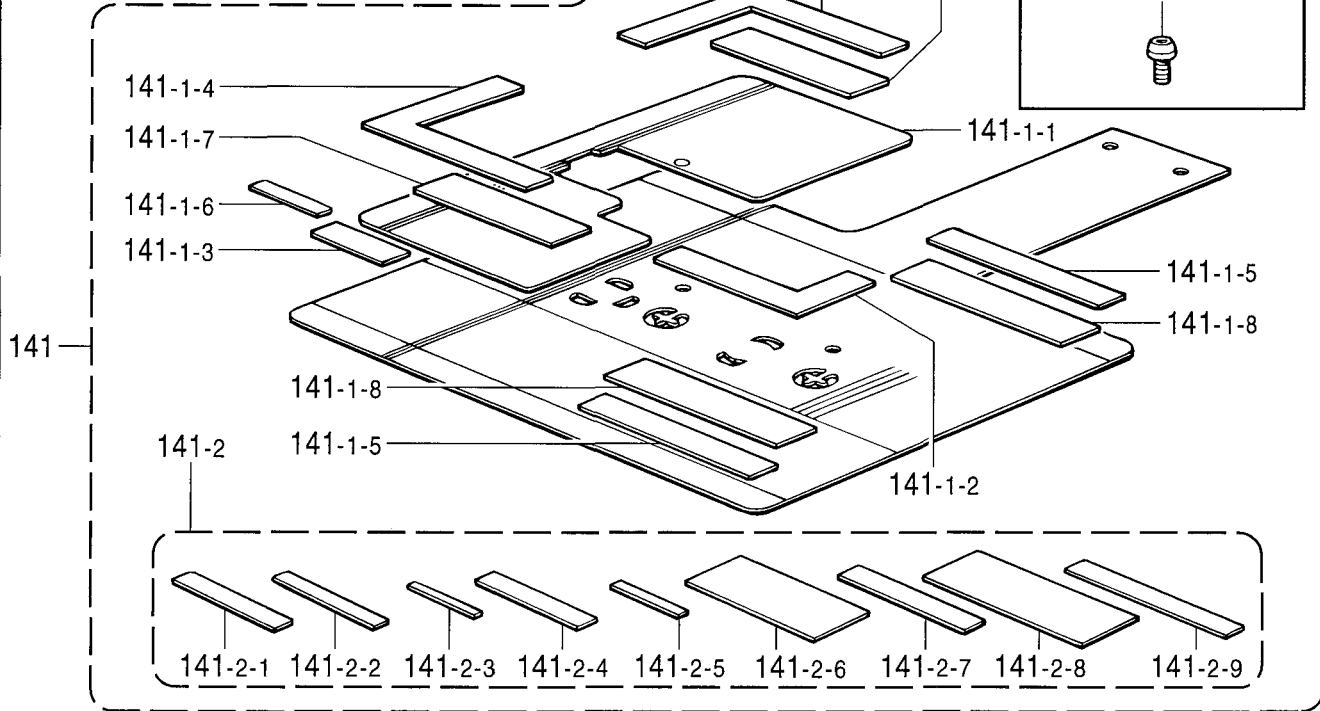
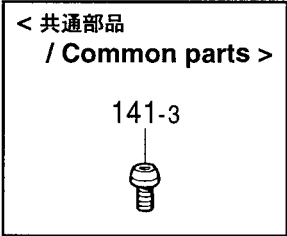
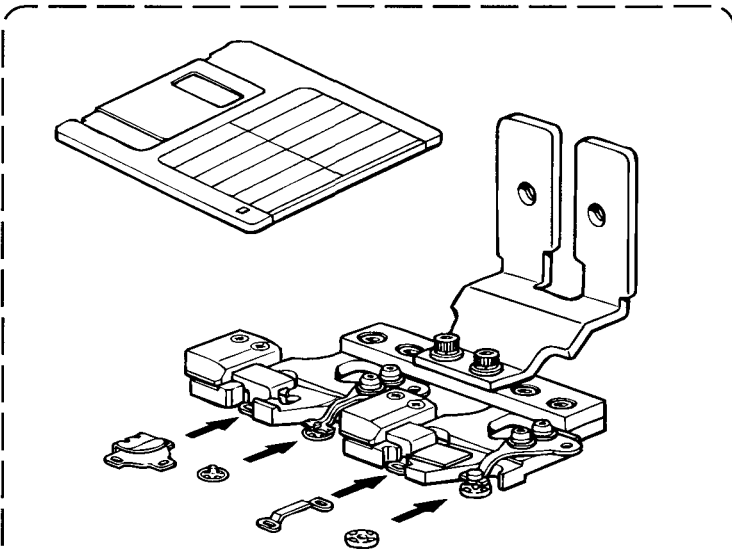
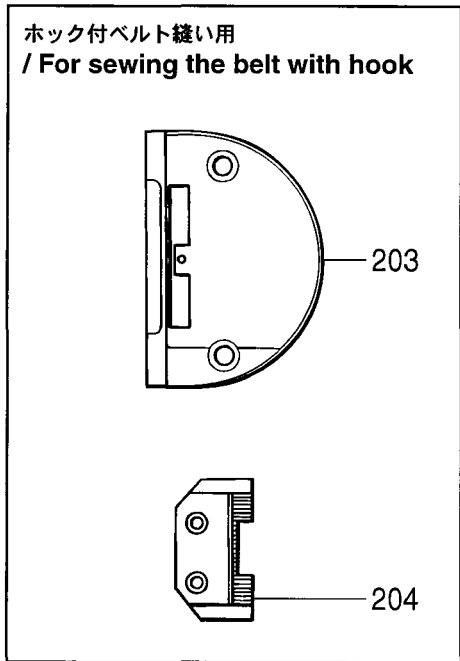

C4.送り関係 (311F-0, 311F-L用オプション部品) /
Feed mechanism (Option parts of 311F-0 & 311F-L)

REF.NO	CODE	Q'TY	品名	NAME OF PARTS	RM
			”スナップ、ホック付用” <M508K用>	”For Attaching the snap & hook” <For ”M508K”>	
141	S42803001	1	311-S.Hソウチソウクミ	311-S.H DEVICE SET	※
			<M528K用>	<For ”M528K”>	
141	S42806001	1	311-S.Hソウチソウクミ	311-S.H DEVICE SET	※
			<M520K用>	<For ”M520K”>	
141	S42808001	1	311-S.Hソウチソウクミ	311-S.H DEVICE SET	※
			<M525K用>	<For ”M525K”>	
141	S42810001	1	311-S.Hソウチソウクミ	311-S.H DEVICE SET	※
			<M533K用>	<For ”M533K”>	
141	S42812001	1	311-S.Hソウチソウクミ	311-S.H DEVICE SET	※
141-1-1	S10445000	1	ホキヨウシンガイド	CORE GUIDE	
141-1-2	S10446000	1	シタマエゲージA	LOWER FRONT GAUGE, A	
141-1-3	S10450000	1	シタマエホジヨケージA	LOWER FRONT SUB GAUGE, A	
141-1-4	S10454000	2	ウワマエゲージA	UPPER FRONT GAUGE, A	
141-1-5	S10458000	2	ウワマエホジヨケージA	UPPER FRONT SUB GAUGE, A	
141-1-6	S10452000	1	シタマエホジヨケージC	LOWER FRONT SUB GAUGE, C	
141-1-7	S10456000	2	ウワマエゲージC	UPPER FRONT GAUGE, C	
141-1-8	S10460000	2	ウワマエホジヨケージC	UPPER FRONT SUB GAUGE, C	
141-2	S13807000	1	ゲージS.Hクミ	GAUGE ASSY, S.H	
141-2-1	S10447000	1	シタマエゲージB	LOWER FRONT GAUGE, B	
141-2-2	S10448000	1	シタマエゲージC	LOWER FRONT GAUGE, C	
141-2-3	S10449000	1	シタマエゲージD	LOWER FRONT GAUGE, D	
141-2-4	S10451000	1	シタマエホジヨケージB	LOWER FRONT SUB GAUGE, B	
141-2-5	S10453000	1	シタマエホジヨケージD	LOWER FRONT SUB GAUGE, D	
141-2-6	S10455000	1	ウワマエゲージB	UPPER FRONT GAUGE, B	
141-2-7	S10457000	1	ウワマエゲージD	UPPER FRONT GAUGE, D	
141-2-8	S10459000	1	ウワマエホジヨケージB	UPPER FRONT SUB GAUGE, B	
141-2-9	S10461000	1	ウワマエホジヨケージD	UPPER FRONT SUB GAUGE, D	
			<共通部品>	<Common parts>	
141-3	153057102	2	オクリイタシメネジ	SCREW, ROUND W/SOCKET SM4.37	
			<ホック付ベルト縫い用>	<For Sewing the belt with hook>	
203	S13099001	1	ハリイタH	NEEDLE PLATE, H	
204	S13100001	1	オクリハH	FEED DOG, H	

BAS-311F-0-202

☆RM欄に※が付いている部品は、精密な組み立て調整がして有りますので絶対に分解しないで下さい。

☆Parts which have an asterisk(※)in the RM column are parts which have been assembled and adjusted to high precisions.

These parts should never be disassembled.

C5 . 送り関係 (311F-0, 311F-L, 326F-0用オプション部品) /
 Feed mechanism (Option parts of 311F-0, 311F-L, 326F-0)

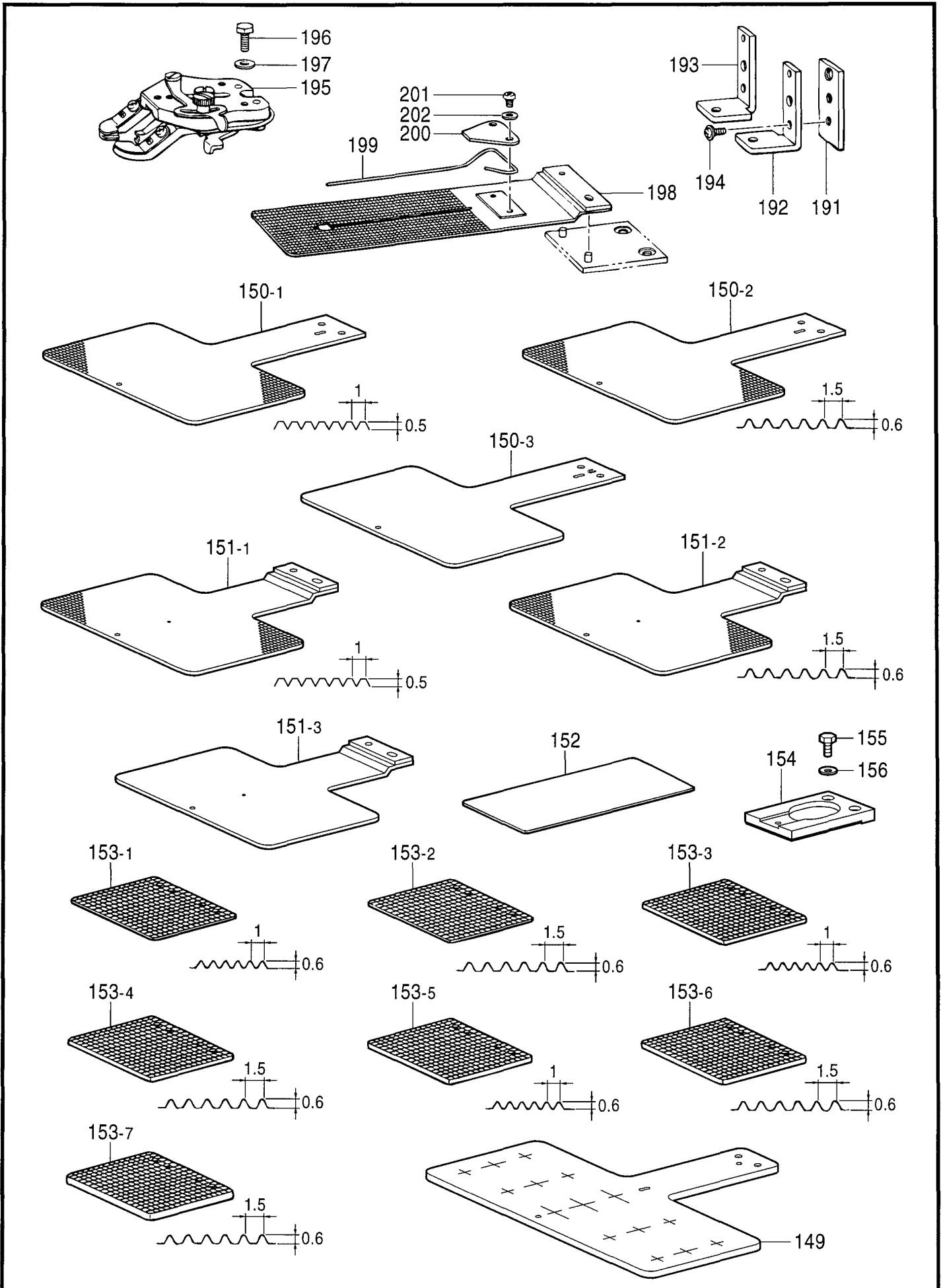

C5.送り関係 (311F-0, 311F-L, 326F-0用オプション部品) /

Feed mechanism (Option parts of 311F-0, 311F-L & 326F-0)

REF.NO	CODE	Q'TY	品名	NAME OF PARTS	RM
149	S55161001	1	<311F-0, 311F-L用 ゲージ部品> ケンテンギシユンイタ311	<For 311F-0 & 311F-L Gauge parts> H-POSITION STANDARD PLATE, 311	
150-1	S55164001	1	<311F-0 送り板用アタッチメント> オクリイタ311Aブランク	<For Feed plate attachment of 311F-0> FEED PLATE BLANK, A 311	
150-2	S55165001	1	オクリイタ311Bブランク	FEED PLATE BLANK, B 311	
150-3	S55166001	1	オクリイタ311Cブランク	FEED PLATE BLANK, C 311	
151-1	S43700001	1	<311F-0 ワンタッチ押え用> OTオクリイタAブランク	<For One-touch work clamp of 311F-0> OT-FEED PLATE BLANK, A	
151-2	S43821001	1	OTオクリイタBブランク	OT-FEED PLATE BLANK, B	
151-3	S43822001	1	OTオクリイタCブランク	OT-FEED PLATE BLANK, C	
152	S43823000	1	<311F-0 送り板用アタッチメント> オクリイタインナープレート	<For Feed plate attachment of 311F-0> INNER PLATE, FEED PLATE	
154	S51804001	1	<311F-0, 311F-L, 326F-0 送り板用アタッチメント> オクリイタ外リツケダイ	<For Feed plate attachment of 311F-0, 311F-L & 326F-0> FEED PLATE SETTING BASE	
155	153403002	1	ホルト4.37X7	BOLT, SM4.37X7	
156	025680232	1	ヒラサガネチユウ4.37	WASHER, PLAIN M 4.37	
153-1	S43824001	1	“311F-0押え用ブランク材” <板厚3.2mm> オサエブランクA-3.2	“The Blank for work clamp of 311F-0” <Thick = 3.2mm> WORK CLAMP BLANK, A-3.2	
153-2	S43825001	1	オサエブランクB-3.2	WORK CLAMP BLANK, B-3.2	
153-3	S43826001	1	<板厚4.0mm> オサエブランクA-4.0	<Thick = 4.0mm> WORK CLAMP BLANK, A-4.0	
153-4	S43827001	1	オサエブランクB-4.0	WORK CLAMP BLANK, B-4.0	
153-5	S43828001	1	<板厚5.0mm> オサエブランクA-5.0	<Thick = 5.0mm> WORK CLAMP BLANK, A-5.0	
153-6	S43829001	1	オサエブランクB-5.0	WORK CLAMP BLANK, B-5.0	
153-7	S43830001	1	<板厚6.0mm> オサエブランク-6.0	<Thick = 6.0mm> WORK CLAMP BLANK, 6.0	
191	S31365001	2	<311F-0, 311F-L, 326F-0 ボタン付用> ボタンツカミホルダー	<For Attaching the button 311F-0, 311F-L & 326F-0> BUTTON CLAMP HOLDER	
192	S14848001	1	BUオサエアシU-R	BU WORK CLAMP, U-R	
193	S14849001	1	BUオサエアシU-L	BU WORK CLAMP, U-L	
194	149168001	2	ザツキシメネジ4.37	SCREW, W/FLANGE SM4.37	
195	S30015101	1	ボタンツカミ	BUTTON CLAMP ASSY	
196	117363001	2	ホルト4.76	BOLT, SM4.76	
197	025710232	2	ヒラサガネチユウ4.76	WASHER, PLAIN M 4.76	
198	S14069001	1	OTオクリイタ7ヒラ	OT-FEED PLATE 7 PLAIN	
199	153871001	1	ボタンウカシバネ1.2	SPRING, 1.2	
200	S14073001	1	ウカシバネオサエイタ	SPRING	
201	062670512	2	ナベコ357-40X5	SCREW, PAN SM3.57-40X5	
202	102707002	2	サガネ	WASHER	

C6 . 送り関係 (311F-0, 311F-L, 326F-0用オプション部品) /
 Feed mechanism (Option parts of 311F-0, 311F-L, 326F-0)

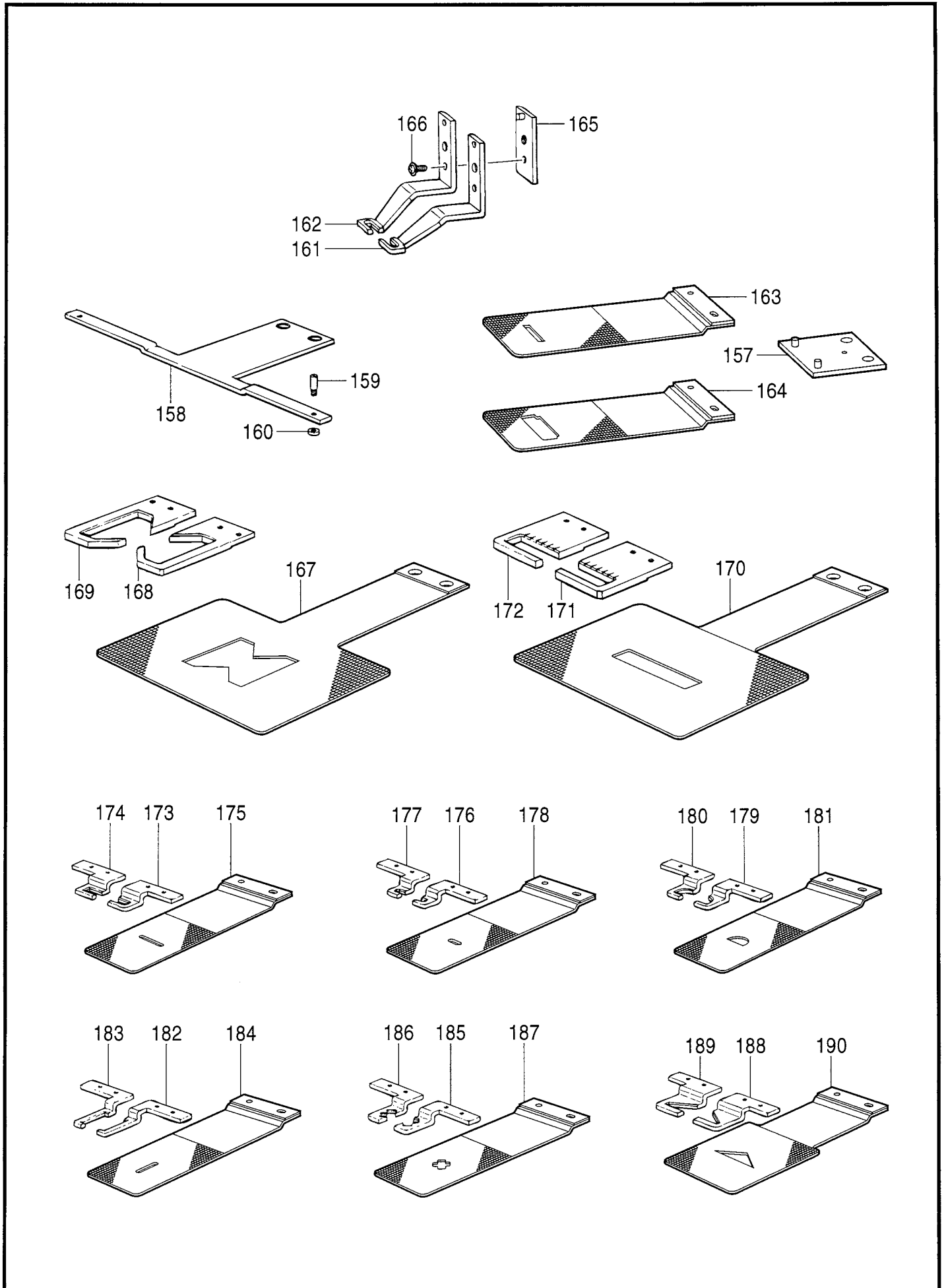

C6.送り関係 (311F-0, 311F-L, 326F-0用オプション部品) /

Feed mechanism (Option parts of 311F-0, 311F-L & 326F-0)

REF.NO	CODE	Q'TY	品名	NAME OF PARTS	RM
157	S57952001	1	<ワンタッチ押え用> OTオクリイタダイクミ	<For One-touch work clamp> OT-FEED PLATE BRACKET ASSY	
158	S13006101	1	カセットシジイタ	CASSETTE HOLDER PLATE	
159	S13007001	2	カセットシジピン	CASSETTE HOLDER PIN	
160	021660306	2	3シュナツト318-40	NUT, 3 SM3.18-40	
161	S14254001	1	<門止縫い 61.5X86.5用> オサエアシSR	<For Sewing the bar tack"61.5X86.5"> WORK CLAMP, SR	
162	S14255001	1	オサエアシSL	WORK CLAMP, SL	
165	S14846001	2	OTオサエアシDクミ	OT-WORK CLAMP ASSY, D	
166	149168001	2	ザツキシメネジ4.37	SCREW, W/FLANGE SM4.37	
163	S14253001	1	<デニム用> OTオクリイタDE	<For Denim> OT-FEED PLATE BLANK, DE	
164	S14252001	1	<一般用> OTオクリイタST	<For General> OT-FEED PLATE	
167	S13092001	1	<ベンツしつけ縫い用> オクリイタ310-2	<For Besting the vent> FEED PLATE, 310-002	
168	S13090001	1	オサエR310-002	WORK CLAMP, R 310-002	
169	S13091001	1	オサエL310-002	WORK CLAMP, L 310-002	
170	S13098001	1	<フラン止め縫い用> オクリイタ310-3	<For Attacching the thread loop> FEED PLATE, 310-003	
171	S13096001	1	オサエR310-003	WORK CLAMP, R 310-003	
172	S13097001	1	オサエL310-003	WORK CLAMP, L 310-003	
173	S23818001	1	<門止縫い 23X6用> オサエR311-004	<For Sewing the bar tack"23X6"> WORK CLAMP, R 311-004	
174	S23819001	1	オサエL311-004	WORK CLAMP, L 311-004	
175	S23820001	1	オクリイタ311-004	FEED PLATE, 311-004	
176	S23821001	1	<門止縫い 10.4X4.4用> オサエR311-005	<For Sewing the bar tack"10.4X4.4"> WORK CLAMP, R 311-005	
177	S23822001	1	オサエL311-005	WORK CLAMP, L 311-005	
178	S23823001	1	オクリイタ311-005	FEED PLATE, 311-005	
179	S23824001	1	<半月門止縫い用> オサエR311-006	<For Sewing the bar tack"half-circle"> WORK CLAMP, R 311-006	
180	S23825001	1	オサエL311-006	WORK CLAMP, L 311-006	
181	S23826001	1	オクリイタ311-006	FEED PLATE, 311-006	
182	S23827001	1	<門止縫い 6X23用> オサエR311-007	<For Sewing the bar tack"6X23"> WORK CLAMP, R 311-007	
183	S23828001	1	オサエL311-007	WORK CLAMP, L 311-007	
184	S23829001	1	オクリイタ311-007	FEED PLATE, 311-007	
185	S23830001	1	<X門止縫い用> オサエR311-008	<For Sewing the bar tack"x-cross"> WORK CLAMP, R 311-008	
186	S23831001	1	オサエL311-008	WORK CLAMP, L 311-008	
187	S23832001	1	オクリイタ311-008	FEED PLATE, 311-008	
188	S23833001	1	<三角門止縫い用> オサエR311-009	<For sewing the bar tack"triangle"> WORK CLAMP, R 311-009	
189	S23834001	1	オサエL311-009	WORK CLAMP, L 311-009	
190	S23835001	1	オクリイタ311-009	FEED PLATE, 311-009	

C7. 送り関係 (311F-0, 311F-L用オプション部品) /
 Feed mechanism (Option parts of 311F-0, 311F-L)

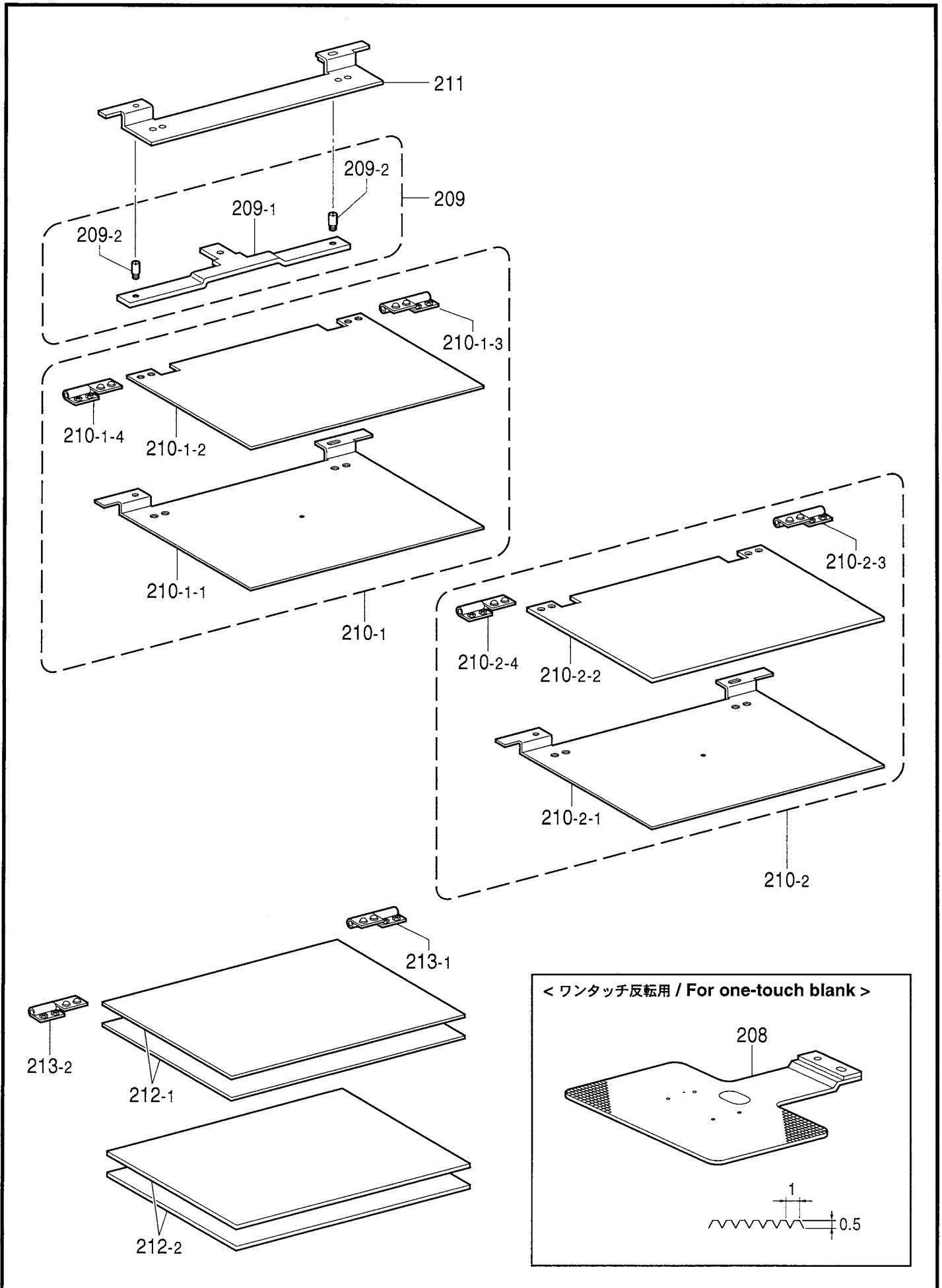

BAS-311F-0-202

C7.送り関係 (311F-0, 311F-L 用オプション部品) /
 Feed mechanism (Option parts of 311F-0, 311F-L)

REF.NO	CODE	Q'TY	品名	NAME OF PARTS	RM
208	S14598001	1	<ワンタッチ反転用> OTオクリイタブランク312	<For One-touch-blank> OT FEED PLATE BLANK, 312	
209	S02963201	1	カセットシジイタキ	CASSETTE HOLDER PLATE ASSY	
209-1	S33533101	1	カセットシジイタ	CASSETTE HOLDER PLATE	
209-2	S19629001	2	カセットシジピン	PIN, C-HOLDER	
210-1	S02959101	1	カセットオサエイクミ	CASSETTE PRESSER ASSY, A	
210-1-1	S02966101	1	カセットイタD-A	CASSETTE PLATE, D-A	
210-1-2	S02968000	1	カセットイタU-A	CASSETTE PLATE, U-A :T=1	
210-1-3	152632001	1	チヨウバンクミミキ	HINGE ASSY, R	
210-1-4	152633001	1	チヨウバンクミヒダリ	HINGE ASSY, L	
210-2	S02960101	1	カセットオサエイクミ	CASSETTE PRESSER ASSY, B	
210-2-1	S02966101	1	カセットイタD-A	CASSETTE PLATE, D-A	
210-2-2	S02971000	1	カセットイタU-B	CASSETTE PLATE, U-B :T=2	
210-2-3	152632001	1	チヨウバンクミミキ	HINGE ASSY, R	
210-2-4	152633001	1	チヨウバンクミヒダリ	HINGE ASSY, L	
			<樹脂板用>	<For Resin plate>	
211	S02967101	2	カセットイタD-B	CASSETTE PLATE, D-B	
212-1	S02969000	2	カセットシタイタ	CASSETTE LOWER PLATE, A :T=1	
212-2	S02970000	2	カセットシタイタB	CASSETTE LOWER PLATE, B :T=2	
213-1	152632001	2	チヨウバンクミミキ	HINGE ASSY, R	
213-2	152633001	2	チヨウバンクミヒダリ	HINGE ASSY, L	

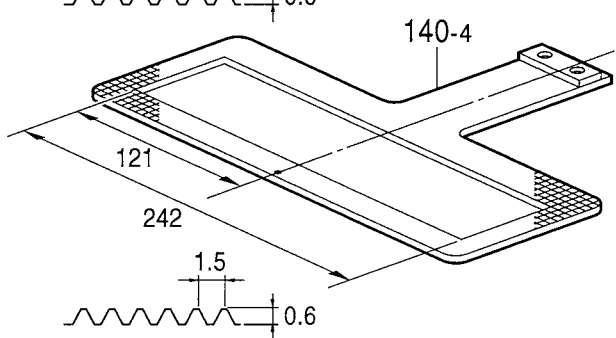
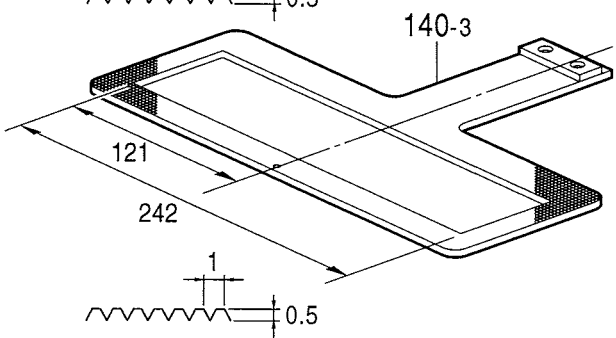
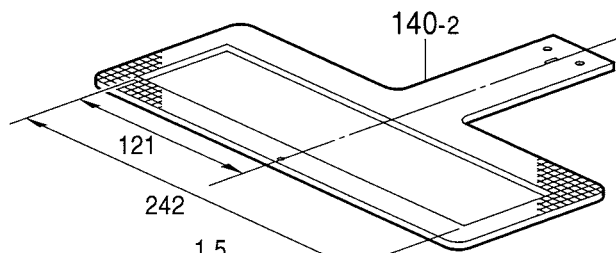
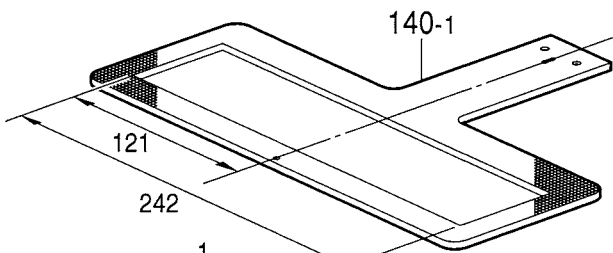
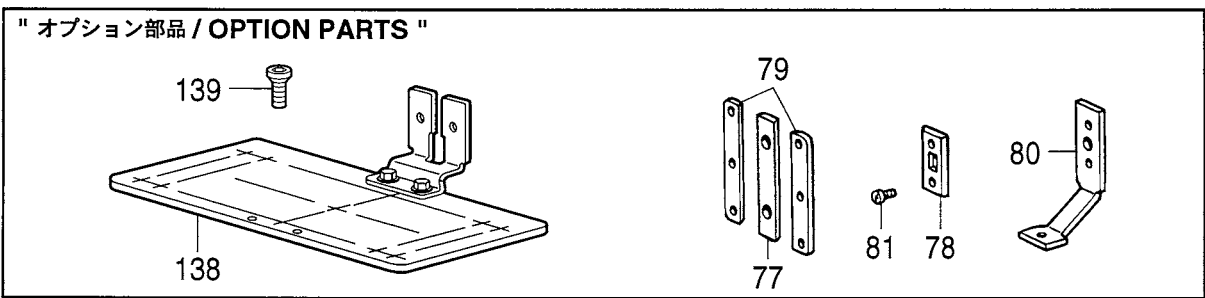
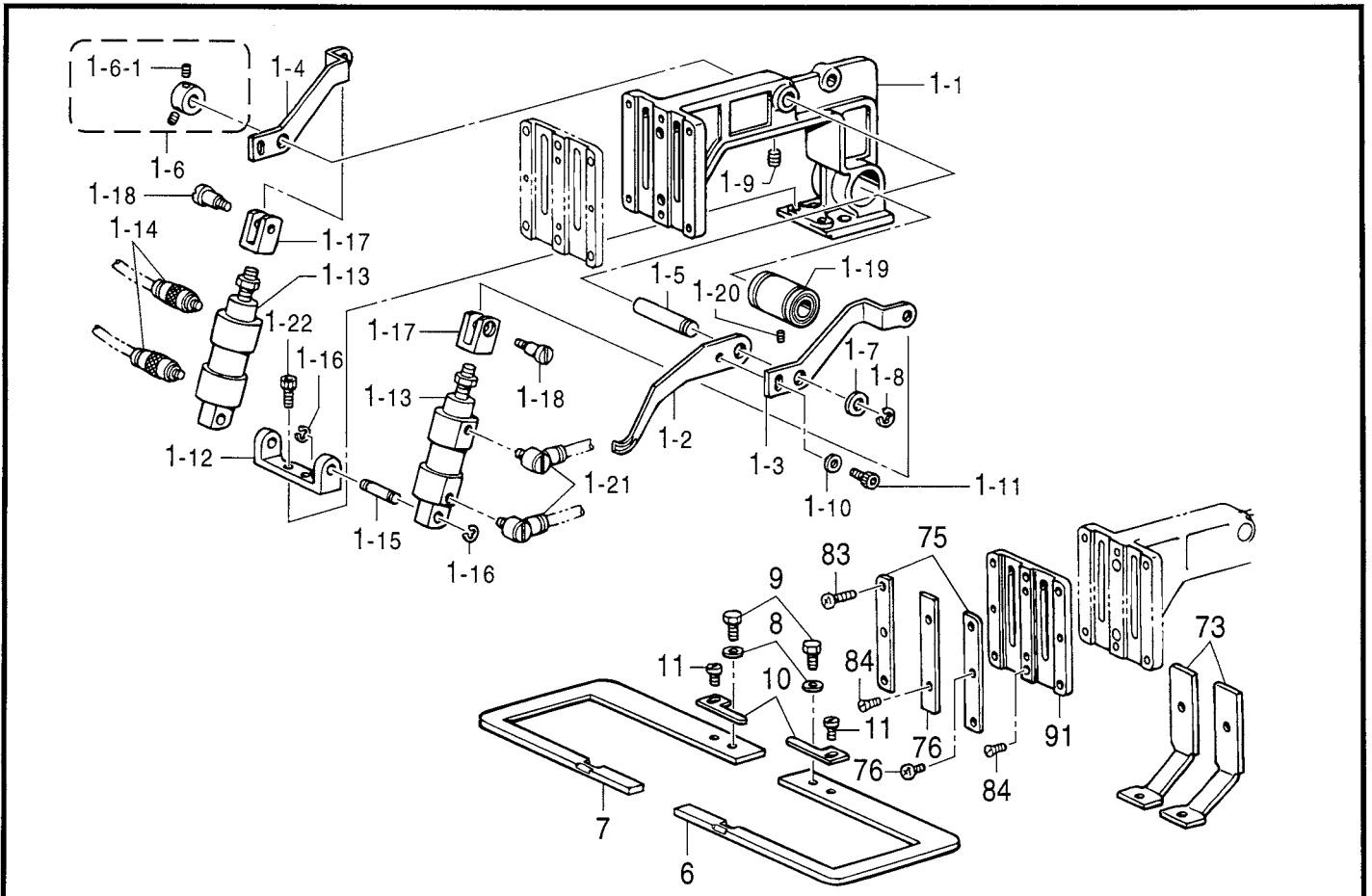

C8.送り関係 (311F-L) / Feed mechanism (311F-L)

REF.NO	CODE	Q'TY	品名	NAME OF PARTS	RM
1	S42768101	1	オサエウテ`クミAIR	WORK CLAMP ARM ASSY, AIR	
1-1	S42761000	1	オサエウテ`	WORK CLAMP ARM	
1-2	S42764001	2	オサエウテ`レバ`-F	WORK CLAMP ARM LEVER, F	
1-3	S42769001	1	オサエウテ`レバ`-RR-A	WORK CLAMP ARM LEVER, RR-A	
1-4	S42770001	1	オサエウテ`レバ`-RL-A	WORK CLAMP ARM LEVER, RL-A	
1-5	S10058001	1	オサエウテ`レバ`-ジク	W-CLAMP ARM LEVER SHAFT	
1-6	S21775001	1	セツトカラ`クミ	SET SCREW COLLAR ASSY	
1-6-1	014680432	2	アナクホ`ミ437-40X4	SET SCREW, SOCKET SM4.37-40X4	
1-7	143591001	1	スラストリング`	THRUST RING	
1-8	048050342	1	トメワE5	RETAINING RING, E5	
1-9	014760632	1	アナクホ`ミ595-28X6	SET SCREW, SOCKET SM5.95-28X6	
1-10	025040232	2	ヒラサ`ガ`ネチユウ4	WASHER, PLAIN M 4	
1-11	018400632	2	アナホ`ルト4X6	BOLT, SOCKET M4X6	
1-12	S10379001	1	シリンダ`ササエ	CYLINDER SUPPORT	
1-13	S42878000	2	エアシリンダ`15-18	AIR CYLINDER, 15-18	
1-14	S18415101	2	ハーフユニオンQ4M5	HALF UNION :Q4M5	
1-15	S03800001	2	クレビスピン`	CLEVIS PIN	
1-16	048040342	4	トメワE4	RETAINING RING, E4	
1-17	S03801101	2	シリンダ`ツキテ`	CYLINDER JOINT	
1-18	110168001	2	コロシク`	ROLLER SHAFT	
1-19	S12004000	1	リニアブ`ツシュ	LINEAR BUSH	
1-20	011679312	1	トメネジ`3.57ヒラ`	SET SCREW, (FT) SM3.57	
1-21	S41271000	2	エルホ`M5	ELBOW, M5	
1-22	018501232	2	アナホ`ルト5X12	BOLT, SOCKET M5X12	
6	S55931001	1	311LオサエR	WORK CLAMP, R :311L	
7	S55932001	1	311LオサエL	WORK CLAMP, L :311L	
8	025680232	2	ヒラサ`ガ`ネチユウ4.37	WASHER, PLAIN M 4.37	
9	153403002	2	ホ`ルト4.37X7	BOLT, SM4.37X7	
10	S10065001	2	イチキ`メイタ`	POSITIONING PLATE	
11	062680512	2	ナ`コ437-40X5	SCREW, PAN SM4.37-40X5	
73	S42801101	2	オサエアシ`SE	WORK CLAMP, SE	
75	S42787001	2	オサエアシ`オサエイタ`A	WORK CLAMP GUIDE BRACKET, A	
76	S42884001	1	オサエアシ`オサエイタ`B	WORK CLAMP GUIDE PLATE, B	
82	062670712	2	ナ`コ357-40X7	SCREW, PAN SM3.57-40X7	
83	062671212	4	ナ`コ357-40X12	SCREW, PAN SM3.57-40X12	
84	107038003	4	サラネジ`3.57	SCREW, FLAT SM3.57	
85	S43677001	1	オサエアシ`ウケイタ`	WORK CLAMP SUPPORT PLATE	
140-2	S55941001	1	<厚物用> オクリイタ`311LB	<For Heavy-weight materials> FEED PLATE, B :311L	
140-3	S57718001	1	“送り板皿タイプ” <厚物用> オクリイタ`311LA	“For plate of flat head” <For Heavy-weight materials> FEED PLATE, 311LA	
140-4	S57719001	1	<中厚物用> オクリイタ`311LB	<For Medium-weight materials> FEED PLATE, 311LB	
77	S42798001	1	オサエアシ`オサエイタ`	WORK CLAMP GUIDE BRACKET	
78	S42799001	2	オサエチヨウ`セツイタ`	WORK CLAMP ADJUSTING PLATE	
79	S42800001	2	オサエスキマ`チヨウ`セツイタ`	ADJUSTING PLATE	
80	S42802101	2	オサエアシ`SE-OP	WORK CLAMP, SE-OP	
81	062670512	4	ナ`コ357-40X5	SCREW, PAN SM3.57-40X5	
138	S44608101	1	ケンテンキジ`ユニイタ`クミ	H-POSITION STANDARD PLATE ASSY	※
139	S49955101	2	オクリイタ`シメネジ`	SCREW, W/SOCKET SM4.37	
140-1	S55940001	1	<中厚物用> オクリイタ`311LA	<For Medium-weight materials> FEED PLATE, A :311L	

BAS-311F-L-202

☆RM欄に※が付いている部品は、精密な組み立て調整がして有りますので絶対に分解しないで下さい。

☆Parts which have an asterisk(※)in the RM column are parts which have been assembled and adjusted to high precisions.

These parts should never be disassembled.

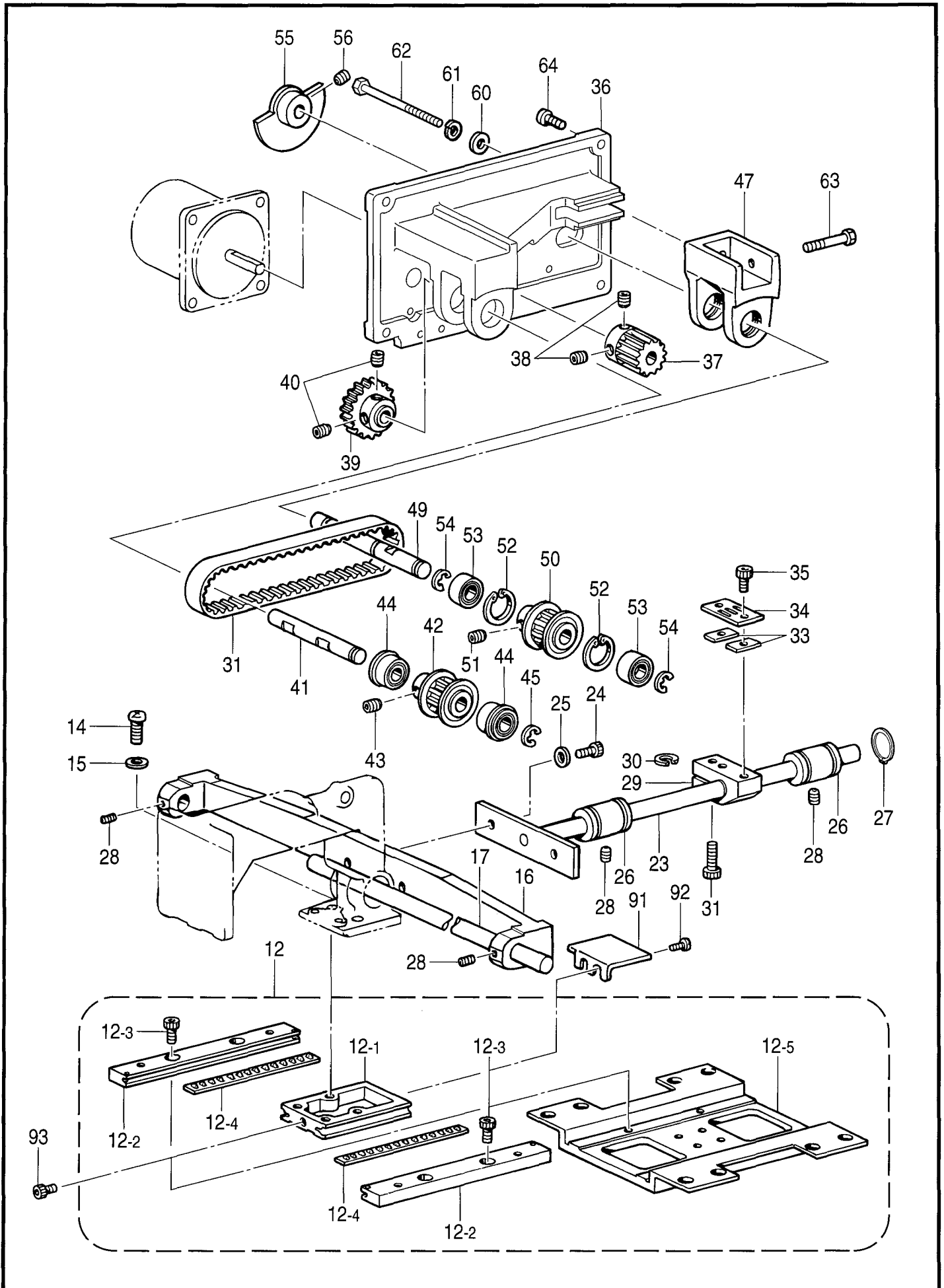

C9.送り関係 (311F-L) / Feed mechanism (311F-L)

REF.NO	CODE	Q'TY	品名	NAME OF PARTS	RM
12	S42774301	1	V11オクリダイクミ	Y-FEED BASE ASSY, V11	
12-1	S42816201	1	Yオクリダイ	Y-FEED BRACKET	
12-2	S10069301	2	Yオクリアンナイクミ	Y-FEED GUIDE ASSY	
12-3	S59890001	4	アナホルト437-40X8	BOLT, SOCKET SM4.37-40X8	
12-4	S42778000	2	クロスローラ	CROSS ROLLER	
12-5	S42779001	1	オクリダイX	FEED BAR, X	
14	062761412	2	ナベコ595-28X14	SCREW, PAN SM5.95-28X14	
15	025060132	2	ヒラサガネシヨウ6	WASHER, PLAIN S 6	
16	S55933100	1	311LXオクリシクササエ	FEED SHAFT SUPPORT, X:311L	
17	S44616001	1	311LXオクリシク	X-AXIS FEED SHAFT, 311L	
18	152718001	2	アナトメネジ5.95	SET SCREW, SOCKET SM5.95X5	
23	S55934101	1	Yクトウシク	Y-DRIVING SHAFT	
24	018501032	2	アナホルト5X10	BOLT, SOCKET M5X10	
25	025050232	2	ヒラサガネチユウ5	WASHER, PLAIN M 5	
26	S35183000	2	リニアブツシユ12	LINEAR BUSH, 12	
27	048200142	1	トメワシクヨウC20	RETAINING RING, EXTERNAL C20	
28	014760632	2	アナクホミ595-28X6	SET SCREW, SOCKET SM5.95-28X6	
29	S55211000	1	Yクトウシクホルダ	Y-DRIVING SHAFT HOLDER	
30	148782001	1	スベサ	SPACER	
31	018501632	1	アナホルト5X16	BOLT, SOCKET M5X16	
32	S10077100	1	Yタイミングベルト	Y-TIMING BELT	
33	S10078001	2	Tベルトスベサ	T-BELT SPACER	
34	S10079101	1	ベルトホルダ	BELT HOLDER	
35	S59890001	2	アナホルト437-40X8	BOLT, SOCKET SM4.37-40X8	
36	S55210001	1	YクトウPモータベース	Y-DRIVING P-MOTOR BASE	
37	S50673000	1	クトウキヤ20	DRIVING GEAR, 20	
38	014760632	2	アナクホミ595-28X6	SET SCREW, SOCKET SM5.95-28X6	
39	S42784100	1	アイドルキヤ32	IDLER GEAR, 32	
40	014760632	2	アナクホミ595-28X6	SET SCREW, SOCKET SM5.95-28X6	
41	S55203001	1	YプーリシクA	Y-PULLEY SHAFT, A	
42	S27844201	1	タイミングプーリア	TIMING PULLEY, A	
43	014770632	2	アナクホミ635-40X6	SET SCREW, SOCKET(CP) SM6.35X6	
44	070688850	2	タマシクウケ688ZZNR	BALL BEARING, 688ZZNR	
45	048060342	1	トメワE6	RETAINING RING, E6	
47	S35722200	1	YクトウPモータブラケット	Y-DRIVING P-MOTOR BRACKET	
49	S55205001	1	YプーリシクB	Y-PULLEY SHAAFT, B	
50	S27844201	1	タイミングプーリア	TIMING PULLEY, A	
51	014770632	2	アナクホミ635-40X6	SET SCREW, SOCKET(CP) SM6.35X6	
52	048160242	2	トメワアナヨウC16	RETAINING RING, INTERNAL C16	
53	530138001	2	マイクロベアリング8	BALL BEARING, MICRO 8	
54	048060342	2	トメワE6	RETAINING RING, E6	
55	S42785001	1	Yゲンテントク	HOME POSITION DOG, Y	
56	014760632	1	アナクホミ595-28X6	SET SCREW, SOCKET SM5.95-28X6	
60	025050236	2	ヒラサガネチユウ5	WASHER, PLAIN M 5	
61	028050246	2	ハネサガネ2-5	WASHER, SPRING 2-5	
62	S25634101	2	アナホルト5X65	BOLT, SOCKET M5X65	
63	018503032	1	アナホルト5X30	BOLT, SOCKET M5X30	
64	062711212	4	ナベコ476-32X12	SCREW, PAN SM4.76-32X12	
91	S10140109	1	YオクリダイカバーA	Y-AXIS FEED BRACKET COVER, A	
92	106629002	2	シメネジ4.37	SCREW, SM4.37	
93	S59890001	1	アナホルト437-40X8	BOLT, SOCKET SM4.37-40X8	

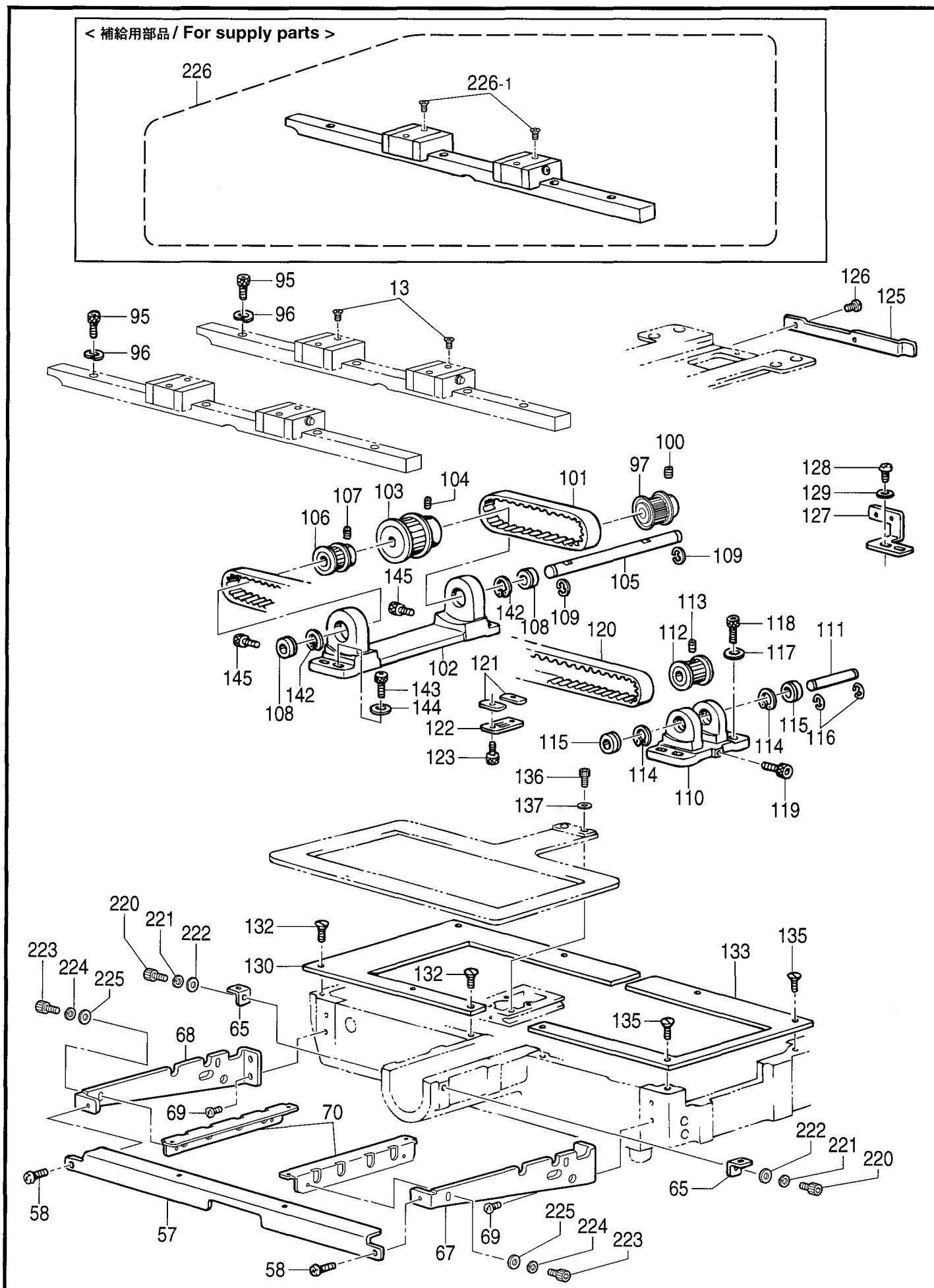

C10.送り関係 (311F-L) / Feed mechanism (311F-L)

REF.NO	CODE	QTY	品名	NAME OF PARTS	RM
13	S59637001	8	+サラコ4X8	SCREW, FLAT M4X8	
57	S44757101	1	ホシヨイタササEM	SUPPORT PLATE GUIDE, M	
58	060680712	2	バインド437-40X7	SCREW, BIND SM4.37-40X7	
65	S10091201	4	ハリイタホシヨイタササE	AUXILIARY PLATE SUPPORT	
67	S55935001	1	ホシヨイタササIRD	SUPPORT PLATE GUIDE, R :D	
68	S55936001	1	ホシヨイタササILD	SUPPORT PLATE GUIDE, L :D	
69	062761012	4	ナベコ595-28X10	SCREW, PAN SM5.95-28X10	
70	S55937001	2	ホシヨイタササIU	SUPPORT, U	
95	018401436	11	アナホルト4X14	BOLT, SOCKET M4X14	
96	028040246	11	ハネサガネ2-4	WASHER, SPRING 2-4	
97	S44382201	1	Xタイミングプーリア326	X-TIMING PULLEY, A326	
100	014770632	2	アナクホミ635-40X6	SET SCREW, SOCKET(CP) SM6.35X6	
101	S44456000	1	XタイミングベルトA326	X-TIMING BELT, A 326	
102	S44457000	1	Xプーリダイル	X-PULLEY BRACKET, L	
103	S44458101	1	XタイミングプーリB326	X-TIMING PULLEY, B326	
104	014770632	2	アナクホミ635-40X6	SET SCREW, SOCKET(CP) SM6.35X6	
105	S44459001	1	Xタイミングプーリジク	X-TIMING PULLEY SHAFT	
106	S17885101	1	タイミングプーリア	TIMING PULLEY, A	
107	014770632	2	アナクホミ635-40X6	SET SCREW, SOCKET(CP) SM6.35X6	
108	530138001	2	マイクロベアリング8	BALL BEARING, MICRO 8	
109	048060342	2	トメワE6	RETAINING RING, E6	
110	S17886100	1	Xプーリダイル	X-PULLEY BRACKET, R	
111	S17887001	1	XプーリジクR	X-PULLEY SHAFT, R	
112	S17888001	1	タイミングプーリB	TIMING PULLEY, B	
113	014710532	2	アナクホミ476-32X5	SET SCREW, SOCKET SM4.76-32X5	
114	048160242	2	トメワアナヨウC16	RETAINING RING, INTERNAL C16	
115	530138001	2	マイクロベアリング8	BALL BEARING, MICRO 8	
116	048060342	2	トメワE6	RETAINING RING, E6	
117	025050232	4	ヒラサガネチユウ5	WASHER, PLAIN M 5	
118	018501632	4	アナホルト5X16	BOLT, SOCKET M5X16	
119	018501632	1	アナホルト5X16	BOLT, SOCKET M5X16	
120	S44624000	1	Xタイミングベルト311L	X-TIMING BELT, B 311L	
121	S10078001	2	Tベルトスパーサ	T-BELT SPACER	
122	S47115001	1	Yベルトホルダ	Y-BELT HOLDER	
123	S59890001	2	アナホルト437-40X8	BOLT, SOCKET SM4.37-40X8	
125	S42795101	1	Xケンテントク	HOME POSITION DOG, X	
126	S44924001	2	シメネジM3X5.5	SCREW, M3X5.5	
127	S42796001	1	Xセンサトリツケイタ	X-SENSOR SETTING PLATE	
128	062400812	2	ナベコ4X8	SCREW, PAN M4X8	
129	025040232	2	ヒラサガネチユウ4	WASHER, PLAIN M 4	
130	S59331001	1	XYオクリタイカバー-L	FEED BRACKET COVER, L :XY	
132	107272002	4	サラネジ4.37	SCREW, FLAT SM4.37	
133	S55939001	1	XYオクリタイカバー-R	FEED BRACKET COVER, R :XY	
135	107272002	4	サラネジ4.37	SCREW, FLAT SM4.37	
136	S59890001	2	アナホルト437-40X8	BOLT, SOCKET SM4.37-40X8	
137	025680232	2	ヒラサガネチユウ4.37	WASHER, PLAIN M 4.37	
142	048160242	2	トメワアナヨウC16	RETAINING RING, INTERNAL C16	
143	018501632	4	アナホルト5X16	BOLT, SOCKET M5X16	
144	025050232	4	ヒラサガネチユウ5	WASHER, PLAIN M 5	
145	018501432	2	アナホルト5X14	BOLT, SOCKET M5X14	
220	S59893001	4	アナホルト437-40X10	BOLT, SOCKET SM4.37-40X10	
221	028680242	4	ハネサガネ2-4.37	WASHER, SPRING 2-4.37	
222	148847001	4	サガネ	WASHER, PLAIN 4.76	
223	S59893001	4	アナホルト437-40X10	BOLT, SOCKET SM4.37-40X10	
224	028680242	4	ハネサガネ2-4.37	WASHER, SPRING 2-4.37	
225	148847001	4	サガネ	WASHER, PLAIN 4.76	
			<補給用部品>	<For supply parts>	
226	S59742000	1	リニアガイド311Lセット	LENEAR GUIDE SET, 311L	
226-1	S59637001	4	+サラコ4X8	SCREW, FLAT M4X8	

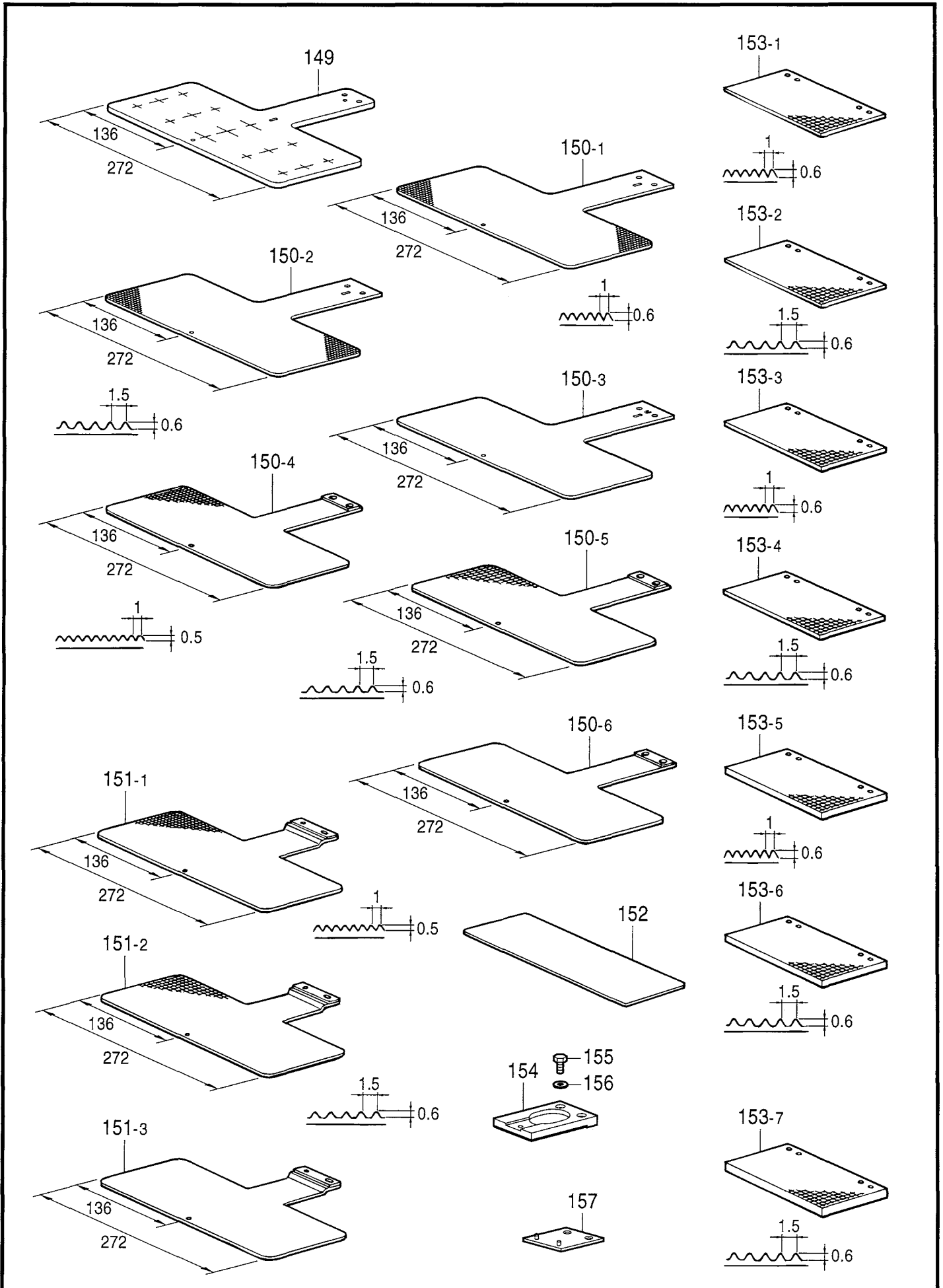

C11.送り関係 (311F-Lオプション部品) / Feed mechanism (Option parts of 311F-L)

REF.NO	CODE	Q'TY	品名	NAME OF PARTS	RM
149	S55161001	1	<ゲージ部品> ゲンテンキジユニタ311	<Gauge parts> H-POSITION STANDARD PLATE, 311	
150-1	S57723001	1	<送り板用アタッチメント> オクリイタFLAフランク	<For Feed plate attachment> FEED PLATE FLA BLANK	
150-2	S57724001	1	オクリイタFLBフランク	FEED PLATE FLB BLANK	
150-3	S57725001	1	オクリイタFLCフランク	FEED PLATE FLC BLANK	
150-4	S57720001	1	<送り板用アタッチメント 皿タイプ> オクリイタFLAフランク	<For Feed plate attachment of flat type> FEED PLATE FLA BLANK	
150-5	S57721001	1	オクリイタFLBフランク	FEED PLATE FLB BLANKL	
150-6	S57722001	1	オクリイタFLCフランク	FEED PLATE FLC BLANK	
151-1	S57726001	1	<ワンタッチ押え用> OTオクリイタFLAフランク	<For One-touch work clamp> OT-FEED PLATE FLA BLANK	
151-2	S57727001	1	OTオクリイタFLBフランク	OT-FEED PLATE FLB BLANK	
151-3	S57728001	1	OTオクリイタFLCフランク	OT-FEED PLATE FLC BLANK	
152	S45603001	1	オクリイタインナープレート	FEED PLATE INNER PLATE	
153-1	S57729001	2	<押え用フランク材> オサエフランクFLA-3.2	<The Blank for work clamp> WORK CLAMP BLANK, A-3.2 311L	
153-2	S57730001	2	オサエフランクFLB-3.2	WORK CLAMP BLANK, A-3.2 311L	
153-3	S57731001	2	オサエフランクFLA-4.0	WORK CLAMP BLANK, A-4.0 311L	
153-4	S57732001	2	オサエフランクFLB-4.0	WORK CLAMP BLANK, B-4.0R 311L	
153-5	S57733001	2	オサエフランクFLA-5.0	WORK CLAMP BLANK, A-5.0L 311FL	
153-6	S57734001	2	オサエフランクFLB-5.0	WORK CLAMP BLANK, B-5.0L 311FL	
153-7	S57735001	2	オサエフランクFLB-6.0	WORK CLAMP BLANK, 6.0 311FL	
154	S51804001	1	<押え、押え板用アタッチメント> オクリイタトリツケダイ	<Attachment for work clamp & feed plate> FEED PLATE SETTING BASE	
155	153403002	1	ボルト4.37X7	BOLT, SM4.37X7	
156	025680232	1	ヒラサガネチユウ4.37	WASHER, PLAIN M 4.37	
157	S57952001	1	OTオクリイタダイクミ	OT-FEED PLATE BRACKET ASSY	

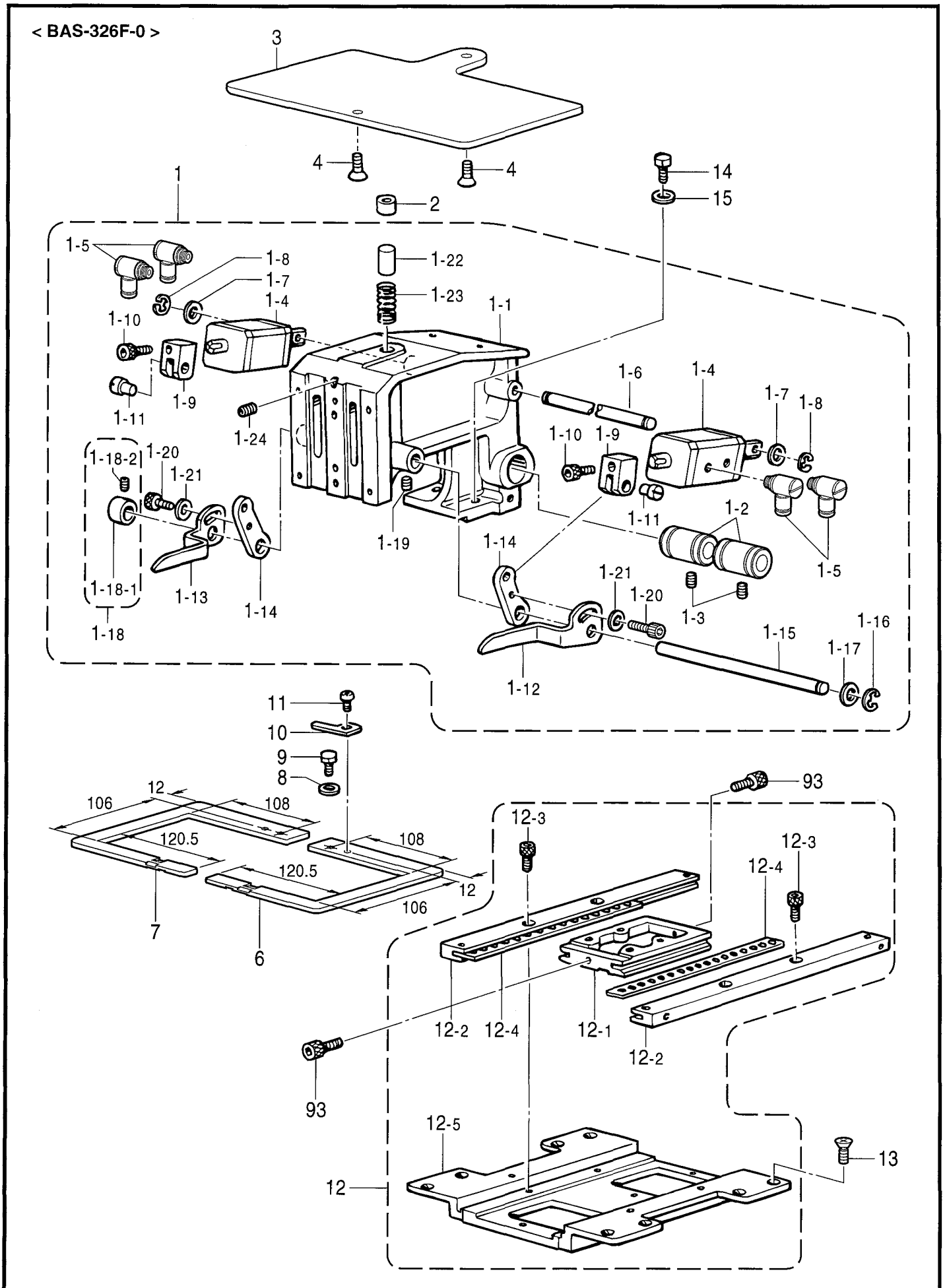

C12.送り関係 (326F-0) / Feed mechanism (326F-0)

REF.NO	CODE	Q'TY	品名	NAME OF PARTS	RM
1	S51027001	1	オサエウテ ^ク ミ	WORK CLAMP ARM ASSY	
1-1	S51028000	1	オサエウテ ^テ	WORK CLMP ARM	
1-2	S35183000	2	リニアブ ^ツ シユ12	LINEAR BUSH, 12	
1-3	011679312	2	トメネジ ^{3.57} ヒラ	SET SCREW, (FT) SM3.57	
1-4	S30950000	2	フラツトシリ ^ン ダ ^テ	FLAT CYLINDER	
1-5	S55533000	4	エルボ ⁵	ELBOW, M5	
1-6	S44326001	1	エアシ ^ン リ ^ン ダ ^サ サエシ ^ク	SUPPORT SHAFT	
1-7	146354001	2	サ ^カ ネ	WASHER, PLAIN 5	
1-8	048040342	2	トメ ^ワ E4	RETAINING RING, E4	
1-9	S30951001	2	シリ ^ン ダ ^ツ キ ^テ	CYLINDER JOINT	
1-10	018401632	2	アナ ^ホ ルト ^{4X16}	BOLT, SOCKET M4X16	
1-11	110168001	2	コロ ^シ ク	ROLLER SHAFT	
1-12	S44327001	1	オサエアケ ^レ バ ^ー UR	WORK CLAMP LIFTER LEVER, UR	
1-13	S44328001	1	オサエアケ ^レ バ ^ー UL	WORK CLAMP LIFTER LEVER, UL	
1-14	S17813001	2	オサエアケ ^レ バ ^ー D	LEVER, D	
1-15	S44329001	1	オサエアケ ^シ テン ^ジ ク	WORK CLAMP LIFTER SHAFT	
1-16	048050342	1	トメ ^ワ E5	RETAINING RING, E5	
1-17	143591001	1	スラスト ^リ ン ^ク	THRUST RING	
1-18	S21775001	1	セツ ^カ テ ^ー ク ^ミ	SET SCREW COLLAR ASSY	
1-18-1	139096001	1	セツ ^カ テ ^ー	SET SCREW COLLAR	
1-18-2	014680432	2	アナ ^ク ホ ^ミ 437-40X4	SET SCREW, SOCKET SM4.37-40X4	
1-19	014760632	1	アナ ^ク ホ ^ミ 595-28X6	SET SCREW, SOCKET SM5.95-28X6	
1-20	018400832	2	アナ ^ホ ルト ^{4X8}	BOLT, SOCKET M4X8	
1-21	025040132	2	ヒラ ^サ ガ ^ネ シヨ ^ウ 4	WASHER, PLAIN S 4	
1-22	S17816001	1	スライ ^ダ ー ^サ サエシ ^ク	SUPPORT SHAFT, SLIDER	
1-23	S18636101	1	スライ ^ダ ー ^オ シ ^ハ ネ	SPRING	
1-24	014760632	1	アナ ^ク ホ ^ミ 595-28X6	SET SCREW, SOCKET SM5.95-28X6	
2	S17815000	1	スライ ^ダ ー	SLIDER	
3	S51029001	1	オサエウテ ^サ サエ ^イ タ	WORK CLAMP ARM SUPPORT PLATE	
4	149482001	2	アナ ^ツ キ ^サ ラ ^ホ ルト ^{M6X15}	BOLT, FLAT W/SOCKET M6X15	
6	S51030001	1	326Lオサ ^エ R	WORK CLAMP, R 326L	
7	S51031001	1	326Lオサ ^エ L	WORK CLAMP, L 326L	
8	025680232	2	ヒラ ^サ ガ ^ネ チユ ^ウ 4.37	WASHER, PLAIN M 4.37	
9	153403002	2	ホ ^ル ト ^{4.37X7}	BOLT, SM4.37X7	
10	S10065001	2	イチ ^キ メ ^イ タ	POSITIONING PLATE	
11	062680512	2	ナ ^ベ コ ^{437-40X5}	SCREW, PAN SM4.37-40X5	
12	S44433401	1	326オ ^ク リ ^ダ イ ^ク ミ	FEED BRACKET ASSY, 326	
12-1	S44437401	1	Yオ ^ク リ ^ダ イ	Y-FEED BAR	
12-2	S44434101	2	326Yオ ^ク リ ^ア ン ^ナ イ ^ク ミ	Y-FEED GUIDE ASSY, 326	
12-3	S59890001	4	アナ ^ホ ルト ^{437-40X8}	BOLT, SOCKET SM4.37-40X8	
12-4	S44436000	2	326ク ^ロ ス ^ロ ー ^ラ	CROSS ROLLER, 326	
12-5	S44381001	1	オ ^ク リ ^ダ イ ^X	FEED BAR, X	
13	S59637001	8	+サ ^ラ コ ^{4X8}	SCREW, FLAT M4X8	
14	017761412	2	ホ ^ル ト ^{5.95X14}	BOLT, SM5.95X14	
15	025060132	2	ヒラ ^サ ガ ^ネ シヨ ^ウ 6	WASHER, PLAIN S 6	
93	S59890001	2	アナ ^ホ ルト ^{437-40X8}	BOLT, SOCKET SM4.37-40X8	

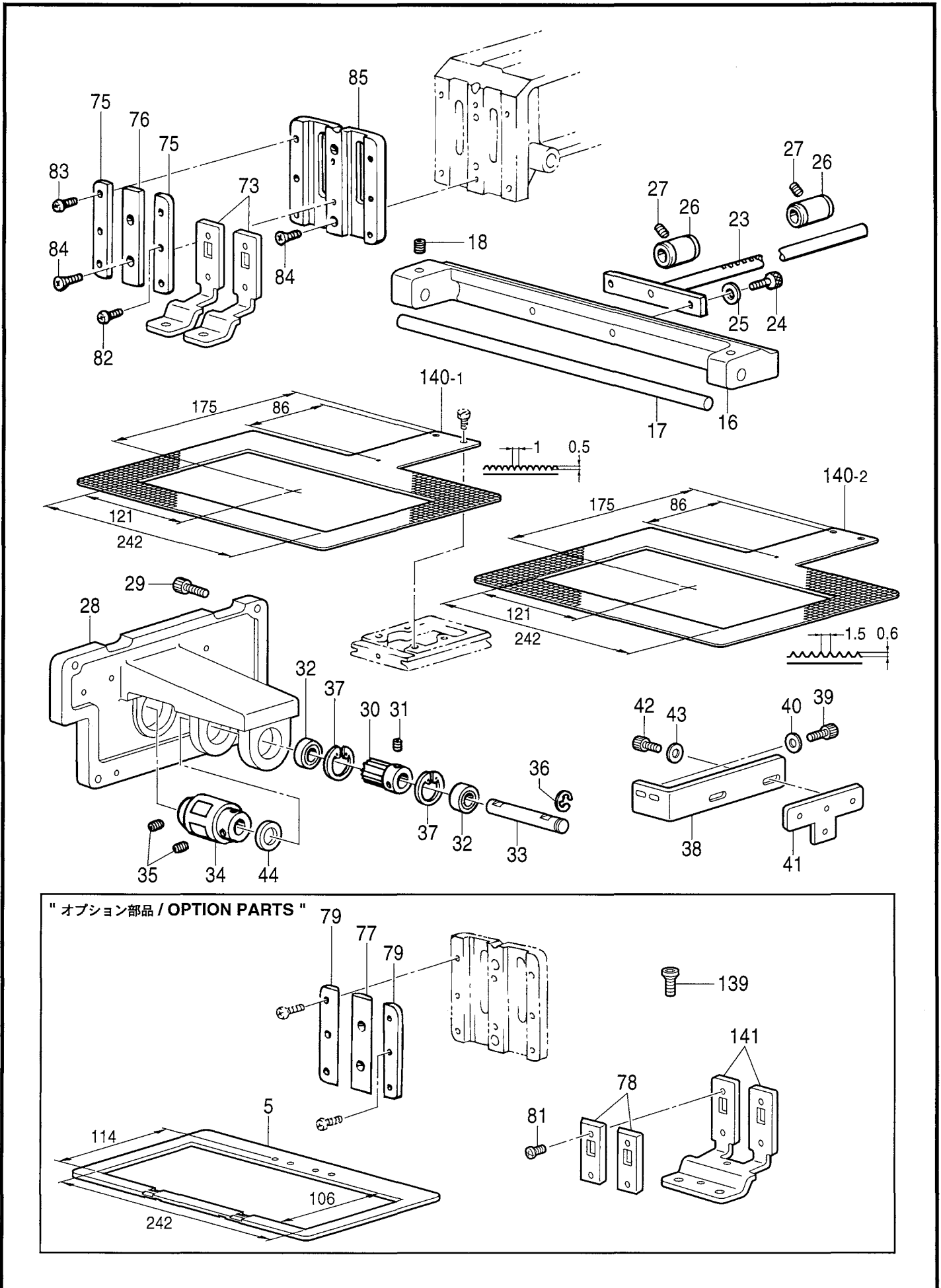

C13.送り関係 (326F-0) / Feed mechanism (326F-0)

REF.NO	CODE	QTY	品名	NAME OF PARTS	RM
16	S55946000	1	326Xオクリシクササエ	FEED SHAFT SUPPORT, 326X	
17	S51033001	1	326LXオクリシク	X-FEED SHAFT, 326L	
18	152718001	2	アナトメネジ5.95	SET SCREW, SOCKET SM5.95X5	
23	S51034101	1	Yクドウシク	Y-DRIVING SHAFT	
24	018501232	2	アナホルト5X12	BOLT, SOCKET M5X12	
25	025050232	2	ヒラザガネチユウ5	WASHER, PLAIN M 5	
26	S47112000	2	リニアブッシュ16	LINEAR BUSH, 16	
27	014760632	2	アナクホミ595-28X6	SET SCREW, SOCKET SM5.95-28X6	
28	S55947001	1	YクドウPモータブラケット	Y-DRIVING P-MOTOR BRACKET	
29	018061632	4	アナホルト6X16	BOLT, SOCKET M6X16	
30	S44443001	1	クドウギヤ	DRIVING GEAR	
31	014760632	2	アナクホミ595-28X6	SET SCREW, SOCKET SM5.95-28X6	
32	S17868001	2	ミニチュアタマシクウケ	BALL BEARING, MINATURE	
33	S55948001	1	Yクドウギヤシク	DRIVING SHAFT, Y	
34	S23446000	1	カツプリング	COUPLING	
35	014760632	4	アナクホミ595-28X6	SET SCREW, SOCKET SM5.95-28X6	
36	048080342	1	トメワE8	RETAINING RING, E8	
37	048220242	2	トメワアナヨウC22	RETAINING RING, INTERNAL C22	
38	S57850001	1	Yゲンテンブラケット	HOME POSITION BRACKET, Y	
39	018401032	2	アナホルト4X10	BOLT, SOCKET M4X10	
40	025040232	2	ヒラザガネチユウ4	WASHER, PLAIN M 4	
41	S44669001	1	Yセンサートリツケイタ	Y-SENSOR SETTING PLATE	
42	018400832	2	アナホルト4X8	BOLT, SOCKET M4X8	
43	025040232	2	ヒラザガネチユウ4	WASHER, PLAIN M 4	
44	S59650001	1	クドウギヤシクスペース	SPACER	
73	S56534001	2	オサエアシSE	WORK CLAMP, SE	
75	S42787001	2	オサエアシオサエイタA	WORK CLAMP GUIDE BRACKET, A	
76	S42884001	1	オサエアシオサエイタB	WORK CLAMP GUIDE PLATE, B	
82	062670712	2	ナベコ357-40X7	SCREW, PAN SM3.57-40X7	
83	062671212	4	ナベコ357-40X12	SCREW, PAN SM3.57-40X12	
84	107038003	4	サラネジ3.57	SCREW, FLAT SM3.57	
85	S56535001	1	オサエアシウケイタ	WORK CLAMP SUPPORT PLATE	
140-1	S55952001	1	<中厚物用> オクリイタ326A	<For Medium-weight materials> FEED PLATE, 326A	
140-2	S55953001	1	<厚物用> オクリイタ326B	<For Heavy-weight materials> FEED PLATE, 326B	
5	S51042001	1	“オプション部品” 326LオサエUN	“OPTION PARTS” WORK CLAMP, UN 326L	
77	S42798001	1	オサエアシオサエイタ	WORK CLAMP GUIDE BRACKET	
78	S56536001	2	オサエチヨウセツイタ	ADJUSTING PLATE	
79	S42800001	2	オサエスキマチヨウセツイタ	ADJUSTING PLATE	
81	062670612	4	ナベコ357-40X6	SCREW, PAN SM3.57-40X6	
139	S49955101	2	オクリイタシメネジ	SCREW, W/SOCKET SM4.37	
141	S56537001	1	オサエアシUN	WORK CLAMP, UN	

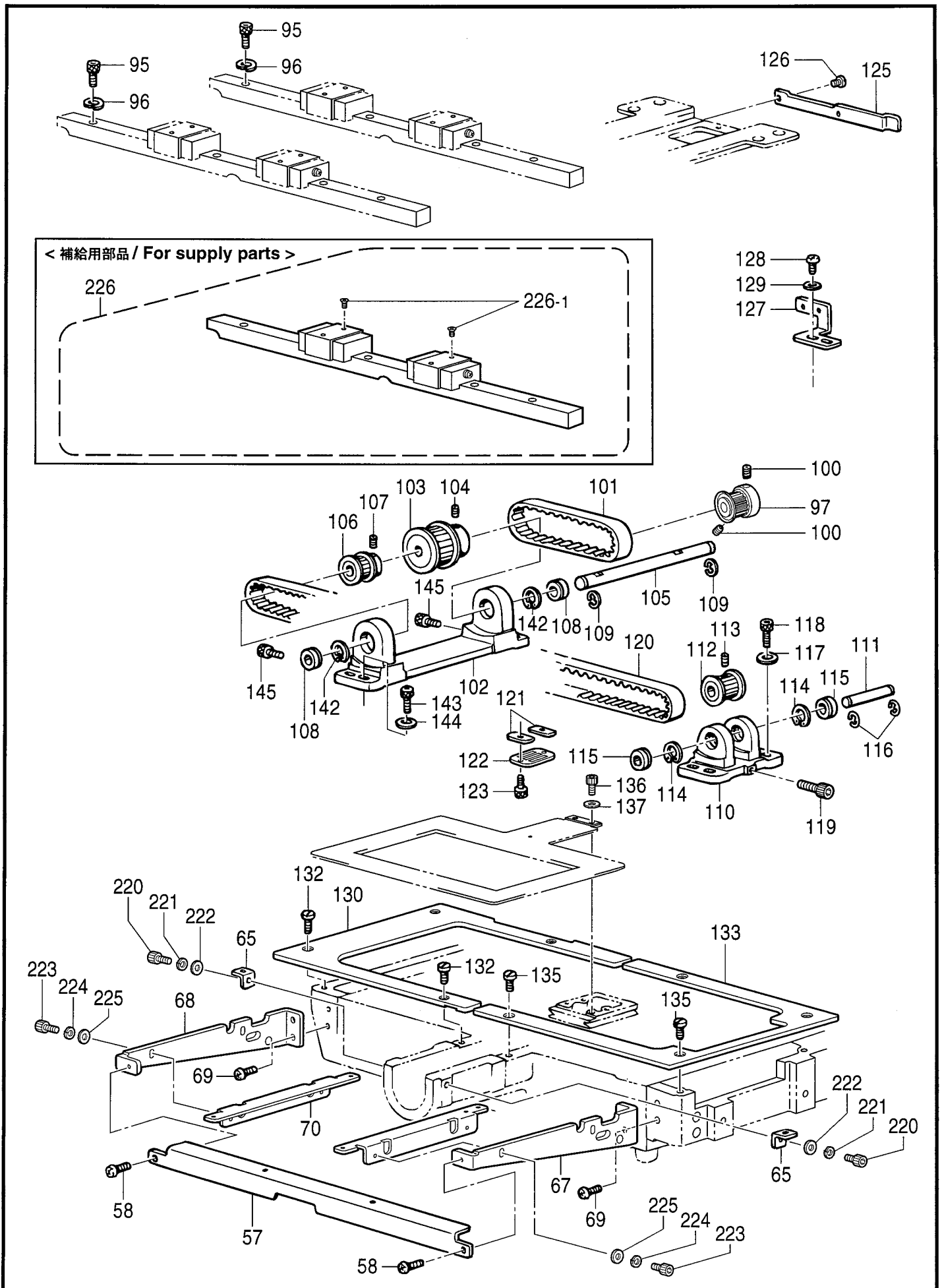

C14.送り関係 (326F-0) / Feed mechanism (326F-0)

REF.NO	CODE	QTY	品名	NAME OF PARTS	RM
57	S44757101	1	ホジヨイタササIM	SUPPORT PLATE GUIDE, M	
58	060680712	2	バ`イント437-40X7	SCREW, BIND SM4.37-40X7	
65	S10091201	4	ハリイタホジヨイタササE	AUXILIARY PLATE SUPPORT	
67	S55949001	1	ホジヨイタササIRD	AUXILIARY PLATE SUPPORT, RD	
68	S55950001	1	ホジヨイタササILD	AUXILIARY PLATE SUPPORT, LD	
69	062761012	4	ナヘ`コ595-28X10	SCREW, PAN SM5.95-28X10	
70	S55951001	2	ホジヨイタササIU	AUXILIARY PLATE SUPPORT, U	
95	018401436	11	アナホ`ルト4X14	BOLT, SOCKET M4X14	
96	028040246	11	ハ`ネサ`ガ`ネ2-4	WASHER, SPRING 2-4	
97	S57835101	1	Xタイミングプ`ーリア326	X-TIMING PULLEY, A 326	
100	014770632	2	アナクホ`ミ635-40X6	SET SCREW, SOCKET(CP) SM6.35X6	
101	S44456000	1	Xタイミングベ`ルトA326	X-TIMING BELT, A 326	
102	S44457000	1	Xプ`ーリダ`イル	X-PULLEY BRACKET, L	
103	S44458101	1	Xタイミングプ`ーリB326	X-TIMING PULLEY, B326	
104	014770632	2	アナクホ`ミ635-40X6	SET SCREW, SOCKET(CP) SM6.35X6	
105	S44459001	1	Xタイミングプ`ーリジ`ク	X-TIMING PULLEY SHAFT	
106	S17885101	1	タイミングプ`ーリア	TIMING PULLEY, A	
107	014770632	2	アナクホ`ミ635-40X6	SET SCREW, SOCKET(CP) SM6.35X6	
108	530138001	2	マイクロベ`アリング`8	BALL BEARING, MICRO 8	
109	048060342	2	トメワE6	RETAINING RING, E6	
110	S17886100	1	Xプ`ーリダ`イR	X-PULLEY BRACKET, R	
111	S17887001	1	Xプ`ーリジ`クR	X-PULLEY SHAFT, R	
112	S17888001	1	タイミングプ`ーリB	TIMING PULLEY, B	
113	014710532	2	アナクホ`ミ476-32X5	SET SCREW, SOCKET SM4.76-32X5	
114	048160242	2	トメワアナヨウC16	RETAINING RING, INTERNAL C16	
115	530138001	2	マイクロベ`アリング`8	BALL BEARING, MICRO 8	
116	048060342	2	トメワE6	RETAINING RING, E6	
117	025050232	4	ヒラサ`ガ`ネチユウ5	WASHER, PLAIN M 5	
118	018501632	4	アナホ`ルト5X16	BOLT, SOCKET M5X16	
119	018501632	1	アナホ`ルト5X16	BOLT, SOCKET M5X16	
120	S44624000	1	Xタイミングベ`ルト311L	X-TIMING BELT, B 311L	
121	S10078001	2	Tベ`ルトスベ`ーサ	T-BELT SPACER	
122	S47115001	1	Yベ`ルトホルダ`	Y-BELT HOLDER	
123	S59890001	2	アナホ`ルト437-40X8	BOLT, SOCKET SM4.37-40X8	
125	S42795101	1	Xケンテント`ク	HOME POSITION DOG, X	
126	S44924001	2	シメネジ`M3X5.5	SCREW, M3X5.5	
127	S42796001	1	Xセンサートリツケイタ	X-SENSOR SETTING PLATE	
128	062400812	2	ナヘ`コ4X8	SCREW, PAN M4X8	
129	025040232	2	ヒラサ`ガ`ネチユウ4	WASHER, PLAIN M 4	
130	S51040001	1	XYオク`リダ`イカバー`L	XY-FEED BRACKET COVER, L	
132	106629002	4	シメネジ`4.37	SCREW, SM4.37	
133	S51041001	1	XYオク`リダ`イカバー`R	XY-FEED BRACKET COVER, R	
135	106629002	4	シメネジ`4.37	SCREW, SM4.37	
136	S59890001	2	アナホ`ルト437-40X8	BOLT, SOCKET SM4.37-40X8	
137	025680232	2	ヒラサ`ガ`ネチユウ4.37	WASHER, PLAIN M 4.37	
142	048160242	2	トメワアナヨウC16	RETAINING RING, INTERNAL C16	
143	018501632	4	アナホ`ルト5X16	BOLT, SOCKET M5X16	
144	025050232	4	ヒラサ`ガ`ネチユウ5	WASHER, PLAIN M 5	
145	018501432	2	アナホ`ルト5X14	BOLT, SOCKET M5X14	
220	S59893001	4	アナホ`ルト437-40X10	BOLT, SOCKET SM4.37-40X10	
221	028680242	4	ハ`ネサ`ガ`ネ2-4.37	WASHER, SPRING 2-4.37	
222	148847001	4	サ`カ`ネ	WASHER, PLAIN 4.76	
223	S59893001	4	アナホ`ルト437-40X10	BOLT, SOCKET SM4.37-40X10	
224	028680242	4	ハ`ネサ`ガ`ネ2-4.37	WASHER, SPRING 2-4.37	
225	148847001	4	サ`カ`ネ	WASHER, PLAIN 4.76	
226	S59742000	1	<補給用部品> リニアガ`イド`311Lセット	<For Supply parts> LENEAR GUIDE SET, 311L	
226-1	S59637001	4	+サラコ4X8	SCREW, FLAT M4X8	

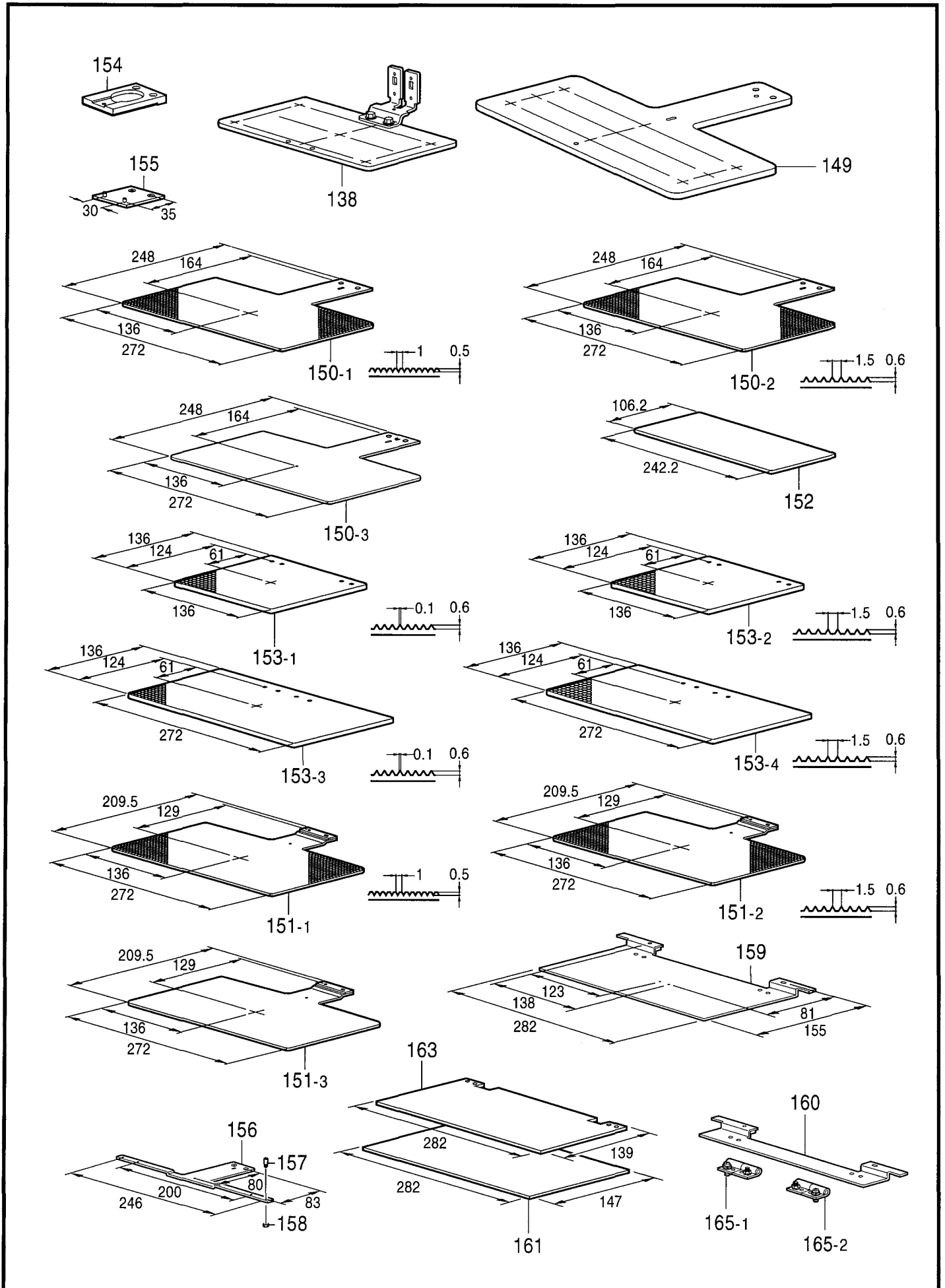

C15.送り関係 (326F-0用オプション部品) / Feed mechanism (Option parts of 326F-0)

REF.NO	CODE	QTY	品名	NAME OF PARTS	RM
138	S56538001	1	<ゲージ部品> ゲンテンキジユンイタクミ	<Gauge parts> H-POSITION STAND PLATE ASSY	※
149	S55954001	1	ゲンテンキジユンイタ326	H-POSITION STANDARD PLATE, 326	
150-1	S57844001	1	<送り板用アタッチメント> オクリイタ326Aブラック	<Attachment for feed plate> FEED PLATE BLANK, 326A	
150-2	S57845001	1	オクリイタ326Bブラック	FEED PLATE BLANK, 326B	
150-3	S57846001	1	オクリイタ326Cブラック	FEED PLATE BLANK, 326C	
151-1	S51048101	1	<OT送り板用アタッチメント> OTオクリイタLAブラック	<Attachment for one-touch feed plate> OT-FEED PLATE BLANK, A :326L	
151-2	S51049101	1	OTオクリイタLBブラック	OT-FEED PLATE BLANK, B :326L	
151-3	S51050101	1	OTオクリイタLCブラック	OT-FEED PLATE BLANK, C :326L	
152	S48555000	1	オクリイタインナープレート	FEED PLATE INNER PLATE	
153-1	S51051001	1	<押え用ブラック材> オサエブラックLA3.2SE	<For Work clamp blank > WORK CLAMP BLANK, SE A-3.2-L	
153-1	S51053001	1	オサエブラックLA4.0SE	WORK CLAMP BLANK, SE A-4.0-L	
153-1	S51055001	1	オサエブラックLA5.0SE	WORK CLAMP BLANK, SE A-5.0-L	
153-1	S51057001	1	オサエブラックLA6.0SE	WORK CLAMP BLANK, SE A-6.0-L	
153-2	S51052001	1	オサエブラックLB3.2SE	WORK CLAMP BLANK, SE B-3.2-L	
153-2	S51054001	1	オサエブラックLB4.0SE	WORK CLAMP BLANK, SE B-4.0-L	
153-2	S51056001	1	オサエブラックLB5.0SE	WORK CLAMP BLANK, SE B-5.0-L	
153-2	S51058001	1	オサエブラックLB6.0SE	WORK CLAMP BLANK, SE B-6.0-L	
153-3	S51059001	1	オサエブラックLA3.2UN	WORK CLAMP BLANK, UN A-3.2-L	
153-3	S51061001	1	オサエブラックLA4.0UN	WORK CLAMP BLANK, UN A-4.0-L	
153-3	S51063001	1	オサエブラックLA5.0UN	WORK CLAMP BLANK, UN A-5.0-L	
153-3	S51065001	1	オサエブラックLA6.0UN	WORK CLAMP BLANK, UN A-6.0-L	
153-4	S51060001	1	オサエブラックLB3.2UN	WORK CLAMP BLANK, UN B-3.2-L	
153-4	S51062001	1	オサエブラックLB4.0UN	WORK CLAMP BLANK, UN B-4.0-L	
153-4	S51064001	1	オサエブラックLB5.0UN	WORK CLAMP BLANK, UN B-5.0-L	
153-4	S51066001	1	オサエブラックLB6.0UN	WORK CLAMP BLANK, UN B-6.0-L	
154	S51804001	1	<送り板用取付台> オクリイタトリツケダイ	<Attachment for feed plate> FEED PLATE SETTING BASE	
155	S57952001	1	<OT送り板用取付台> OTオクリイタダイクミ	<Attachment for one-touch feed plate> OT-FEED PLATE BRACKET ASSY	
156	S57849101	1	カセットジグイタ	CASSETTE HOLDER PLATE	
157	S13007001	2	カセットジグピン	CASSETTE HOLDER PIN	
158	021660306	2	3シュナツト318-40	NUT, 3 SM3.18-40	
159	S14392201	1	カセットイタD-A180	CASSETTE PLATE, D-A180	
160	S14388101	1	カセットイタD-B180	CASSETTE PLATE, D-B180	
161	S14386000	1	カセットシタイトA180	CASSETTE LOWER PLATE, A-180	
161	S14387000	1	カセットシタイトB180	CASSETTE LOWER PLATE, B-180	
163	S14389000	1	カセットイタU-A180	CASSETTE PLATE, U-A180	
163	S14390000	1	カセットイタU-B180	CASSETTE PLATE, U-B180	
165-1	152632001	1	チヨウハンクミミギ	HINGE ASSY, R	
165-2	152633001	1	チヨウハンクミヒダリ	HINGE ASSY, L	

BAS-326F-0-202

☆RM欄に※が付いている部品は、精密な組み立て調整がして有りますので絶対に分解しないで下さい。

☆Parts which have an asterisk(※)in the RM colum are parts which have been assembled and adjusted to high precisions.
These parts should never be disassembled.

< 電磁式用 / For Solenoid type >

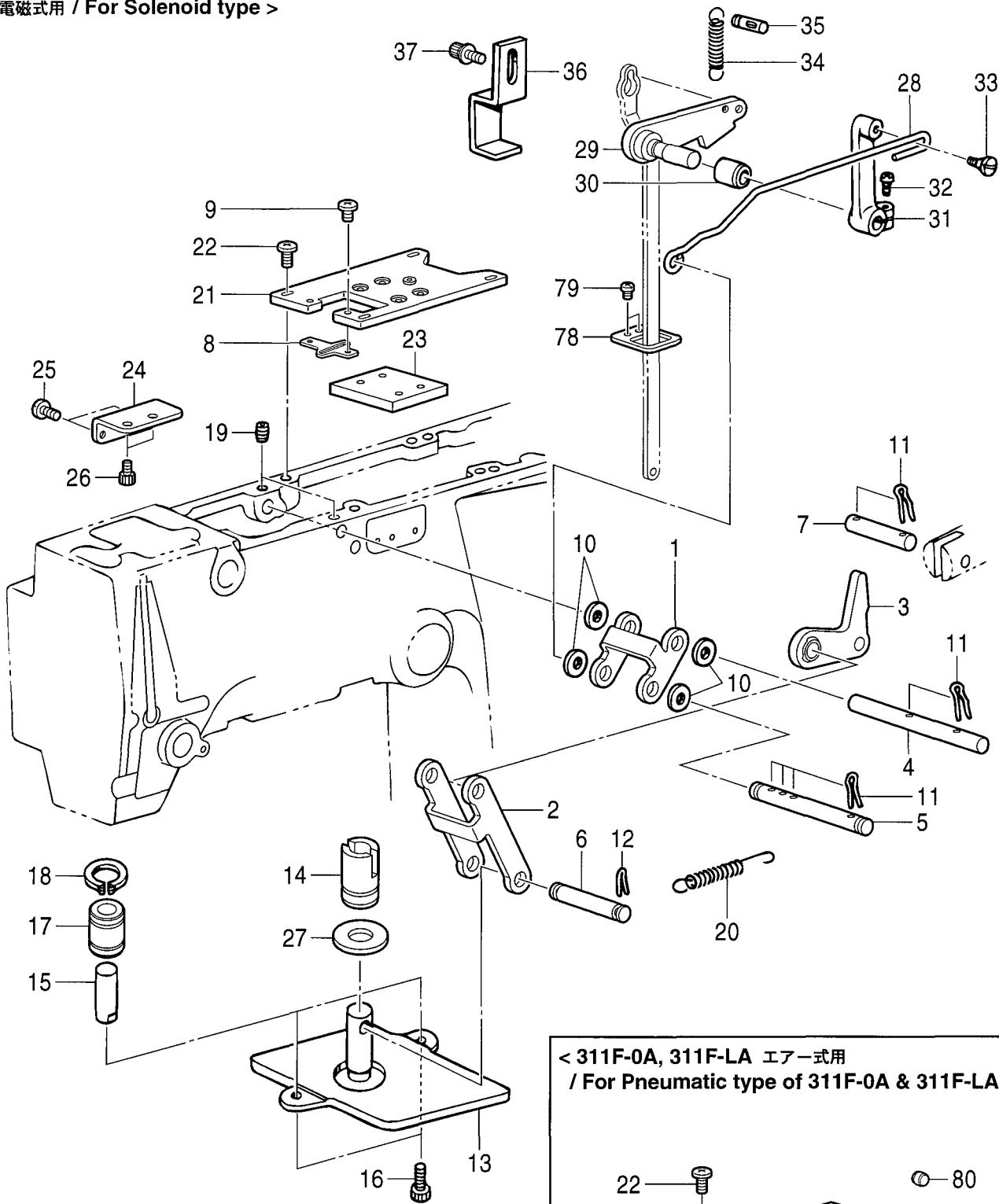

< 326F-0エア-式用 / For Pneumatic type of 326F-0 >

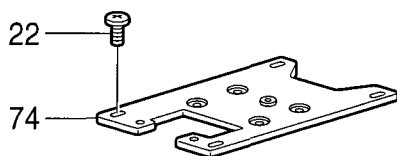

< 311F-0A, 311F-LA エア-式用 / For Pneumatic type of 311F-0A & 311F-LA >

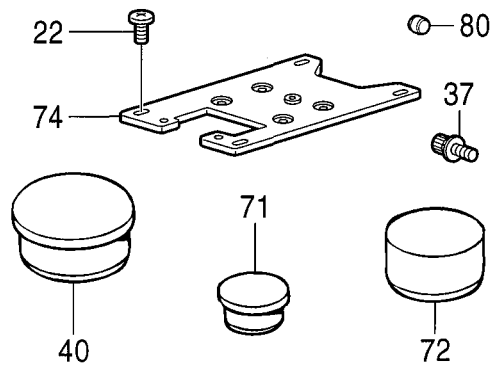

D1.押え上げ関係 / Work clamp lifter mechanism

REF.NO	CODE	Q'TY	品名	NAME OF PARTS	RM
			<電磁式用>	<For Solenoid type>	
1	S49630001	1	リンクA	LINK, A	
2	S49631001	1	リンクB	LINK, B	
3	S49632001	1	リンクCクミ	LINK ASSY, C	
4	S49635001	1	リンクシクA	LINK SHAFT, A	
5	S55200001	1	リンクシクB	LINK SHAFT, B	
6	S49637001	1	リンクシクC	LINK SHAFT, C	
7	S49638001	1	リンクシクD	LINK SHAFT, D	
8	S49643001	1	ガイド	GUIDE	
9	060680712	2	バインド437-40X7	SCREW, BIND SM4.37-40X7	
10	100281001	4	ワッシャ	WASHER, PLAIN	
11	S37968001	8	スナップピン8	SNAP PIN, 8	
12	S19662001	2	スナップピン5	SNAP PIN, 5	
13	S42747201	1	オサエイタ	WORK CLAMP PLATE	
14	S55157000	1	オサエイタヨウメタル	BUSH	
15	S41239001	2	アンナインク12	GUIDE SHAFT, 12	
16	018501036	2	アナホルト5X10	BOLT, SOCKET M5X10	
17	S35183000	2	リアブッシュ12	LINEAR BUSH, 12	
18	048200142	2	トモワシクヨウC20	RETAINING RING, EXTERNAL C20	
19	014760632	2	アナクホミ595-28X6	SET SCREW, SOCKET SM5.95-28X6	
20	S10105001	2	リンクモトシバネ	SPRING, EXTENSION	
21	S55171001	1	ソレノイドトリツケイタ	SOLENOID SETTING PLATE, A	
22	060681212	4	バインド437-40X12	SCREW, BIND SM4.37-40X12	
23	S55131001	1	スペーサ	SPACER	
24	S55172001	1	ソレノイドトリツケイタB	SOLENOID SETTING PLATE, B	
25	060501016	2	バインドM5X10	SCREW, BIND M5X10	
26	018500836	2	アナホルト5X8	BOLT, SOCKET M5X8	
27	S59763000	1	オサエアケストツパ-ゴム	W-CLAMP LIFTER STOPPER RUBBER	
28	S55169101	1	ロッド	ROD	
29	S55170001	1	オサエアケレバー	WORK CLAMP LIFTER LEVER	
30	140263000	1	オサエウデシクメタルL	BUSH, L:W-CLAMP ARM SHAFT	
31	S10108001	1	オサエアケレバーウデ	PRESSER LIFTER LEVER ARM	
32	062681212	1	ナベコ437-40X12	SCREW, PAN SM4.37-40X12	
33	115559002	1	ダンネシ4.76	SHOULDER SCREW, SM4.76	
34	S10109001	1	オサエアケレバーバネ	PRESSER LIFTER SPRING	
35	159379001	1	ミソツキピンBX6X18	PIN, DOWEL BX6X18	
36	S10110101	1	オサエアケストツパ	PRESSER LIFTER STOPPER	
37	S55476002	2	アナホルトサクミ6X12	BOLT, SOCKET (S/P WASHER)M6X12	
78	S42883001	1	レンカンアンナイタ	CONNECTING ROD GUIDE PLATE	
79	062400612	2	ナベコM4X6	SCREW, PAN M4X6	
			<311F-0A, 311F-LA エア式用>	<For Pneumatic type of 311F-0A & 311F-LA>	
22	060681212	4	バインド437-40X12	SCREW, BIND SM4.37-40X12	
37	S55476002	2	アナホルトサクミ6X12	BOLT, SOCKET (S/P WASHER)M6X12	
40	S10125000	3	ゴムセン21	RUBBER CAP, 21	
71	104450101	2	ゴムセン8	RUBBER CAP, 8	
72	S00313001	1	ゴムセン16.8	RUBBER CAP, 16.8	
74	S49641001	1	ソレノイドトリツケイタ	SOLENOID SETTING PLATE, A	
80	140327001	1	ゴムセン6.3	RUBBER CAP, 6.3	
			<326F-0 エア式用>	<For Pneumatic type of 326F-0>	
22	060681212	4	バインド437-40X12	SCREW, BIND SM4.37-40X12	
74	S49641001	1	ソレノイドトリツケイタ	SOLENOID SETTING PLATE, A	

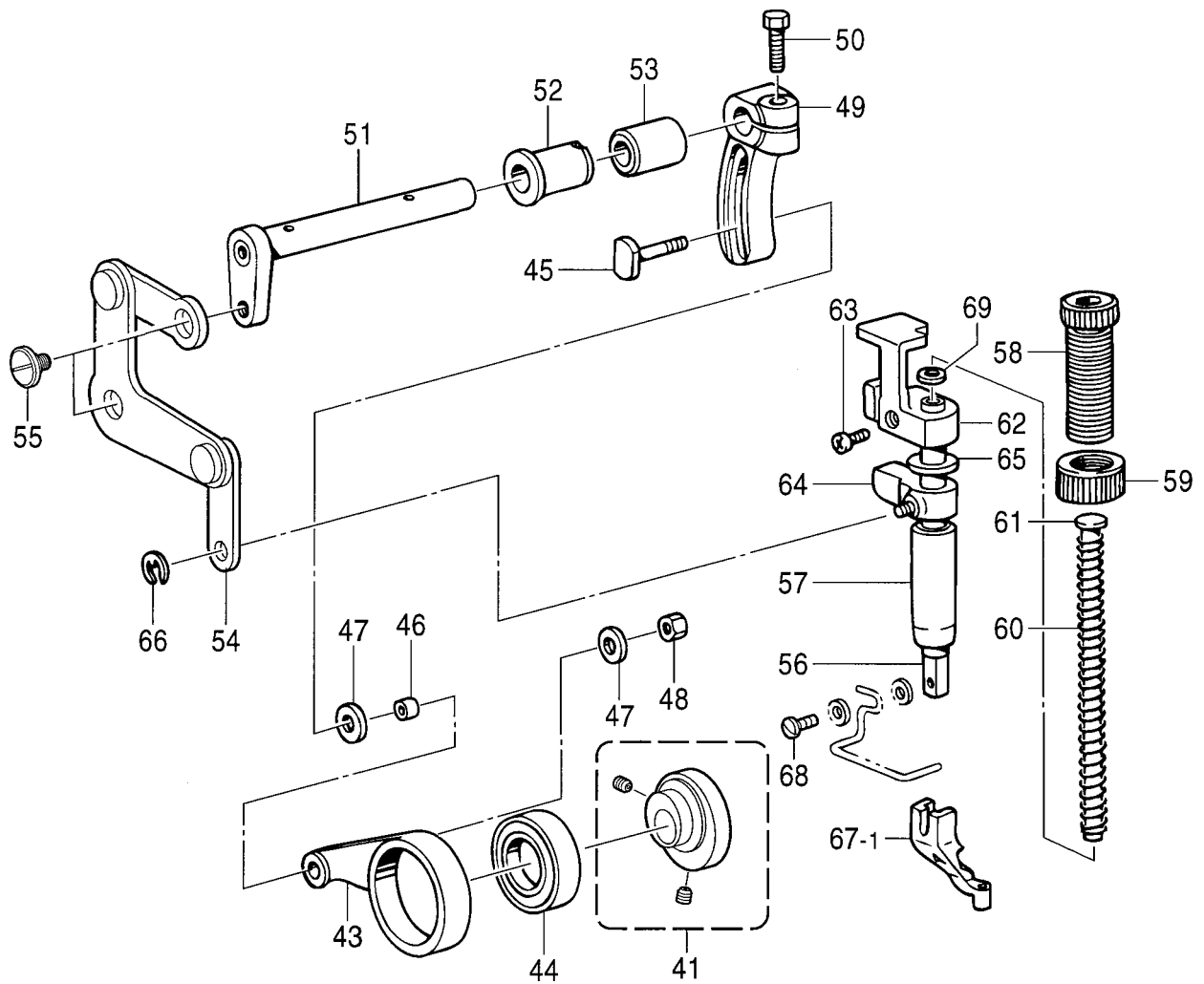

" オプション部品 / OPTION PARTS "

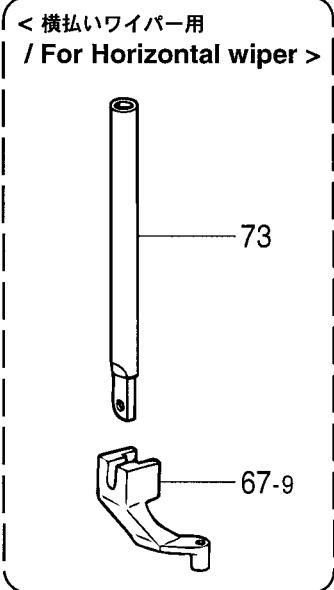
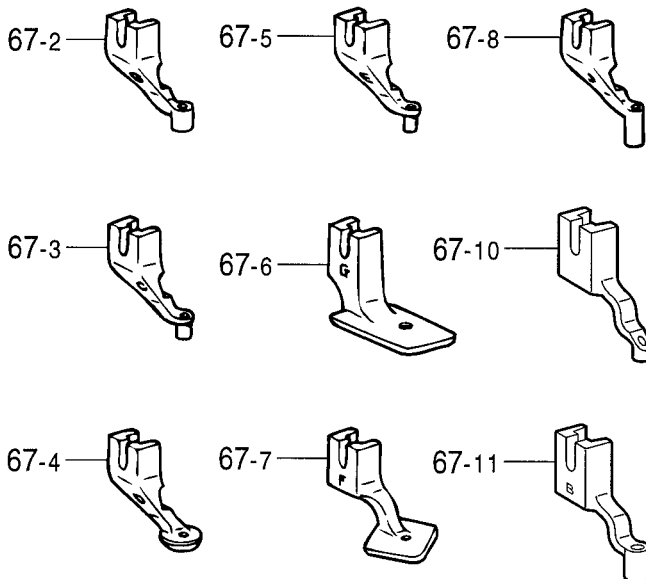

D2.押え上げ関係 / Work clamp lifter mechanism

REF.NO	CODE	Q'TY	品名	NAME OF PARTS	RM
41	S59103001	1	カンケツオサエカムBクミ	STEPPING W-CLAMP CAM ASSY, B	
43	S43693000	1	カンケツオサエレンカン	STEPPING WORK CLAMP CON. ROD	
44	623033000	1	タマシクウケ6805VV	BALL BEARING, 6805VV	
45	150460001	1	U-UDオクリレバ-ジク	U-UD FEED LIFTER LEVER SHAFT	
46	150461001	1	オクリコロ	FEED ROLLER	
47	107453001	2	サカネ	WASHER	
48	021750102	1	1シユナツト556-32	NUT, 1 SM5.56-32	
49	S17871101	1	カンケツオサエウテ`R	STEPPING WORK CLAMP ARM, R	
50	017751412	1	ボルト5.56X14	BOLT, SM5.56X14	
51	S42839101	1	カンケツオサエウテ`F	STEPPING WORK CLAMP ARM, F	
52	148196000	1	ウワメスサド`ウウテ`メタルL	BUSH, L	
53	148197000	1	ウワメスサド`ウウテ`メタルR	BUSH, R	
54	S55144001	1	カンケツリンククミ	STEPPING W-CLAMP LINK ASSY	
55	S54393001	2	ダンネジ`5.56	SHOULDER SCREW, SM5.56	
56	111466101	1	オサエホ`ウ	PRESSER BAR	
57	145472001	1	オサエホ`ウメタル	PRESSER BAR BUSH	
58	S31012001	1	オサエチヨウセツネジ`	PRESSER ADJUSTING SCREW	
59	S31013001	1	チヨウセツネジ`ツマミナツト	PRESSER ADJUSTING NUT	
60	S10111101	1	オサエハ`ネ	PRESSER BAR SPRING	
61	S10112001	1	オサエハ`ネアンナイ	PRESSER BAR SPRING GUIDE	
62	S10113301	1	オサエホ`ウダ`キ	PRESSER BAR GUIDE BRACKET	
63	062681212	1	ナベ`コ437-40X12	SCREW, PAN SM4.37-40X12	
64	S10371001	1	オサエホ`ウリフター	PRESSER BAR LIFTER	
65	S10372100	1	オサエホ`ウダ`キクツシヨシ	CUSHION	
66	048040342	1	トメワE4	RETAINING RING, E4	
67-1	S42843001	1	オサエアシA	PRESSER FOOT, A	
68	S13399001	1	シメネジ`3.57X12	SCREW, SM3.57X12	
69	S03677001	1	サカネ	WASHER	
			“オプション部品”	“OPTION PARTS”	
67-2	S42844001	1	オサエアシB	PRESSER FOOT, B	
67-3	S42845001	1	オサエアシC	PRESSER FOOT, C	
67-4	S42846001	1	オサエアシD	PRESSER FOOT, D	
67-5	S42847001	1	オサエアシE	PRESSER FOOT, E	
67-6	158592001	1	オサエアシG	PRESSER FOOT, G	
67-7	157237001	1	オサエアシF	WROK CLAMP, F	
67-8	S42848001	1	オサエアシJ	PRESSER FOOT, J	
67-10	S40214001	1	オサエアシA-CUT	PRESSER FOOT, A-CUT	
67-11	S49448001	1	オサエアシB-L	PRESSER FOOT, B-L	
			<横払いワイパー用>	<For Horizontal wiper>	
67-9	S42849101	1	オサエアシXA	WORK CLAMP, XA	
73	S42880001	1	オサエホ`ウヨコ	PRESSER BAR, SIDE	

E . 下軸関係 / Lower shaft mechanism

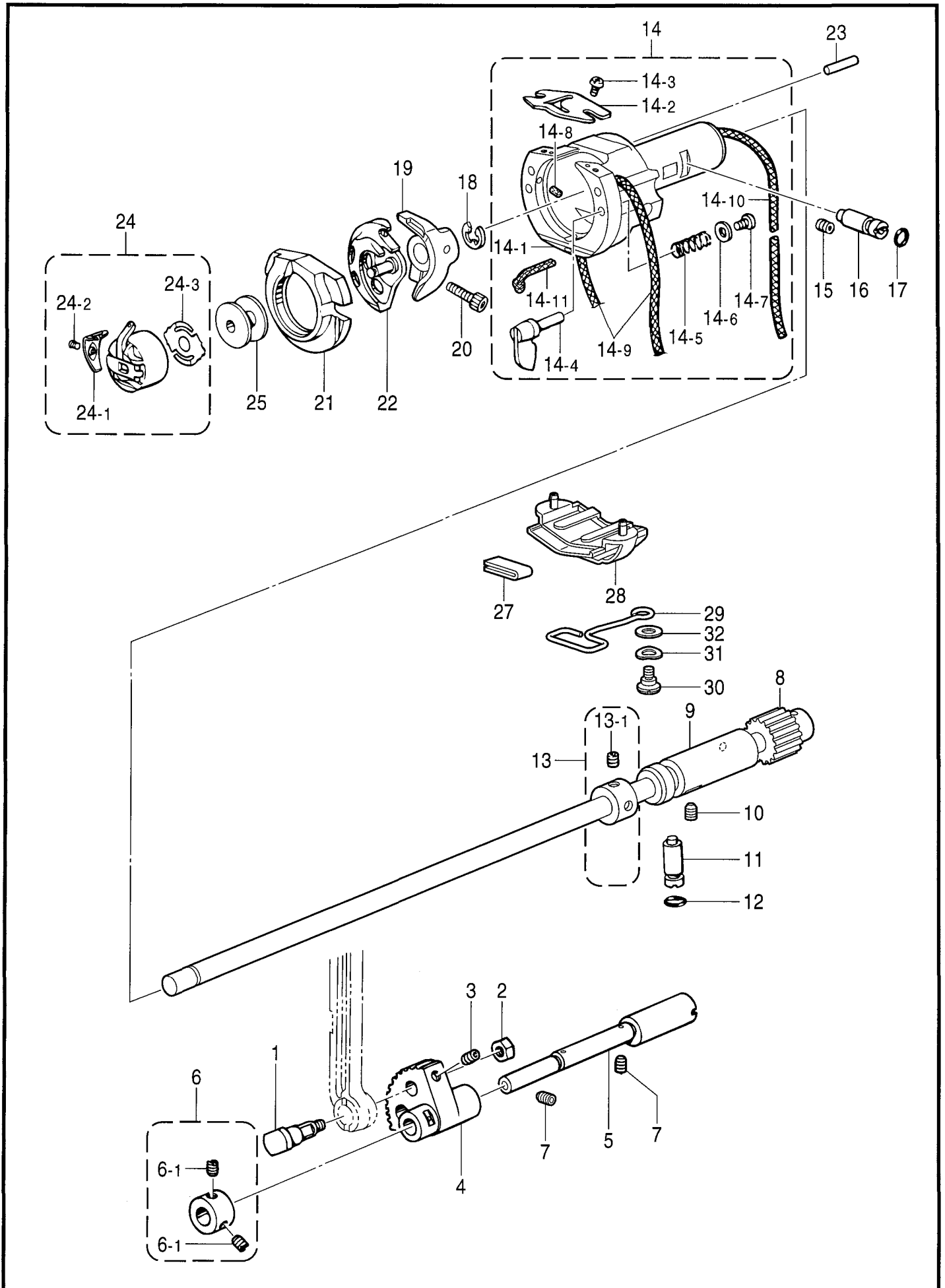

BAS-311F-0-305

E. 下軸関係 / Lower shaft mechanism

REF.NO	CODE	QTY	品名	NAME OF PARTS	RM
1	141786001	1	クランクロット ^ダ ンネジ	SHOULDER SCREW	
2	100090004	1	ナツ7.14	NUT, SM7.14	
3	014680632	1	アナクホ ^ミ 437-40X6	SET SCREW, SOCKET SM4.37-40X6	
4	152245101	1	ヨウト ^{ウキ} ヤ	ROCK GEAR	
5	S37978251	1	ヨウト ^{ウキ} ヤシク	ROCK GEAR SHAFT	
6	181995001	1	セツカラ ^{クミ}	SET SCREW COLLAR ASSY	
6-1	101706001	2	トメネジ ^{6.35}	SET SCREW, SM6.35-40X5.5	
7	014760632	1	アナクホ ^ミ 595-28X6	SET SCREW, SOCKET SM5.95-28X6	
8	S53207001	1	シタシク ^{クミ}	LOWER SHAFT ASSY	
9	S55213001	1	シタシク ^{メタル}	LOWER SHAFT BUSH	
10	014760632	1	アナクホ ^ミ 595-28X6	SET SCREW, SOCKET SM5.95-28X6	
11	152678201	1	カマチヨウ ^{セツ} ク	ADJUSTING STUD	
12	081003670	1	リング ^{PW3}	O-RING, PW3	
13	S49609001	1	セツカラ ^{クミ}	SET SCREW COLLAR ASSY	
13-1	014770632	2	アナクホ ^ミ 635-40X6	SET SCREW, SOCKET SM6.35-40X6	
14	S55217201	1	オオカマ ^{タイ} クミ	SHUTTLE RACE BASE ASSY	
14-1	S55216101	1	オオカマ ^{タイ}	SHUTTLE RACE BASE	
14-2	S02429101	1	カマ ^{イト} アンナイ	SHUTTLE RACE THREAD GUIDE	
14-3	062660412	2	ナベ ^コ 318-40X4	SCREW, PAN SM3.18-40X4	
14-4	152683101	2	オオカマ ^{トリツケ} ツメ	S-RACE BASE SETTING CLAW	
14-5	152684101	2	オオカマ ^{トリツケ} バネ	COMPRESSION SPRING	
14-6	402887001	2	ザ ^カ ネ3.2	WASHER, 3.2	
14-7	062660712	2	ナベ ^コ 318-40X7	SCREW, PAN SM3.18-40X7	
14-8	S09043000	2	フェルト	FELT	
14-9	S57965000	2	クミ ^{ヒモ} 3X3	WICK, 3X3 L=515	
14-10	S57965000	1	クミ ^{ヒモ} 3X3	WICK, 3X3 L=515	
14-11	S49685000	1	クミ ^{ヒモ} 3X3	WICK, 3X3 L=100	
15	014760632	1	アナクホ ^ミ 595-28X6	SET SCREW, SOCKET SM5.95-28X6	
16	152678201	1	カマチヨウ ^{セツ} ク	ADJUSTING STUD	
17	081003670	1	リング ^{PW3}	O-RING, PW3	
18	048070342	1	ト ^ワ E7	RETAINING RING, E7	
19	S55215001	1	ト ^{ライバ} ーHR	DRIVER, HR	
20	018501232	1	アナ ^ボ ルト5X12	BOLT, SOCKET M5X12	
				<For Medium-weight materials of 311F-0 & 326F-0>	
21	152682101	1	オオカ ^マ A	SHUTTLE RACE BASE, A	
22	SA2173001	1	S59161カマ ^{ハコ} クミ	SHUTTLE HOOK ASSY, W/BOXS59161	
			<311F-0, 311F-L, 326F-0 厚物、極厚物用>	<For Heavy-weight material & extra heavy- weight materials 311F-0, 311F-L & 326F-0>	
21	152686101	1	オオカ ^マ B	SHUTTLE RACE BASE, B	
22	SA1890001	1	S59162カマ ^{ハコ} クミ	SHUTTLE HOOK ASSY, W/BOXS59162	
23	S16290001	1	ニ ^ー トルロー ^ラ ー4X19.8	NEEDLE ROLLER, 4X19.8	
			<311F-0極厚物用>	<For Extra heavy-weight materials of 311F-0>	
24	S59222001	1	ボ ^{ビン} ケース ^{クミ} LB	BOBBIN CASE ASSY, LB	
24-1	S16075101	1	ケ ^ー スチヨウ ^シ バ ^ネ B	TENSION SPRING, B	
24-2	S16492101	1	ボ ^{ビン} ケース ^バ ネ ^{ネジ}	BOBBIN CASE SPRING SCREW	
24-3	S15667001	1	クウ ^{テン} ボ ^ウ シ ^バ ネ	ANTI-SPIN SPRING	
			<311F-0, 311F-L, 326F-0 中厚物、厚物用>	<For Medium & heavy-weight materials 311F-0, 311F-L & 326F-0>	
24	S59221001	1	ボ ^{ビン} ケース ^{クミ} LC	BOBBIN CASE ASSY, LC	
24-1	S48664001	1	ケ ^ー スチヨウ ^シ バ ^ネ AN	TENSION SPRING, AN	
24-2	S16492101	1	ボ ^{ビン} ケース ^バ ネ ^{ネジ}	BOBBIN CASE SPRING SCREW	
24-3	S15667001	1	クウ ^{テン} ボ ^ウ シ ^バ ネ	ANTI-SPIN SPRING	

E . 下軸關係 / Lower shaft mechanism

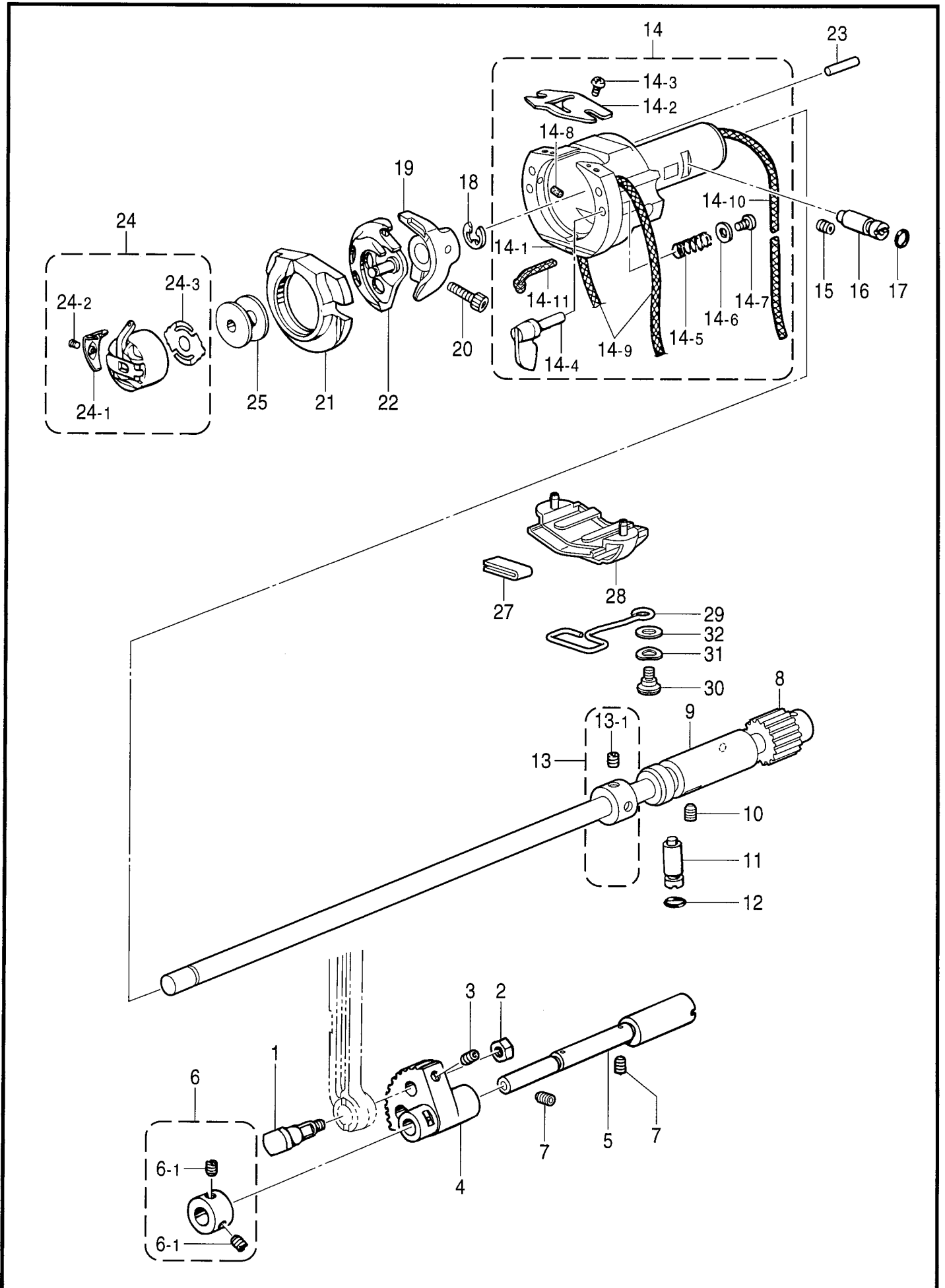

BAS-311F-0-305

E. 下軸関係 / Lower shaft mechanism

REF.NO	CODE	Q'TY	品名	NAME OF PARTS	RM
25	S15665001	1	<311F-0, 311F-L, 326F-0 中厚物、厚物用> ホビンLA	< For Medium & heavy-weight materials 311F-0, 311F-L & 326F-0> BOBBIN, LA	
25	S15666001	1	<311F-0極厚物用> ホビンLB	< For Extra heavy-weight materials of 311F-0> BOBBIN, LB	
27	S55658000	1	カマフエルト	SHUTTLE HOOK FELT	
28	S55214000	1	カマフエルトササエ	SHUTTLE HOOK FELT HOLDER	
29	S55140001	1	サポート	SUPPORT	
30	123882001	1	ダンネジ4.37	STUD SCREW 4.37	
31	103810002	1	ナミカタハネサガネ	WAVE WASHER	
32	025770232	1	ヒラサガネネユウ6.35	WASHER, PLAIN M 6.35	

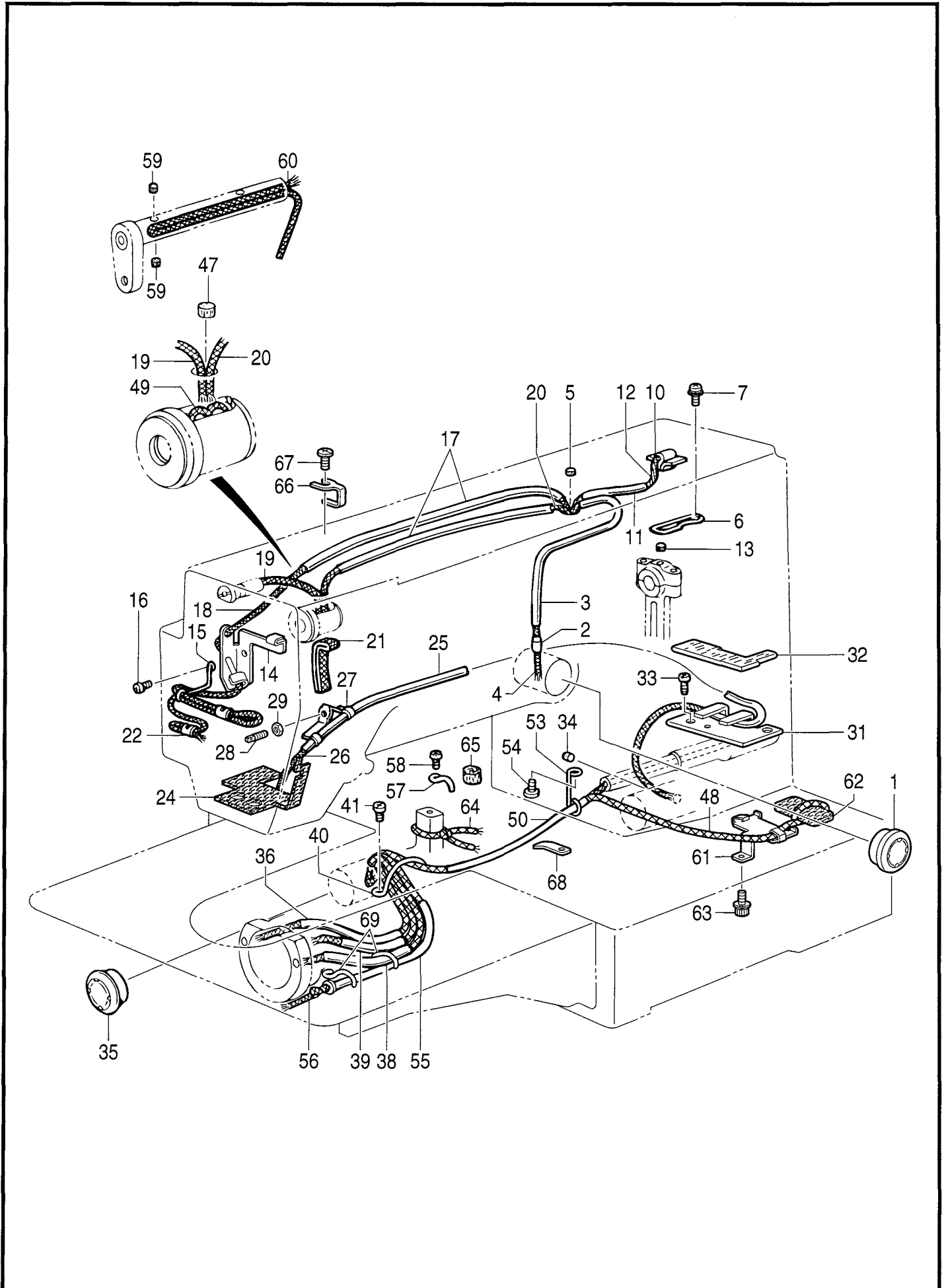

F.給油潤滑関係 / Lubrication

REF.NO	CODE	QTY	品名	NAME OF PARTS	RM
1	S49992000	1	オイルホツトマツ	OIL GAUGE WINDOW	
2	S07333001	1	オイルクチパイプS	OIL FEEDING PIPE, S	
3	S50558000	1	ビニルチューブ	OIL TUBE, L=180	
4	148738000	1	クミヒモ	WICK, L=335	
5	107149001	1	フェルト	FELT	
6	S37983001	1	ウワジクキユウユササエ	WICK SUPPORT	
7	0A5400806	1	+ナベ`サ`クミ4X8DB	SCREW, PAN (S/P WASHER) M4X8	
10	S10478000	1	ロツト`キユウユフェルト	FELT	
11	S34986000	1	ビニルチューブ	OIL TUBE, L=135	
12	S49982000	1	クミヒモ4X4	WICK, 4X4 L=400	
13	107149001	2	フェルト	FELT	
14	S49959001	1	テンピン`キユウユササエ	WICK SUPPORT	
15	S10162201	1	ハリホ`ウヒモササエ	WICK SUPPORT	
16	060670612	1	ハ`イント`357-40X6	SCREW, BIND SM3.57-40X6	
17	S49620000	2	ビニルチューブ	OIL TUBE, L=340	
18	S49957000	1	クミヒモ4X4	WICK, 4X4 L=700	
19	S49622000	1	クミヒモ4X4	WICK, 4X4 L=130	
20	S49983000	1	クミヒモ4X4	WICK, 4X4 L=800	
21	S49984000	1	ヒラクミヒモ	FLAT WICK, L=200	
22	104567101	2	クミヒモササエ	WICK SUPPORT	
24	S42827200	1	スアケ`フェルト	FELT	
25	S46405000	1	ビニルチューブ	OIL TUBE, L=460	
26	S57964000	1	クミヒモ4X4	OIL TUBE, L=1200	
27	145547001	1	チューブ`ホルダ`	TUBE HOLDER	
28	110251001	1	ヌノオサエウテ`ハ`ネカケ	SPRING HOOK	
29	021670102	1	ナツト1シユ3.57	NUT, 1 SM3.57	
31	S55179001	1	シタジ`クキユウユササエ	FELT SUPPORT	
32	S55173000	1	シタジ`クキユウユフェルト	FELT	
33	062680612	1	ナベ`コ4.37-40X6	SCREW, PAN SM4.37-40X6	
34	S09043000	1	フェルト	FELT	
35	152948001	1	オイルホツトマツ	OIL GAUGE WINDOW	
36	S50529000	1	ビニルチューブ	OIL TUBE, L=320	
38	S50529000	1	ビニルチューブ	OIL TUBE, L=320	
39	S49624000	1	ビニルチューブ	OIL TUBE, L=260	
40	S59407001	1	コード`ササエカネ	CORD HOLDER	
41	062670612	3	ナベ`コ357-40X6	SCREW, PAN SM3.57-40X6	
47	153924001	1	フェルト	FELT	
48	S56525000	1	クミヒモ4X4	WICK, 4X4 L=940	
49	S49958000	1	クミヒモ4X4	WICK, 4X4 L=70	
50	SA2382001	1	ビニルチューブ	OIL TUBE, L=305	
53	S49995001	1	コード`ササエカネ	CORD SUPPORT	
54	062670612	1	ナベ`コ357-40X6	SCREW, PAN SM3.57-40X6	
55	S56526000	1	ビニルチューブ	OIL TUBE, L=260	
56	S55659000	1	クミヒモ	WICK, L=300	
57	152969001	1	コード`ササエカネ	CORD HOLDER	
58	062670612	2	ナベ`コ357-40X6	SCREW, PAN SM3.57-40X6	
59	S09043000	2	フェルト	FELT	
60	108802001	1	クミヒモ4X4	WICK, 4X4 L=250	
61	S55180001	1	シタジ`クキ`ヤフェルトササエ	FELT SUPPORT	
62	S55174000	1	シタジ`クキ`ヤフェルト	FELT	
63	S55479001	1	アナホルト`サ`クミ4X8	BOLT, SOCKET (S/P WASHER) M4X8	
64	S17901000	1	クミヒモ4X4	WICK, 4X4 L=460	
65	113006001	1	フェルト	FELT	
66	S57968001	1	キユウユササエ	HOLDER, F	
67	060681212	1	ハ`イント`437-40X12	SCREW, BIND SM4.37-40X12	
68	S59743001	1	チューブ`オサエ	TUBE HOLDER	
69	152969001	2	コード`ササエカネ	CORD HOLDER	

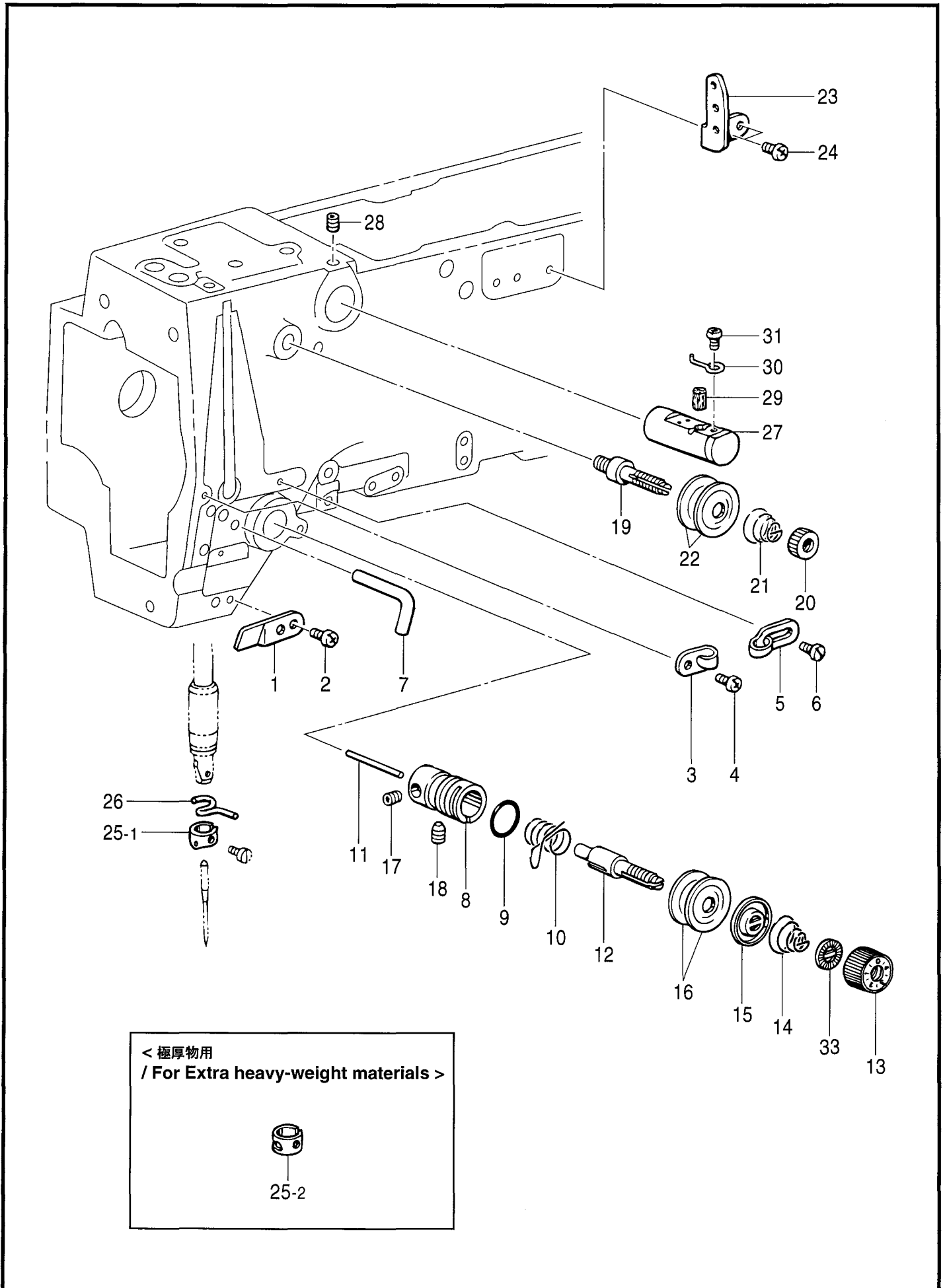

G.系通し関係 / Threading mechanism

REF.NO	CODE	QTY	品名	NAME OF PARTS	RM
1	152869001	1	アームトミチ	ARM THREAD GUIDE	
2	062710612	1	ナベコ476-32X6	SCREW, PAN SM4.76-32X6	
3	152870001	1	アームトカケ	ARM THREAD GUIDE	
4	062670612	1	バインド357-40X6	SCREW, BIND SM3.57-40X6	
5	113316001	1	アームトカケ	ARM THREAD GUIDE	
6	060670612	1	バインド357-40X6	SCREW, BIND SM3.57-40X6	
7	159224001	1	アームトカケ	THREAD GUIDE, ARM	
8	152872001	1	トチヨウシタイ	TENSION BRACKET	
9	114294001	1	リング	O-RING	
			<中厚物用>	<For Medium-weight materials>	
10	145519001	1	トトリハネ	THREAD TAKE-UP SPRING	
			<厚物、極厚物用>	<For Heavy & extra heavy-weight materials >	
10	144588001	1	トトリハネB	THREAD TAKE-UP SPRING, B	
11	S12699000	1	トユルメピン	TENSION RELEASE PIN	
12	116922001	1	トチヨウシホウ	TENSION STUD	
13	S31032001	1	トチヨウシナツ	TENSION NUT	
			<中厚物用>	<For Medium-weight materials>	
14	104525001	1	トチヨウシハネ	TENSION SPRING	
			<厚物用>	<For Heavy-weight materials>	
14	107606001	1	トチヨウシハネ	TENSION SPRING, H	
			<極厚物用>	<For Extra heavy-weight materials>	
14	S06548001	1	トチヨウシハネC	TENSION SPRING, C	
15	159805001	1	トチヨウシサラオサエ	TENSION DISC PRESSER	
16	145446001	2	トチヨウシサラ	TENSION DISC	
17	100402004	1	トメネジ3.57	SET SCREW, SM3.57	
18	S10469001	1	アソメネジ5.95	SET SCREW, SOCKET SM5.95	
19	115186001	1	シュイトチヨウシホウ	MAIN TENSION STUD	
20	100136001	1	トチヨウシナツ	TENSION NUT	
			<中厚物、厚物用>	<For Medium & heavy-weight materials>	
21	SA2900001	1	シュイトチヨウシハネ	TENSION SPRING	
			<極厚物用>	<For Extra heavy-weight materials>	
21	107606001	1	トチヨウシハネ	TENSION SPRING, H	
22	145446001	2	トチヨウシサラ	TENSION DISC	
23	152889001	1	ミツメトカケ	THREAD RETAINER	
24	062670612	2	ナベコ357-40X6	SCREW, PAN SM3.57-40X6	
			<中厚物、厚物用>	<For Medium & heavy-weight materials>	
25-1	S02438001	1	ハリホウイトアンナイA	N-BAR THREAD GUIDE, A	
			<極厚物用>	<For Extra heavy-weight materials>	
25-2	S02439001	1	ハリホウイトアンナイB	N-BAR THREAD GUIDE, B	
26	152891101	1	ハリホウメタルDトアンナイ	N-BAR BUSH THREAD GUIDE, D	
27	152881001	1	エキレイタイグミ	NEEDLE COOLER ASSY	
28	014760632	1	アソクホミ595-28X6	SET SCREW, SOCKET (CP)SM5.95X6	
29	152883000	1	フェルト8X15.5	FELT, 8X15.5	
30	152884001	1	エキレイトカケ	NEEDLE COOLER THREAD GUIDE	
31	062670412	1	ナベコ357-40X4	SCREW, PAN SM3.57-40X4	
33	S12441001	1	チヨウシハネウエザガネ	WASHER	

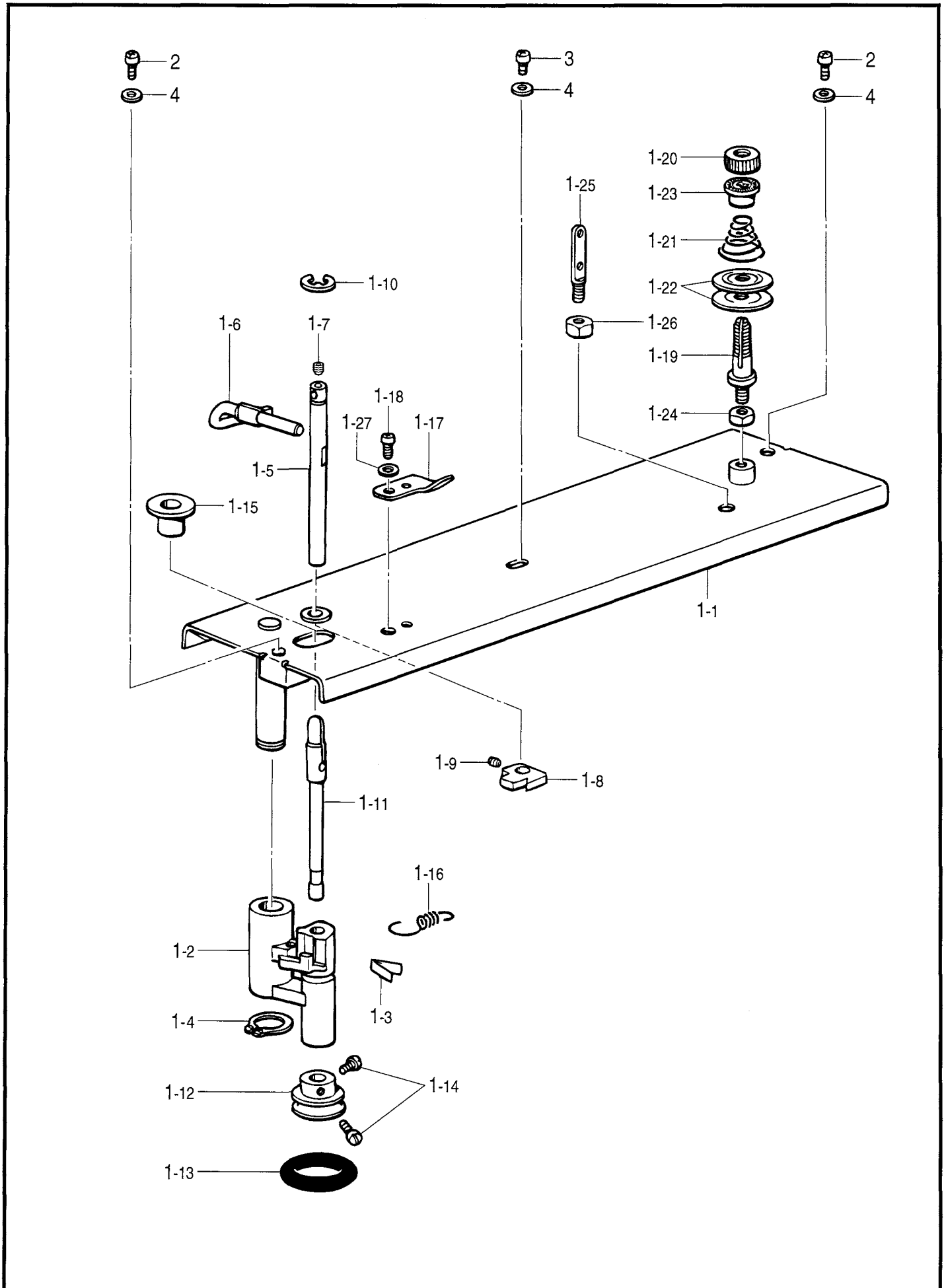

H.糸巻関係 / Bobbin winder mechanism

REF.NO	CODE	Q'TY	品名	NAME OF PARTS	RM
1-1	SA1587001	1	ウワフタクミコ	UPPER COVER SUB ASSY	
1-2	S37992100	1	イトマキウデ	BOBBIN WINDER ARM	
1-3	S37993000	1	イタハネ	PLATE SPRING	
1-4	048100142	1	トメワシクヨウC10	RETAINING RING, EXTERNAL C10	
1-5	S37994001	1	イトマキツメジク	BOBBIN WINDER CLAW STUD	
1-6	S37995101	1	ホビンオサエ	BOBBIN PRESSER	
1-7	100402004	1	トメネジ3.57	SET SCREW, SM3.57	
1-8	S37996001	1	イトマキツメ	BOBBIN WINDER CLAW	
1-9	014680632	1	アナクホミ437-40X6	SET SCREW, SOCKET SM4.37-40X6	
1-10	048050342	1	トメワE5	RETAINING RING, E5	
1-11	S37997001	1	イトマキジク	BOBBIN WINDER SHAFT	
1-12	154528001	1	イトマキクルマ	BOBBIN WINDER WHEEL	
1-13	120448001	1	ゴムワ	RUBBER BAND	
1-14	120990001	2	アタマツキトメネジ4.37	SET SCREW, (CP) SM4.37-40X8	
1-15	S10174000	1	ホコリヨケイタ	DUST GUARD PLATE	
1-16	S37998001	1	イトマキウデハネ	SPRING	
1-17	157968001	1	メス	KNIFE	
1-18	062680512	1	ナベコ437-40X5	SCREW, PAN SM4.37-40X5	
1-19	159574101	1	イトチヨウシホウ	TENSION STUD	
1-20	100136001	1	イトチヨウシナツト	TENSION NUT	
1-21	144110001	1	シタルハイトチヨウシハネ	TENSION ADJUSTING SPRING	
1-22	145446001	2	イトチヨウシサラ	TENSION DISC	
1-23	144105000	1	チヨウシハネウエサガネ	TENSION SPRING FLANGE WASHER	
1-24	021680202	1	ナツト2シユ4.37	NUT, 2 SM4.37	
1-25	141590001	1	イトトオシホウ	THREADING BAR, U	
1-26	100022004	2	ナツト5.95	NUT, SM5.95	
1-27	025680232	1	ヒラサガネチユウ4.37	WASHER, PLAIN M 4.37	
2	062681212	2	ナベコ437-40X12	SCREW, PAN SM4.37-40X12	
3	062680612	1	ナベコ4.37-40X6	SCREW, PAN SM4.37-40X6	
4	025680232	3	ヒラサガネチユウ4.37	WASHER, PLAIN M 4.37	

J. 糸切り関係 / Thread trimmer mechanism

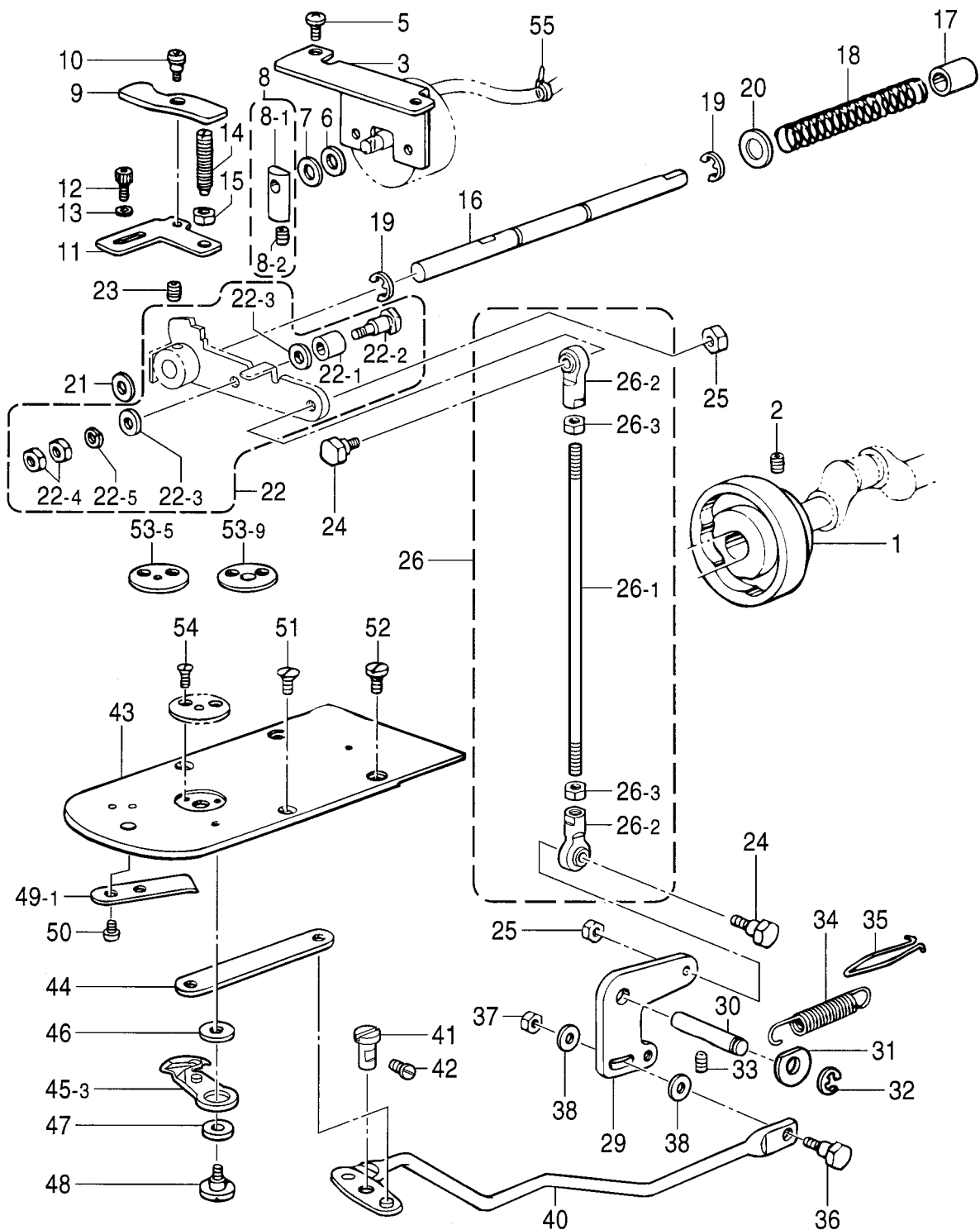

" オプション部品 / OPTION PARTS "

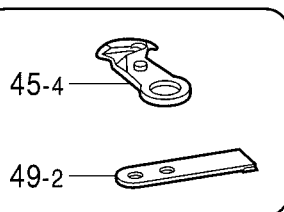

J.糸切り関係 / Thread trimmer mechanism

REF.NO	CODE	QTY	品名	NAME OF PARTS	RM
1	SA2902001	1	イトキリカム	THREAD TRIMMER CAM	
2	014770632	2	アナクホミ635-40X6	SET SCREW, SOCKET(CP) SM6.35X6	
3	S38002301	1	ソレノイドトリツケイタ	SOLENOID SETTING PLATE	
5	060681212	2	バインド437-40X12	SCREW, BIND SM4.37-40X12	
6	154599000	1	ソレノイドクッション	SOLENOID CUSHION	
7	S02652001	1	ザガネ	WASHER	
8	S23836001	1	ソレノイドレバークミ	SOLENOID LEVER ASSY	
8-1	S02654001	1	ソレノイドレバー	SOLENOID LEVER	
8-2	014680632	1	アナクホミ437-40X6	SET SCREW, SOCKET (CP) SM4.37	
9	SA2901001	1	クトウレバ-オシレバ-	DRIVING LEVER PUSH LEVER	
10	145478101	1	ダンネジ4.76	SHOULDER SCREW, SM4.76	
11	S38004002	1	クトウレバ-ストツパ(記号2)	DRIVING LEVER STOPPER (Mark 2)	
11	S38004003	1	クトウレバ-ストツパ(記号3)	DRIVING LEVER STOPPER (Mark 3)	
11	S38004004	1	クトウレバ-ストツパ(記号4)	DRIVING LEVER STOPPER (Mark 4)	
12	S59893001	2	アナホルルト437-40X10	BOLT, SOCKET SM4.37-40X10	
13	148847001	2	ザガネ	WASHER, PLAIN 4.76	
14	159905001	1	トメヌイチヨウセツネジ	ADJUSTING SCREW	
15	105812003	1	ナツト7.94	NUT, SM7.94	
16	S38005001	1	クトウレバ-アンナイズク	DRIVING LEVER GUIDE SHAFT	
17	231071001	1	メタル8X15	BUSH, 8X15	
18	S32235001	1	ヌノオサエハネ	SPRING, COMPRESSION	
19	048070342	2	トメワE7	RETAINING RING, E7	
20	153596001	1	ザガネ	WASHER	
21	154596000	1	イトキリカムレバークッション	CUSHION	
22	SA2904001	1	イトキリクトウレバークミ	THREAD DRIVING LEVER ASSY	
22-1	S59872001	1	イトキリコロ	THREAD TRIMMER ROLLER	
22-2	S59871001	1	ダンネジ4.37	SHOULDER SCREW, SM4.37	
22-3	S59873001	2	ザガネ	WASHER, PLAIN	
22-4	SA0049001	2	ナツト4.37	NUT, SM4.37	
22-5	028680242	1	ハネザガネ2-4.37	WASHER, SPRING 2-4.37	
23	014770632	1	アナクホミ635-40X6	SET SCREW, SOCKET(CP) SM6.35X6	
24	S02354001	2	タマツキテダンネジB	SHOULDER SCREW, B	
25	100022005	2	ナツト5.95	NUT, SM5.95	
26	S55177001	1	イトキリロツト`Sクミ	THREAD TRIMMER ROD ASSY, S	
26-1	S55178001	1	イトキリロツト`S	THREAD TRIMMER ROD	
26-2	141492001	2	タマツキテクミ	JOINT ASSY	
26-3	100022005	2	ナツト5.95	NUT, SM5.95	
29	S49650001	1	イトキリレバ-	THREAD TRIMMER LEVER	
30	S10195101	1	イトキリレバ-ジク	THREAD TRIMMER LEVER SHAFT	
31	110367001	1	ザガネ	WASHER, PLAIN SPECIAL 8	
32	048060342	1	トメワE6	RETAINING RING, E6	
33	014760632	1	アナクホミ595-28X6	SET SCREW, SOCKET SM5.95-28X6	
34	S38011001	1	イトキリモツシハネ	EXTENSION LEVER	
35	S49651001	1	ハネカケ	SPRING HOOK	
36	110233001	1	ダンネジ4.76	SHOULDER SCREW, SM4.76	
37	110161004	1	ナツト4.76	NUT, SM4.76	
38	S49994001	2	ザガネ4.76	WASHER, PLAIN 4.76	
40	S42856001	1	レンカンレバークミ	CONNECTING ROD LEVER ASSY	
41	S10202201	1	レンカンレバ-ジク	LEVER SHAFT	
42	121007001	1	アタマツキトメネジ4.37	SET SCREW, SM4.37	
			<311F-0, 311F-L用>	<For 311F-0 & 311F-L>	
43	S10203201	1	ハリイタ	NEEDLE PLATE	
			<326F-0用>	<For 326F-0>	
43	S11438101	1	ハリイタ	NEEDLE PLATE	

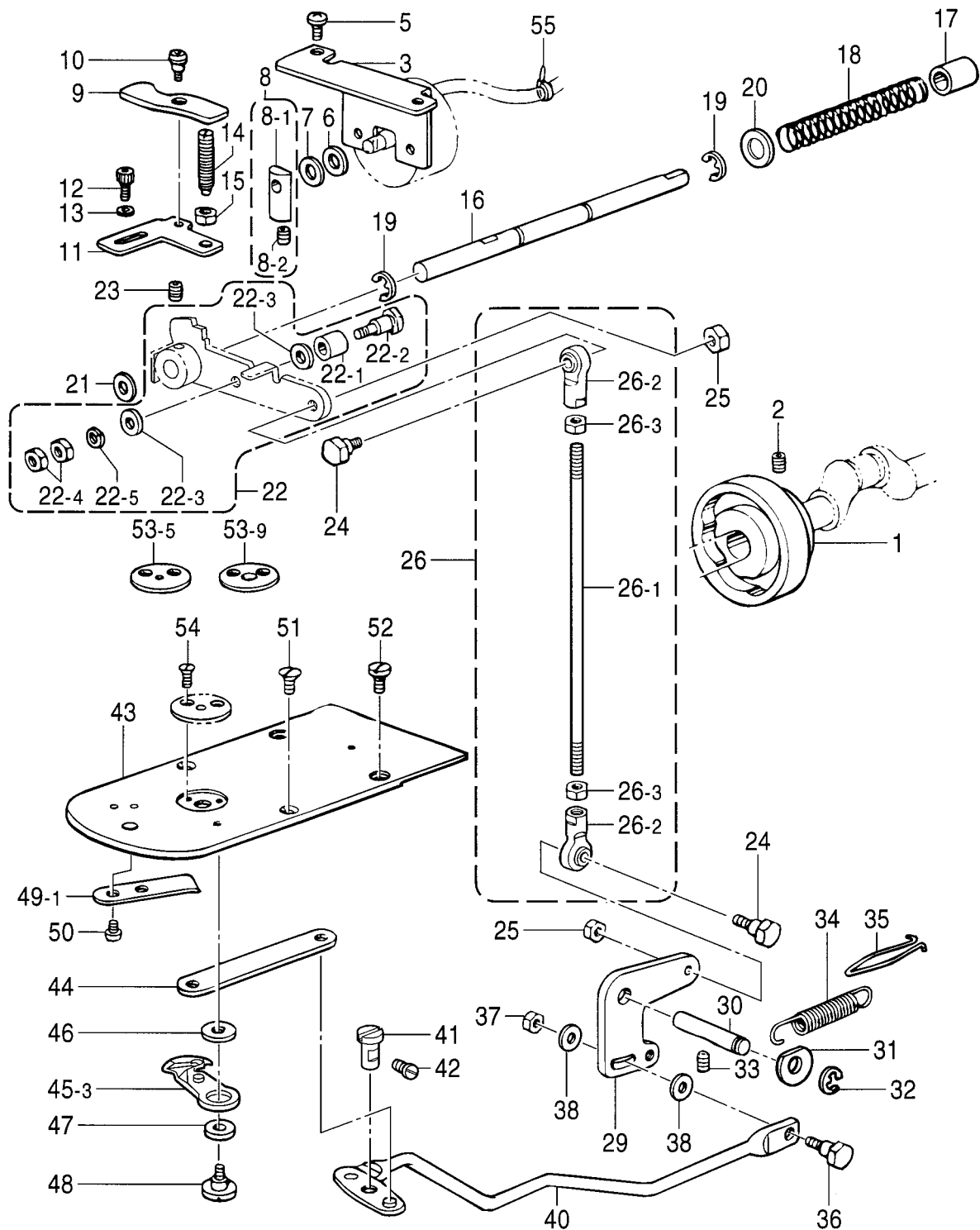

" オプション部品 / OPTION PARTS "



J.糸切り関係 / Thread trimmer mechanism

REF.NO	CODE	Q'TY	品名	NAME OF PARTS	RM
44	S10204101	1	イトキリレンカン	THREAD TRIMMER CONNECTING ROD	
45-3	SA2907001	1	イトウハノクミ	MOVABLE KNIFE ASSY, N	
46	S10208001	1	イトウハカンサ [*] (t=0.4)	MOVABLE KNIFE SPACER (t=0.4)	
46	S10208002	1	イトウハカンサ [*] (t=0.5)	MOVABLE KNIFE SPACER (t=0.5)	
46	S10208003	1	イトウハカンサ [*] (t=0.6)	MOVABLE KNIFE SPACER (t=0.6)	
46	S10208004	1	イトウハカンサ [*] (t=0.7)	MOVABLE KNIFE SPACER (t=0.7)	
47	S00705001	1	イトウハカラー	MOVABLE KNIFE COLLAR	
48	S10209101	1	シメネジ [*] 4.37	SCREW, SM4.37	
49-1	S10210201	1	コテイハ	FIXED KNIFE	
50	111140002	2	シメネジ [*] 2.38	SCREW, SM2.38	
51	100032004	2	サラネジ [*] 4.37	SCREW, FLAT SM4.37-40X8	
52	S11244001	2	シメネジ [*] 4.37		
			<中厚物、厚物用>	<For Medium & heavy-weight materials>	
53-5	S10213001	1	ハリアナイタF (φ 2.2)	NEEDLE HOLE PLATE, F (φ 2.2)	
			<極厚物用>	<For Extra heavy-weight materials>	
53-9	S34348001	1	ハリアナイタM (φ 4.0)	NEEDLE HOLE PLATE, M (φ 4.0)	
54	100360003	2	サラネジ [*] 2.38	SCREW, FLAT SM2.38	
55	228475000	2	ケツソクバンド [*] 1.9X80	CABLE TIE, 1.9X80	
			"オプション部品"	"OPTION PARTS"	
45-1	S10205001	1	イトウハクミ	MOVABLE KNIFE ASSY	
45-2	S40934101	1	イトウハクミ	MOVABLE KNIFE ASSY, L	
			<ケブラー糸用>	<For Kevlar thread>	
45-4	S31612001	1	イトウハチヨウコウクミ	MOVABLE KNIFE ASSY, H/MATERIAL	
49-2	S30128001	1	コテイハチヨウコウ	FIXED KNIFE, HARD MATERIAL	
53-1	S10211001	1	ハリアナイタA (φ 1.6)	NEEDLE HOLE PLATE, A (φ 1.6)	
53-2	S29997001	1	ハリアナイタD (φ 2.6)	NEEDLE HOLE PLATE, D (φ 2.6)	
53-3	S10212101	1	ハリアナイタE	NEEDLE HOLE PLATE, E	
53-4	S30925001	1	ハリアナイタED (φ 3.4)	NEEDLE HOLE PLATE, ED (φ 3.4)	
53-6	S30926001	1	ハリアナイタFD (φ 2.2)	NEEDLE HOLE PLATE, FD (φ 2.2)	
53-7	S30450001	1	ハリアナイタH (φ 2.6)	NEEDLE HOLE PLATE, H (φ 2.6)	
53-8	S25127001	1	ハリアナイタL (φ 3.3)	NEEDLE HOLE PLATE, L (φ 3.3)	
53-10	S49980001	1	ハリアナイタFM (φ 2.2)	NEEDLE HOLE PLATE, FM (φ 2.2)	
53-11	S40217001	1	ハリアナイタ3サ [*] ガ [*] リ (φ 3.3)	NEEDLE HOLE PLATE, 3 (φ 3.3)	
53-12	S51449001	1	ハリアナイタA-F (φ 1.6)	NEEDLE HOLE PLATE, A-F (φ 1.6)	

K. 糸払い関係 / Thread wiper mechanism

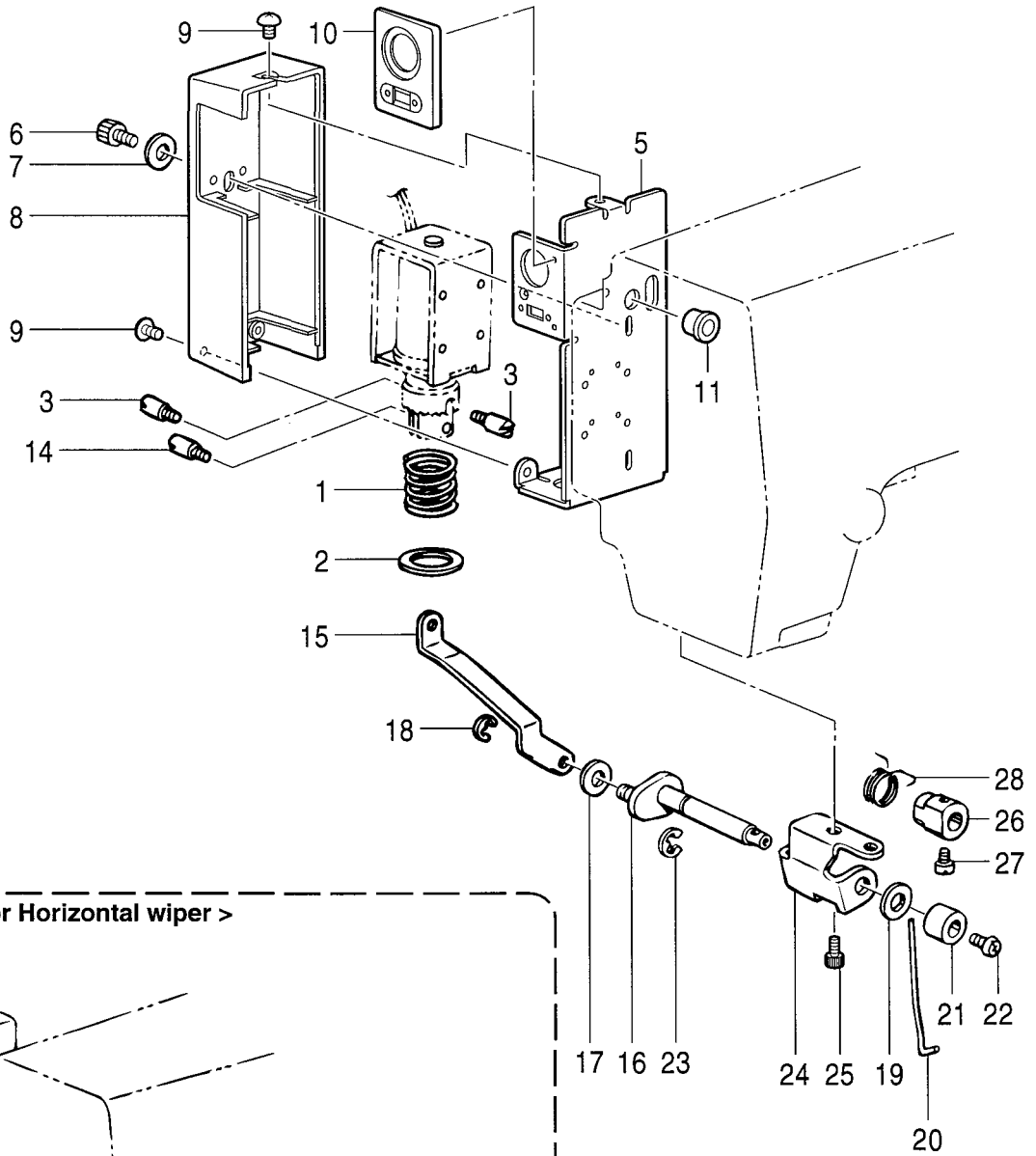

< 横払いワイパー用 / For Horizontal wiper >

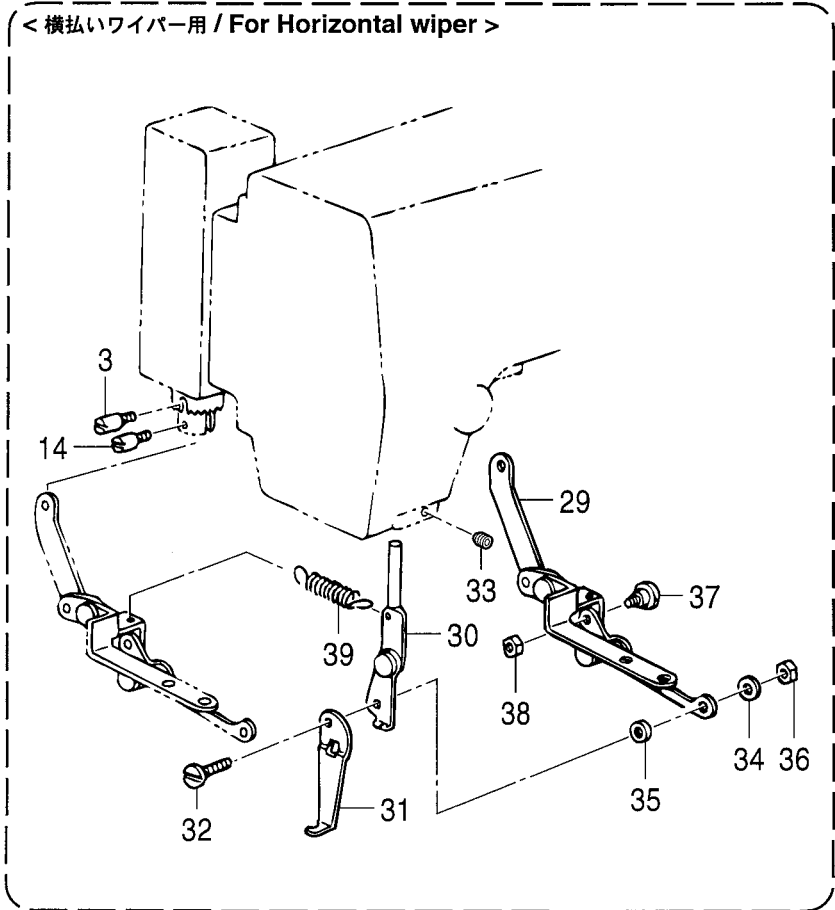

K.糸払い関係 / Thread wiper mechanism

REF.NO	CODE	QTY	品名	NAME OF PARTS	RM
1	S41206001	1	イトハライハネ	THREAD WIPER SPRING	
2	S41205001	1	ヒラサガネ	WASHER, PLAIN	
3	S25456001	2	プランジヤピン	PLUNGER PIN	
5	S55149100	1	イトハライSOLトリツケイタ	T-WIPER SOLENOID SETTING PLATE	
6	S59893001	2	アナホルト437-40X10	BOLT, SOCKET SM4.37-40X10	
7	100645003	2	サガネ	WASHER	
8	S55150000	1	イトハライSOLカバー	THREAD WIPER SOLENOID COVER	
9	S55151000	3	トラスコ4X6	SCREW, TRUSS M4X6	
10	S55133000	1	イトハライSOLカバーフタ	SOLENOID COVER LID	
11	S38059000	1	グロメットNG79F	RUBBER CAP, NG79F	
14	S25456001	1	プランジヤピン	PLUNGER PIN	
15	S42858001	1	イトハライレソカン	THREAD WIPER CONNECTING ROD	
16	S10217101	1	イトハライクランクミ	THREAD WIPER CRANK ASSY	
17	110735001	1	サガネ	WASHER	
18	048030342	1	トメE3	RETAINING RING, E3	
19	025750132	1	ヒラサガネシヨウ5.56	WASHER, PLAIN S 5.56	
20	S10470101	1	ワイパー	WIPER	
21	146288001	1	イトハラシヅクカラー	THREAD WIPER STUD COLLAR	
22	060680512	1	バインド437-40X5	SCREW, BIND SM4.37-40X5	
23	048040342	1	トメE4	RETAINING RING, E4	
24	S55148002	1	イトハラシヅクウケイタ	THREAD WIPER SUPPORT	
25	S59891001	2	アナホルト437-40X6	BOLT, SOCKET SM4.37-40X6	
26	S02677001	1	セットカラー	SET SCREW COLLAR	
27	144458001	1	アタマツキトメネジ3.57	SET SCREW, SM3.57-40X4.5	
28	S02678001	1	ワイパーハネ	WIPER SPRING	
			<横払いワイパー用>	<For Horizontal wiper>	
29	S42859001	1	イトハライレソカンヨコミ	T-WIPER CONNECTING ROD ASSY	
30	S42864101	1	ワイパーウテギミ	WIPER ARM ASSY	
31	156206001	1	ワイパーA	THREAD WIPER, A	
32	S13385001	1	シメネジ3.57X10	SCREW, SM3.57-40X10	
33	014760632	1	アナホルミ595-28X6	SET SCREW, SOCKET (CP)SM5.95X6	
34	S21875001	1	サガネ	WASHER	
35	S12668001	1	カラー	COLLAR	
36	021670202	1	ナット2シユ3.57	NUT, 2 SM3.57	
37	100659001	1	ダンネシ3.18	SHOULDER SCREW, SM3.18	
38	021660102	1	ナット1シユ3.18	NUT, 1 SM3.18	
39	159111001	1	Cクラツチアンナイハネ	C CLUTCH GUIDE SPRING	

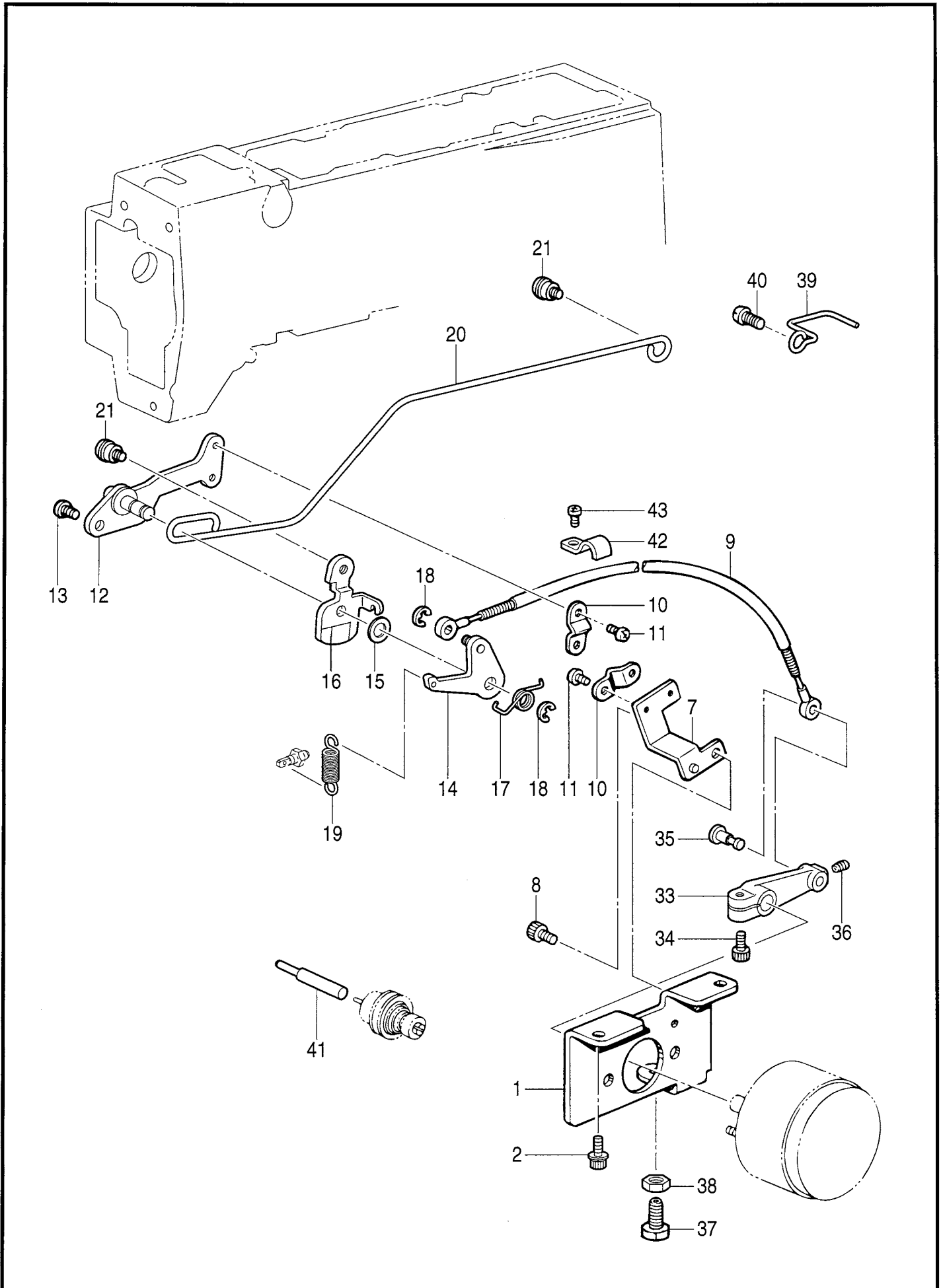

L.糸締め関係 / Thread nipper mechanism

REF.NO	CODE	Q'TY	品名	NAME OF PARTS	RM
1	S10219001	1	ソレノイドトリツケイタ	SOLENOID SETTING PLATE	
2	S42446001	2	アナホルトサクミ6X14	BOLT, SOCKET (S/P WASHER)M6X14	
7	S10221001	1	ワイヤササエ	WIRE SUPPORT	
8	018060832	1	アナホルト6X8	BOLT, SOCKET M6X8	
9	S42868001	1	オサエアケワイヤクミ	W-CLAMP LIFTER WIRE ASSY	
10	154607101	2	イトユルメワイヤ-オサエD	WIRE HOLDER, D	
11	062670612	4	ナベコ357-40X6	SCREW, PAN SM3.57-40X6	
12	S42870201	1	イトユルメブラケット	TENSION RELEASE BRACKET	
13	062771012	1	ナベコ635-40X10	SCREW, PAN SM6.35-40X10	
14	S42871201	1	オサエアシアケレバークミ	WORK CLAMP LIFTER LEVER ASSY	
15	109763002	1	サカネ	WASHER	
16	S42873101	1	イトユルメレバー	T-RELEASE LEVER	
17	S10229101	1	オサエレバーハネ	SPRING	
18	048040342	3	トメワE4	RETAINING RING, E4	
19	S55137001	1	カンケツモトシハネ	SPRING, EXTENSION 8.6X30.2	
20	SA2903001	1	イトユルメロッド	TENSION RELEASE ROD ASSY, SF	
21	145478101	2	ダンネシ4.76	SHOULDER SCREW, SOCKET SM4.76	
33	S10230000	1	オサエアケレバー	LIFTER LEVER, P-BAR	
34	018501432	1	アナホルト5X14	BOLT, SOCKET M5X14	
35	S10231001	1	ケーブルエンドピン	CABLE & PIN	
36	014680632	1	アナクホミ437-40X6	SET SCREW, SOCKET SM4.37-40X6	
37	017822212	1	ホルト7.94X22	BOLT, SM7.94X22	
38	106147002	1	ナット7.94	NUT, SM7.94	
39	S10232001	1	ケーブルササエ	CABLE SUPPORT	
40	062760812	1	ナベコ595-28X8	SCREW, PAN SM5.95-28X8	
41	S55199001	1	イトユルメピンL	TENSION RELEASE PIN, L	
42	140647101	1	コードオサエ	CORD HOLDER	
43	062670612	1	ナベコ357-40X6	SCREW, PAN SM3.57-40X6	

M1 . 糸取り関係 (311F-0, 311F-L用オプション部品) /
 Thread take-up mechanism (Option parts of 311F-0 & 311F-L)

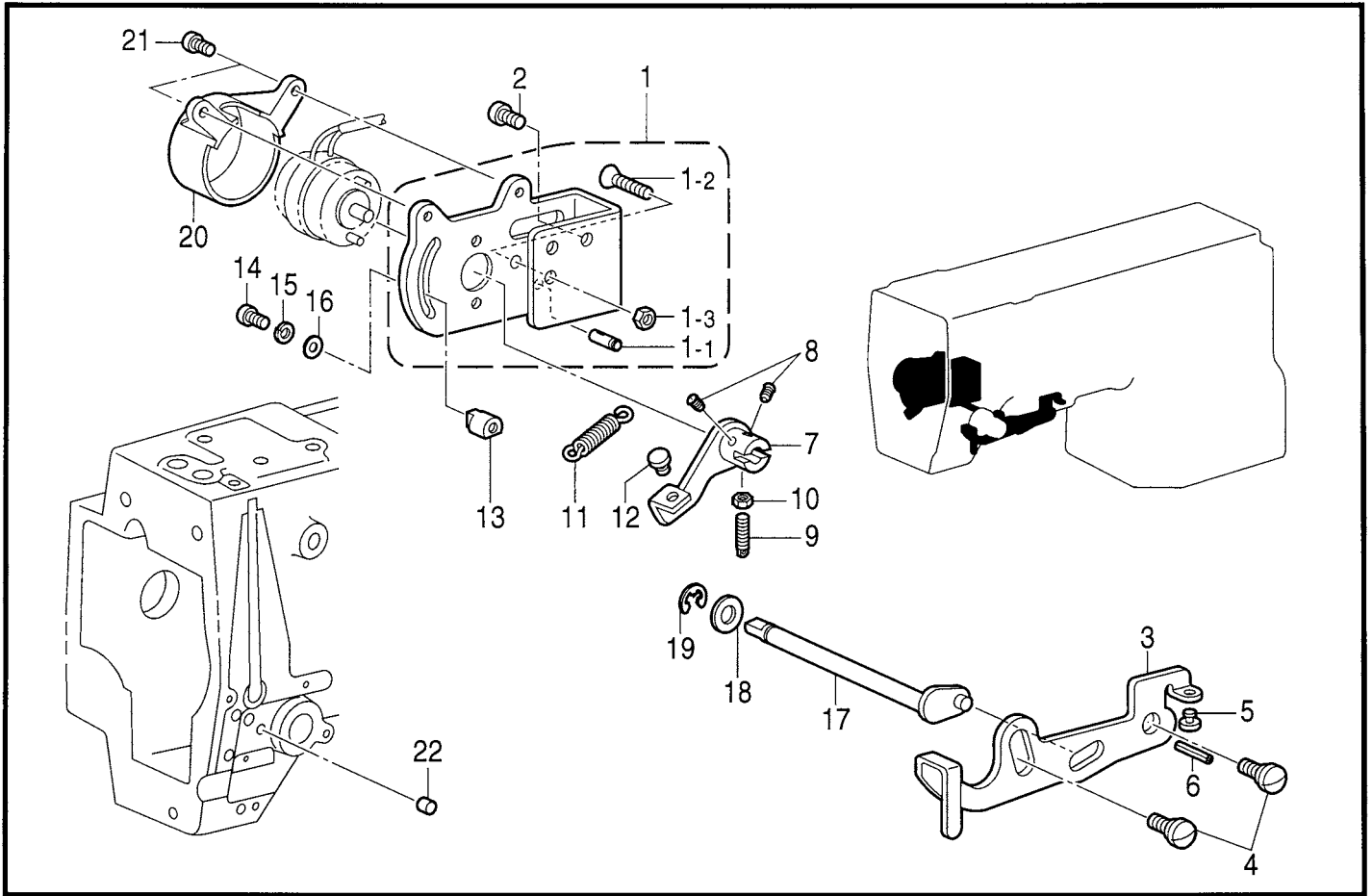

BAS-311F-0-408

M2 . 糸取り関係 (326F-0用オプション部品) /
 Thread take-up mechanism (Option parts of 326F-0)

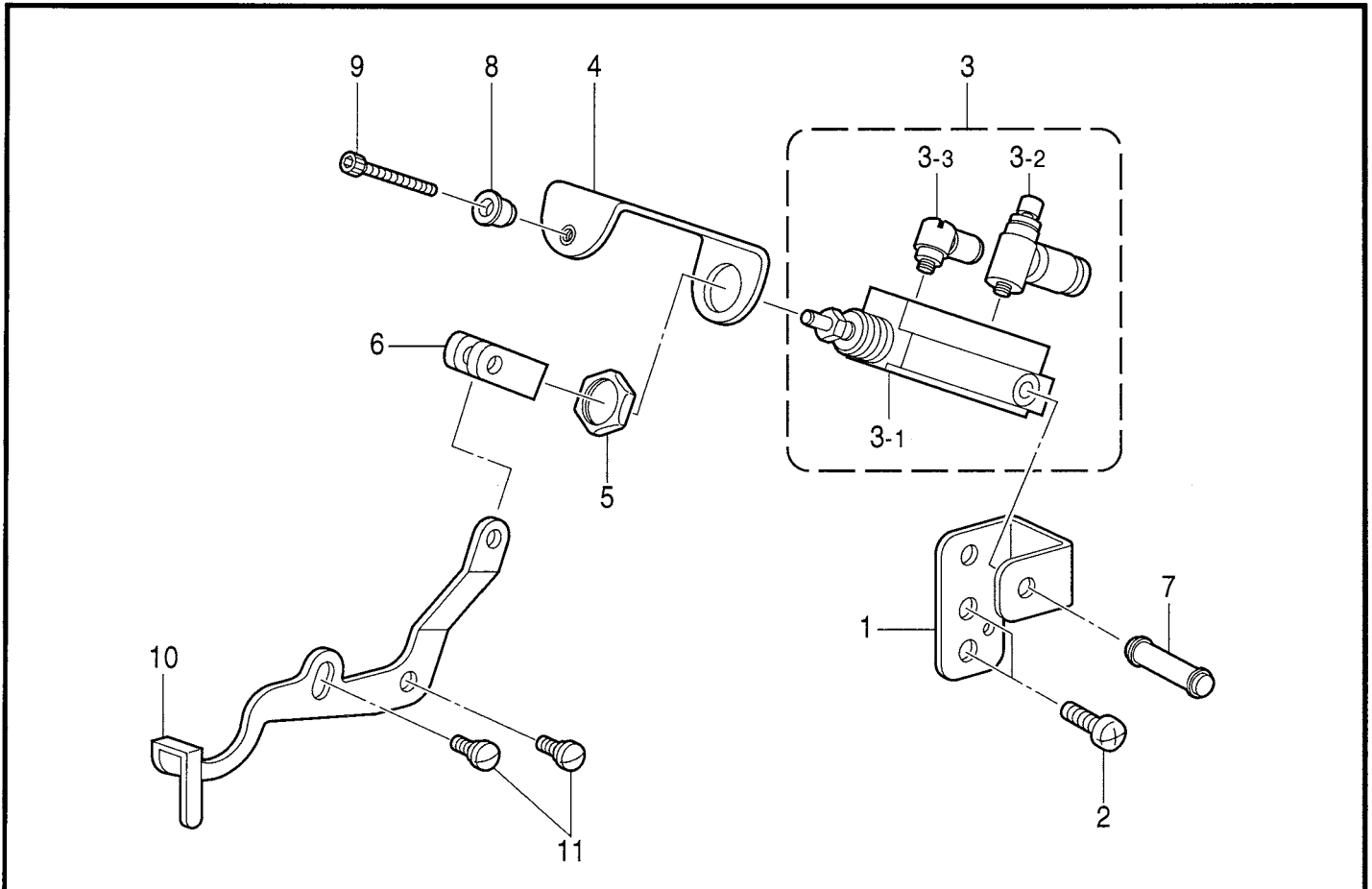

BAS-326F-0-408

M1.系取り関係 (311F-0, 311F-L用オプション部品) /

Thread take-up mechanism (Option parts of 311F-0 & 311F-L)

REF.NO	CODE	Q'TY	品名	NAME OF PARTS	RM
1	S55181001	1	ソレノイドトリツケイタ	SOLENOID SETTING PLATE ASSY	
1-1	S55183000	1	ミゾツキピンBX4X12	PIN, DOWEL BX4X12	
1-2	004063014	1	サコ6X30	SCREW, FLAT M6X30	
1-3	021060106	1	1シユナツト	NUT, 1 M6	
2	062710812	2	ナベコ476-32X8	SCREW, PAN SM4.76-32X8	
3	S49660101	1	イトトリレバ	THREAD TAKE-UP LEVER	
4	107321003	2	ダンネジ 4.76	SHOULDER SCREW, SM4.76	
5	S19748001	1	サトウクランククツシヨ	CUSHION	
6	047401442	1	スプリングピンAW4	PIN, SPRING ROLL AW4	
7	S49661101	1	ソレノイドツキテ	SOLENOID JOINT	
8	S01998001	2	アタマツキトメネジ 3.57	SET SCREW, SM3.57-40X6	
9	110251001	1	スプリングフック	SPRING HOOK	
10	021670102	1	ナツト1シユ3.57	NUT, 1 SM3.57	
11	S34883001	1	イトキリハネ	SPRING, EXTENSION	
12	S19748001	1	サトウクランククツシヨ	CUSHION	
13	S49663001	1	ナツト3.57	NUT, SM3.57	
14	062671012	1	ナベコ357-40X10	SCREW, PAN SM3.57-40X10	
15	028350242	1	ハネサガネ2-3.5	WASHER, SPRING 2-3.5	
16	025350332	1	ヒラサガネ13.5	WASHER, PLAIN L 3.5	
17	S55111001	1	イトトリレバークランク	THREAD TAKE-UP LEVER CRANK	
18	155559001	1	ヒラサガネ	WASHER, PLAIN	
19	048040342	1	トマエE4	RETAINING RING, E4	
20	S49664000	1	イトトリソレノイドカバー	THREAD TAKE-UP SOLENOID COVER	
21	062670612	2	ナベコ357-40X6	SCREW, PAN SM3.57-40X6	
22	S20878000	1	ゴムセン5.3	RUBBER CAP, 5.3	

BAS-311F-0-408

M2.系取り関係 (326F-0用オプション部品) /

Thread take-up mechanism (Option parts of 326F-0)

REF.NO	CODE	Q'TY	品名	NAME OF PARTS	RM
1	S56531001	1	シリンダトリツケイタ	SETTING PLATE	
2	062710812	2	ナベコ476-32X8	SCREW, PAN SM4.76-32X8	
3	S50052000	1	ピンシリンダ	PIN CYLINDER ASSY	
3-1	S50048000	1	ピンシリンダ	PIN CYLINDER	
3-2	S23660000	1	スピードコントローラ	SPEED CONTROLLER	
3-3	S12150000	1	ホースエルボ M-5HL-4	TUBE ELBOW, M-5HL-4	
4	S56532001	1	ストップラケット	STOPPER BRACKET	
5	S50051000	1	ナツトM12	NUT, M12	
6	S50050000	1	フタヤマナツクル	KNUCKLE	
7	S50049000	1	トラニオンピン	PIN	
8	S32259001	1	プレテンションナツト	PRE-TENSION NUT	
9	018401636	1	アホルト4X16	BOLT, SOCKET M4X16	
10	S56533101	1	イトトリレバ	LEVER	
11	107321003	2	ダンネジ 4.76	SHOULDER SCREW, SM4.76	

BAS-326F-0-408

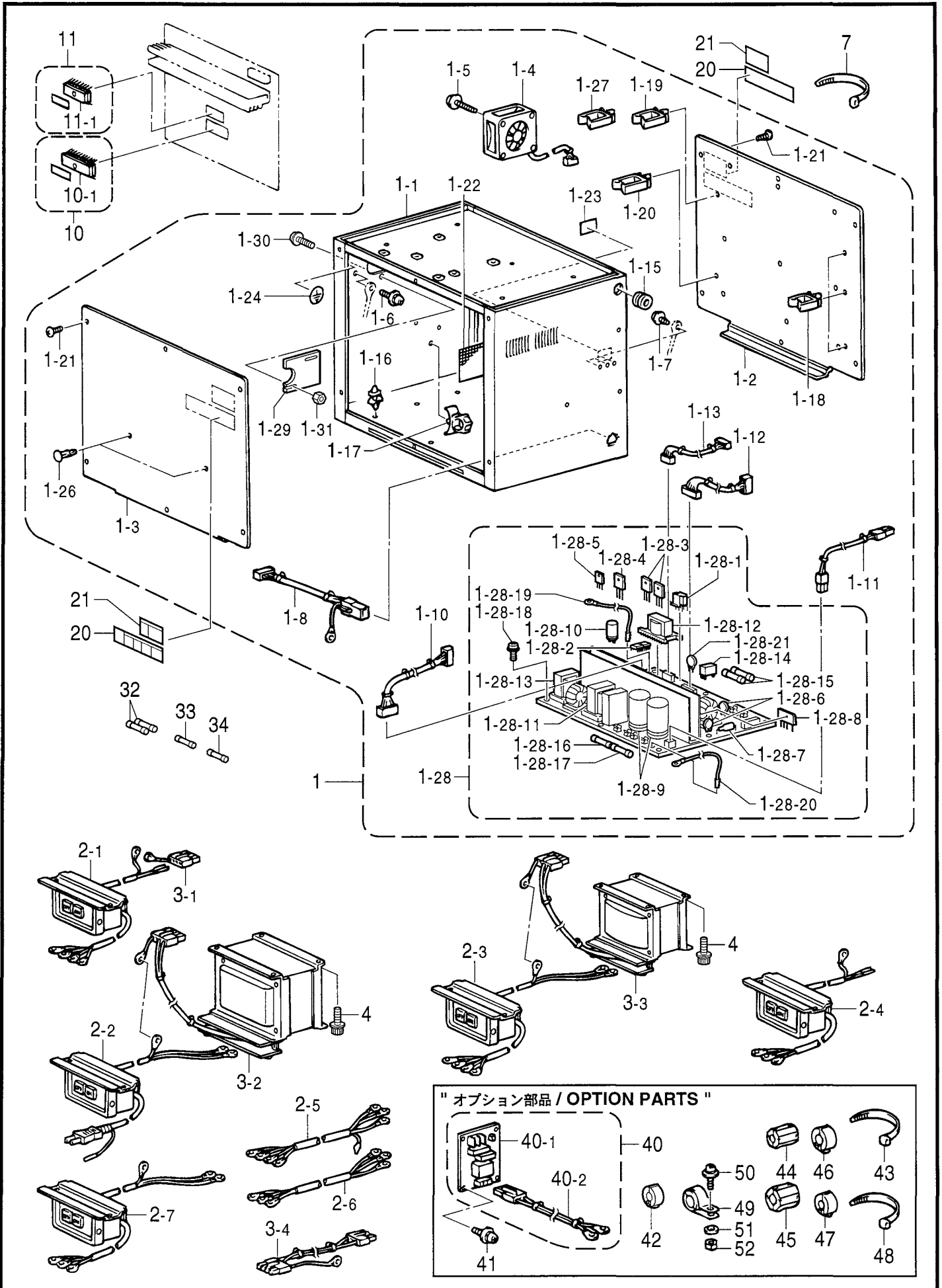

N.コントロールボックス関係 / Control box mechanism

REF.NO	CODE	Q'TY	品名	NAME OF PARTS	RM
1	S56154101	1	ボックスミ	CONTROL BOX ASSY	
1-1	S43170109	1	デンケンボックス	POWER SUPPLY BOX	
1-2	S43171009	1	キバントリツケイタ	SETTING PLATE, PCB	
1-3	S43172009	1	ボックスフタ	BOX COVER	
1-4	S38094100	2	DCファンモータミ	DC-FAN MOTOR ASSY	
1-5	0A5403006	6	+ナヘサクミ4X30DB	SCREW, PAN (S/P WASHER) M4X30	
1-6	0A5400806	1	+ナヘサクミ4X8DB	SCREW, PAN (S/P WASHER) M4X8	
1-7	0A5401006	3	ナヘコハネヒラ4X10	SCREW, PAN (S/P WASHER) M4X10	
1-8	S42260000	1	フットSWコート434クミ	FOOT SWITCH HARNESS ASSY, 434	
1-10	S38107100	1	セイキヨデンケンコート	CONTROL POWER SUPPLY HARNESS	
1-11	S38108000	1	モータデンケンコート	MOTOR POWER SUPPLY HARNESS	
1-12	S38109100	1	ゲートデンケンコート	H-P POWER SUPPLY HARNESS	
1-13	S38110000	1	PERコート	POWER HARNESS	
1-15	S43186000	1	ブツシユBU687B	BUSH, BU687B	
1-16	S00554000	18	サポート6NS	SUPPORT, 6NS	
1-17	S31760000	1	CKSクランプ26L	CORD CLAMP, 26-L	
1-18	S43275000	7	コートクランプWS2NS	CORD CLAMP, WS2NS	
1-19	S43276000	1	コートクランプWS3NS	CORD CLAMP, WS3NS	
1-20	S43277000	1	コートクランプWS4NS	CORD CLAMP, WS4NS	
1-21	008400604	12	トラスコ4X6	SCREW, TRUSS M4X6	
1-22	S43309000	1	ボウジンアミ	FRAGMENT PROTECTOR NET	
1-23	S37059001	1	PEマーク	LABEL, PE	
1-24	S37060001	1	アースマーク	LABEL, GROUNDING	
1-26	S34413000	2	スペーサー	SPACER	
1-27	S43318000	2	クランプLW8S2.5W	CLAMP, LWS8S 2.5W	
1-28	S49939101	1	デンケンキバシキミ	POWER SUPPLY PCB ASSY	
1-28-1	S43177000	1	MA3830クミ	IC :MA3830	
1-28-2	S43184000	2	PHカプラPC923	PHOTO COUPLER :PC923	
1-28-3	S49586000	2	MOSFET2SK1941	TRANSISTOR, FET :2SK1941	
1-28-4	S47668000	1	SIDPA905C6	DIODE, AR :PA905C6	
1-28-5	S38203000	1	SBDYG802C04R	DIODE :YG8022C04R	
1-28-6	SA0037000	2	バリスタV14D511	VARIATOR:V14D511	
1-28-7	232384001	1	SアブソバDSA362MA	SURGE ABSORBER :DSA362MA	
1-28-8	S49071000	1	DBRD25XB60	DIODE BRIDGE :25XB60	
1-28-9	S38205000	2	デンC250B182	CAPACITOR, ALUM-ELEC 250B182	
1-28-10	SA1034000	1	デンC63B562	CAPACITOR, ALUM-ELEC 63B562	
1-28-11	S43175000	1	トランスETS54AA159	TRANSFORMER :54AA159	
1-28-12	S43176000	1	トランスETS35AD199	TRANSFORMER :35AD199	
1-28-13	S43181000	1	コイルETS49AD289AC	COIL :49AD289AC	
1-28-14	S38208000	1	RYJW1AFSND5V	RELAY :JW1AFSN/DC 5V	
1-28-15	153242000	2	ヒューズ6A	FUSE, 6A	
1-28-16	S08030000	1	Gヒューズ5AFB	FUSE, 5A :FB	
1-28-17	S48580000	1	GFUSE7AFB	FUSE, 7A :FB	
1-28-18	0A4301005	8	+ナヘサクミ3X10DA	SCREW, PAN (S/P WASHER) M3X10	
1-28-19	S43189000	1	PCBE1コート	PCB E1 HARNESS	
1-28-20	S43187000	1	PCBE2コート	PCB E2 HARNESS	
1-28-21	S49472000	1	サーミスタ6D-22	THERMISTOR :6D-22	
1-29	S38093000	1	コートオサエイタ	HOLDER PLATE	
1-30	0A5401206	2	+ナヘサクミ4X12DB	SCREW, PAN (S/P WASHER) M4X12	
1-31	021400206	2	シユナツト4	NUT, 2 M4	

BAS-311F-0-502

☆RM欄に※が付いている部品をご注文頂きますと、基板等必要な部品が一式入ったセットになっております。

☆When ordering parts which have an asterisk(※) in the RM column, these parts will be supplied as a set together with other necessary parts such as circuit boards.

N.コントロールボックス関係 / Control box mechanism

REF.NO	CODE	Q'TY	品名	NAME OF PARTS	RM
2-1	S38112001	1	<三相200V, 220V用> デンゲンSWクミA	<For "3-phase 200V-220V AC"> POWER SUPPLY SWITCH ASSY, A	
2-2	S38114000	1	<単相100V用> デンゲンSWクミB	<For Japan only> POWER SUPPLY SWITCH ASSY, B	
2-3	S38117000	1	<三相380V用> デンゲンSWクミC	<For "3-phase 380V AC"> POWER SUPPLY SWITCH ASSY, C	
2-4	S47592000	1	<単相220V用> デンゲンSWクミD	<For "1-phase 220V AC"> POWER SUPPLY SWITCH ASSY, D	
2-5	S38120000	1	<三相400V用> デンゲンINコードE	<For "3-phase 400V AC"> POWER SUPPLY IN HARNESS, E	
2-6	S43188000	1	<単相230V用> デンゲンINコードF	<For "1-phase 230V AC"> POWER SUPPLY IN HARNESS, F	
2-7	S47594000	1	<単相110V, 240V用> デンゲンSWクミG	<For "1-phase 110V-240V AC"> POWER SUPPLY SWITCH ASSY, G	
3-1	S38123000	1	<200V, 220V用> ACINコネクタクミ	<For "200V & 220V AC"> AC-IN CONNECTOR ASSY	
3-2	S43369000	1	<100V, 110V用> ヘンカトランスBクミ	<For "100V & 110V AC"> CONVERSION TRANSFORMER ASSY, B	
3-3	S43370000	1	<240V, 380V, 400V用> ヘンカトランスCクミ	<For "240V, 380V & 400V AC"> CONVERSION TRANSFORMER ASSY, C	
3-4	S43201000	1	<単相230V用> ACINコードF	<For "1-phase 230V AC"> AC-IN HARNESS, F	
4	S55476002	4	アナボルトサクミ6X12	BOLT, SOCKET (S/P WASHER)M6X12	
7	228475000	1	ケツクバンド1.9X80	CABLE TIE, 1.9X80	
10	S53889000	1	PROMセイキヨクミ	PROM ASSY, CONTROL	
10-1	UA4817000	1	MOSLSI27C2001	EPROM:27C2001	
11	S53890000	1	PROMモータクミ	PROM ASSY, MOTOR	
11-1	U85274000	1	LSIM5M27C101K15	LSI:M5M27C101K15	
20	S38352101	2	デンゲキラベル.4カコク	LABEL, ELEC. SHOCK 4 LANG.	
21	S38353101	2	デンゲキラベル.7	LABEL, ELEC. SHOCK JPN.	
32	S08030000	1	GEヒューズ5AFB	FUSE, 5A :FB	
33	153242000	1	ヒューズ6A	FUSE, 6A	
34	S48580000	1	GFUSE7AFB	FUSE, 7A :FB	
40	S40635001	1	"オプション部品" ノイズフィルタ430Eクミ	"OPTION PARTS" NOISE FILTER ASSY, 430E	
40-1	S40616001	1	ノイズフィルタEMCクミ	NOISE FILTER ASSY, EMC	
40-2	S40624000	1	ノイズフィルタハーネスA	NOISE FILTER HARNESS, A	
41	0A4400605	4	+ナベサクミ4X6DA	SCREW, PAN (S/P WASHER) M4X6	
42	S42653000	1	コアTFC-23-11-14	CORE :TFC-23-11-14	

BAS-311F-0-502

☆RM欄に※が付いている部品をご注文頂きますと、基板等必要な部品が一式入ったセットになっております。

☆When ordering parts which have an asterisk(※) in the RM column, these parts will be supplied as a set together with other necessary parts such as circuit boards.

N.コントロールボックス関係 / Control box mechanism

REF.NO	CODE	QTY	品名	NAME OF PARTS	RM
			“オプション部品”	“OPTION PARTS”	
42	S42653000	1	コアTFC-23-11-14	CORE :TFC-23-11-14	
43	149809000	1	タイラツPL	BEAD BAND, L=200	
44	S40621000	1	EMICOREESD-SR-15	EMI CORE, ESD-SR-15	
45	S40622000	1	EMICOREESD-SR-25	EMI CORE, ESD-SR-25	
46	S40764000	7	コアTFC25-15-12	CORE :TFC25-15-12	
47	S42653000	1	コアTFC-23-11-14	CORE :TFC-23-11-14	
48	149809000	8	タイラツPL	BEAD BAND, L=200	
49	S40623000	1	EMICORETR-40-27	EMI CORE, TR-40-27	
50	0A5401605	1	ナハサクミ4X16DB	SCREW, PAN (S/P WASHER) M4X16	
51	025040236	1	ヒラサガネチュウ4	WASHER, PLAIN M 4	
52	021400106	1	ナツト1シユ4	NUT, 1 M4	
			“補給用部品”	“For Supply parts”	
			<三相200V, 220V用>	<For “3-phase 200V-220V AC”>	
H-1	S56241101	1	ボックスコンポウクミA1	POWER SUPPLY BOX SET, A1	※
			<単相220V用>	<For “1-phase 220V AC”>	
H-2	S56242101	1	ボックスコンポウクミA2	POWER SUPPLY BOX SET, A2	※
			<単相100V用>	<For Japan only>	
H-3	S56243101	1	ボックスコンポウクミB1	-----	※
			<単相110V用>	<For “1-phase 110V AC”>	
H-4	S56244101	1	ボックスコンポウクミB2	POWER SUPPLY BOX SER, B2	※
			<三相380V用>	<For “3-phase 380V AC”>	
H-5	S56246101	1	ボックスコンポウクミC2	POWER SUPPLY BOX SET, C2	※
			<単相240V用>	<For “1-phase 240V AC”>	
H-6	S56247101	1	ボックスコンポウクミC3	POWER SUPPLY BOX SET, C3	※
			<三相400V用>	<For “3-phase 400V AC”>	
H-7	S56248101	1	ボックスコンポウクミE	POWER SUPPLY BOX SET, 4	※
			<単相230V用>	<For “1-phase 230V AC”>	
H-8	S56249101	1	ボックスコンポウクミF	POWER SUPPLY BOX SET, F	※

BAS-311F-0-502

☆RM欄に※が付いている部品をご注文頂きますと、基板等必要な部品が一式入ったセットになっております。

☆When ordering parts which have an asterisk(※) in the RM column, these parts will be supplied as a set together with other necessary parts such as circuit boards.

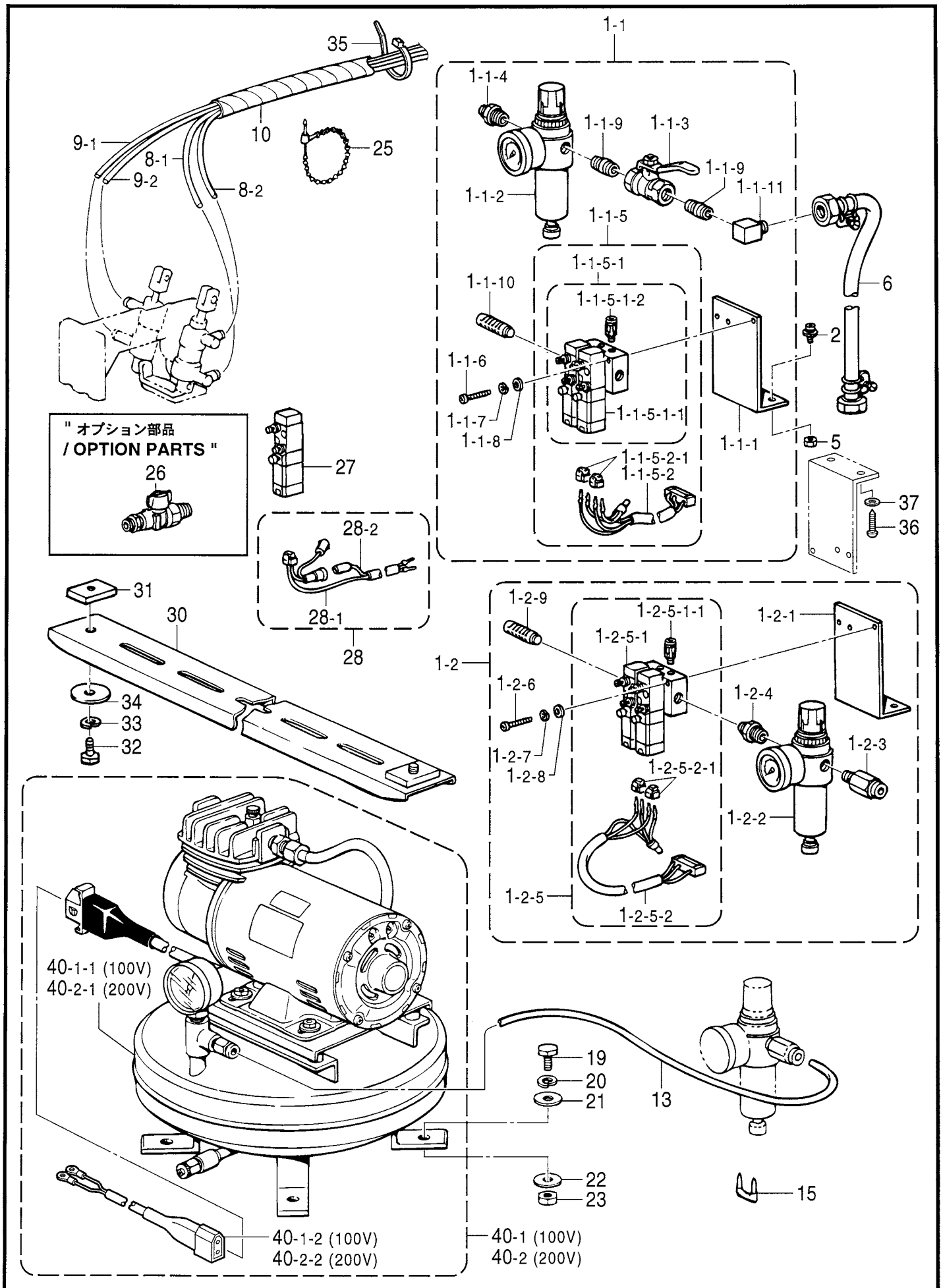

P.空圧関係 / Air pressure mechanism

REF.NO	CODE	Q'TY	品名	NAME OF PARTS	RM
			<コンプレッサー無し仕様用>	<For Without compressor>	
1-1	S43678109	1	ソレノイドバルブ2Aクミ	SOLENOID VALVE ASSY, 2A	
1-1-1	S31551209	1	バルブトリツケイタ2-3	SETTING PLATE, 2-3 :VALVE	
1-1-2	S09318101	1	インテグレータ	INTEGRATOR	
1-1-3	S40628000	1	ボールバルブ1/4	BALL VALVE, 1/4	
1-1-4	S09228000	1	イケイニツプル	NIPPLE, 1/4X1/8	
1-1-5	S43679101	1	ソレノイドバルブ2クミ	SOLENOID VALVE ASSY, 2	
1-1-5-1	S43680001	1	エアマニホルドクミ	AIR MANIFOLD ASSY	
1-1-5-1-1	S43684001	1	エアマニホルド	AIR MANIFOLD	
1-1-5-1-2	S43683001	2	ソレノイドバルブ	SOLENOID VALVE	
1-1-5-1-3	S18415101	4	ハーフユニオンQ4M5	HALF UNION :Q4M5	
1-1-5-2	S43682100	1	バルブハーネスX2クミ	VALVE HARNESS ASSY, X2	
1-1-5-2-1	S12404000	2	クロタバルブコネクタ	VALVE CONNECTOR	
1-1-6	062302506	2	ナベコ3X25	SCREW, PAN M3X25	
1-1-7	028030242	2	ハネサガネ2-3	WASHER, SPRING 2-3	
1-1-8	025030232	2	ヒラサガネチユウ3	WASHER, PLAIN M 3	
1-1-9	S40629000	2	バレルニツプル	BARREL NIPPLE	
1-1-10	S23880000	2	エアマフラー	AIR MUFFLER	
1-1-11	S43686000	1	PTエルボ1/4	ELBOW, PT 1/4	
			<コンプレッサー付仕様用>	<For With compressor>	
1-2	S43694109	1	ソレノイドバルブ2Bクミ	SOLENOID VALVE ASSY, 2B	
1-2-1	S31551209	1	バルブトリツケイタ2-3	SETTING PLATE, 2-3 :VALVE	
1-2-2	S09318101	1	インテグレータ	INTEGRATOR	
1-2-3	S29710000	1	コネクタ6-1/4	CONNECTOR, 6-1/4	
1-2-4	S09228000	1	イケイニツプル	NIPPLE, 1/4X1/8	
1-2-5	S43679101	1	ソレノイドバルブ2クミ	SOLENOID VALVE ASSY, 2	
1-2-5-1	S43680001	1	エアマニホルドクミ	AIR MANIFOLD ASSY	
1-2-5-1-1	S43684001	1	エアマニホルド	AIR MANIFOLD	
1-2-5-1-2	S43683001	2	ソレノイドバルブ	SOLENOID VALVE	
1-2-5-1-3	S18415101	4	ハーフユニオンQ4M5	HALF UNION :Q4M5	
1-2-5-2	S43682100	1	バルブハーネスX2クミ	VALVE HARNESS ASSY, X2	
1-2-5-2-1	S12404000	2	クロタバルブコネクタ	VALVE CONNECTOR	
1-2-6	062302506	2	ナベコ3X25	SCREW, PAN M3X25	
1-2-7	028030242	2	ハネサガネ2-3	WASHER, SPRING 2-3	
1-2-8	025030232	2	ヒラサガネチユウ3	WASHER, PLAIN M 3	
1-2-9	S23880000	2	エアマフラー	AIR MUFFLER	
2	0A5501205	2	+ナベサクミ5X12DB	SCREW, PAN (S/P WASHER) M5X12	
5	021500106	2	1シュナツ5	NUT, 1 M5	
6	149796001	1	ゴムホースカナグツキ	AIR HOSE, W/CONNECTOR	
8-1	S43687001	1	ナイロンチューブR	AIR TUBE, R	
8-2	S43687002	1	ナイロンチューブR	AIR TUBE, R	
9-1	S43688001	1	ナイロンチューブL	AIR TUBE, L	
9-2	S43688002	1	ナイロンチューブL	AIR TUBE, L	
			<311F-0用>	<For 311F-0>	
10	S12212000	1	スパイラル290S	SPIRAL, 290S	
			<311F-L用>	<For 311F-L>	
10	S59695000	1	スパイラル350S	SPIRAL, 350S	
			<326F-0用>	<For 326F-0>	
10	S12212000	1	スパイラル290S	SPIRAL, 290S	

P. 空圧関係 / Air pressure mechanism

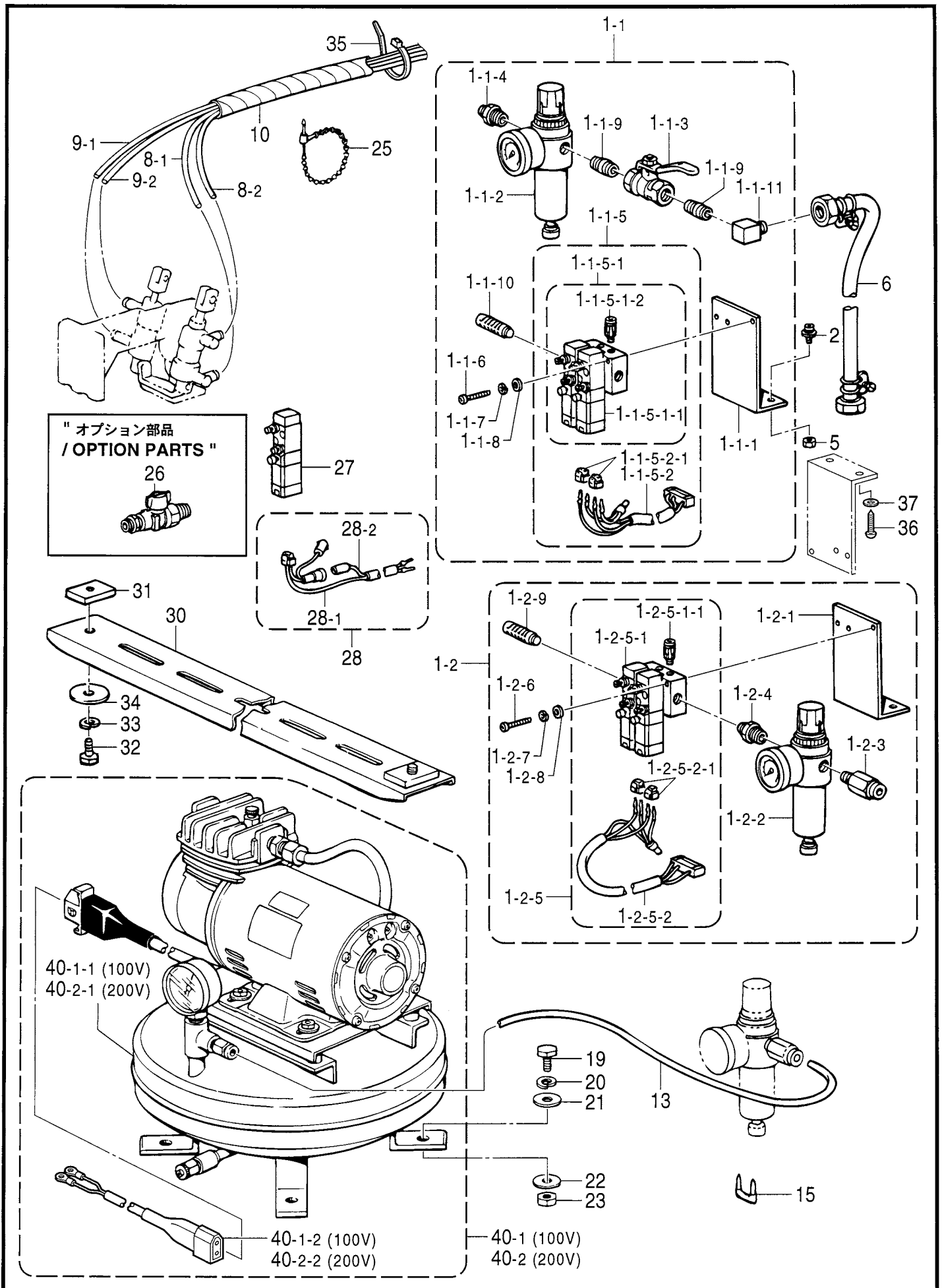

BAS-311F-0-514

REF.NO	CODE	Q'TY	品名	NAME OF PARTS	RM
			<コンプレッサー付仕様用>	<For With compressor>	
13	S46255000	1	エアホース0604S68B	AIR TUBE, 6 :L=680	
15	200190001	3	ステツプル	STAPLE	
19	017082203	4	ボルト8X22	BOLT 8X22	
20	028080242	4	ハネサガネ2-8	WASHER, SPRING 2-8	
21	025080232	4	ヒラサガネチユウ8	WASHER, PLAIN M 8	
22	025080336	4	ヒラサガネダイ8	WASHER, PLAIN L 8	
23	021080106	4	ナツト1シユ8	NUT, 1 M8	
25	340400001	1	ユニタイバンド	BEAD BAND	
27	S43683001	1	ソレノイドバルブ	SOLENOID VALVE	
28	S43696100	1	バルブハーネスX1クミ	VALVE HARNESS ASSY, X1	
28-1	S44746100	1	ツイカバルブハーネス	VALVE HARNESS	
28-2	S44750100	1	ツイカバルブハーネス24V	VALVE HARNESS, 24V	
30	S09224002	1	フミイタササエダイ	TREADLE SUPPORT BASE	
31	S09225001	2	4カケナツト	NUT, SQUARE	
32	017081606	2	ボルト8X16	BOLT, M8X16	
33	028080246	2	ハネサガネ2-8	WASHER, SPRING 2-8	
34	S09226001	2	フミイタササエサガネ	TREADLE SUPPORT WASHER	
35	228475000	2	ケツソクバンド1.9X80	CABLE TIE, 1.9X80	
36	032422003	2	+マルモクネジ4.1X20	WOOD SCREW, ROUND M4.1X20	
37	148847001	2	サガネ	WASHER, PLAIN 4.76	
			"オプション部品"	"OPTION PARTS"	
26	S25100000	1	ボールバルブクミ	BALL VALVE ASSY	
			"補給用部品"	"For Supply parts"	
			<100V用>	<For 100V AC>	
40-1	S50661009	1	コンプレツサユニットクミ	COMPRESSOR UNIT ASSY, 100V AC	
40-1-1	S05670002	1	コンプレツサユニット	COMPRESSOR UNIT, 100V AC	
40-1-2	S43278000	1	コンプレツサハーネス	COMPRESSOR HARNESS	
			<200V用>	<For 200V AC>	
40-2	S50662009	1	コンプレツサユニットクミ	COMPRESSOR UNIT ASSY, 200V AC	
40-2-1	S09393002	1	コンプレツサユニット	COMPRESSOR UNIT, 200V AC	
40-2-2	S43278000	1	コンプレツサハーネス	COMPRESSOR HARNESS	

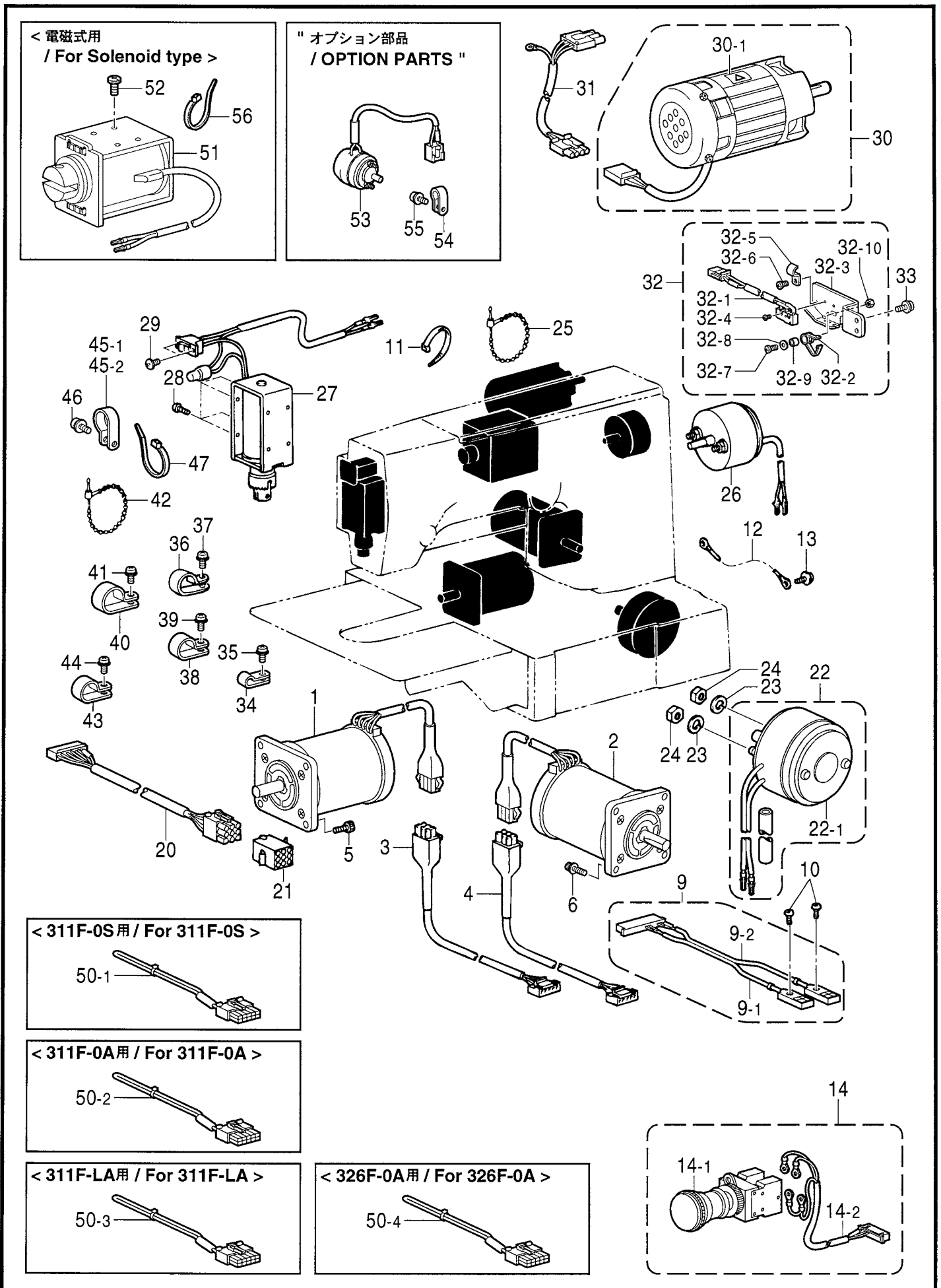

Q.電装品関係 / Power supply equipment mechanism

REF.NO	CODE	Q'TY	品名	NAME OF PARTS	RM
			<311F-0, 311F-L用>	<For 311F-0 & 311F-L>	
1	S50671000	1	パルスモータXクミ	PULSE MOTOR ASSY, X	
2	S50672000	1	パルスモータYクミ	PULSE MOTOR ASSY, Y	
			<326F-0用>	<For 326F-0>	
1	S57836000	1	パルスモータXクミ	PULSE MOTOR ASSY, X	
2	S44372000	1	パルスモータYクミ	PULSE MOTOR ASSY, Y	
3	S43196000	1	パルスモータXハーネス	PULSE MOTOR HARNESS, X	
4	S43197000	1	パルスモータYハーネス	PULSE MOTOR HARNESS, Y	
5	018400832	4	アナホルト4X8	BOLT, SOCKET M4X8	
6	S55481002	4	アナホルトサクミ4X12	BOLT, SOCKET (S/P WASHER)M4X12	
			<311F-0, 311F-L用>	<For 311F-0 & 311F-L>	
9	S56166000	1	ゲンテンセンサハーネスクミ	H-POSITION SENSOR HARNESS ASSY	
9-1	S56167000	1	キンセツセンサGL-N12F	PROXIMITY SENSOR, GL-12NF	
9-2	S56167002	1	キンセツセンサGL-N12F	PROXIMITY SENSOR, GL-12NF	
			<326F-0用>	<For 326F-0>	
9	S56671001	1	ゲンテンセンサハーネスクミ	HOME POSITION HARNESS ASSY	
9-1	S56167001	1	キンセツセンサGL-N12F	PROXIMITY SENSOR, GL-12NF	
9-2	S56167002	1	キンセツセンサGL-N12F	PROXIMITY SENSOR, GL-12NF	
10	002301203	2	+ナベコ3X12	SCREW, PAN M3X12	
11	228475000	1	ケツソクバンド1.9X80	CABLE TIE, 1.9X80	
12	S38148000	1	アースセン1	GROUND WIRE, 1	
13	0A5401006	1	ナベコハネヒラ4X10	SCREW, PAN (S/P WASHER) M4X10	
14	S56169000	1	EMロックスイッチクミ	LOCK SWITCH ASSY, EM	
14-1	S52744000	1	スイッチA22E-M-11	SWITCH, A222E-M-11	
14-2	S43205000	1	EMロックスイッチハーネス	LOCK SWITCH HARNESS, EM	
			<311F-L, 326F-0用>	<For 311F-L & 326F-0>	
20	S43206000	1	ソレノイドハーネスクミ	SOLENOID HARNESS ASSY	
21	S57926000	1	コネクタ3191-09P1	CONNECTOR, 3191-09P1	
22	S43202000	1	カンケツソレノイドクミ	STEPPING SOLENOID ASSY	
22-1	S10244000	1	カンケツソレノイド	STEPPING SOLENOID	
23	021060206	2	2シユナツト6	NUT, 2 M6	
24	028060246	2	ハネサガネ2-6	WASHER, SPRING 2-6	
25	340400001	1	ユニタイバンド	BEAD BAND	
26	S07818009	1	イトキリソレノイド	THREAD TRIMMER SOLENOID	
27	S41202151	1	イトハライソレノイドクミ	THREAD WIPER SOLENOID ASSY	
28	062300616	4	ナベコM3X6	SCREW, PAN M3X6	
29	S55184000	2	+トラスコ3X6	SCREW, TRUSS M3X6	
30	J03647001	1	CIMモータ430クミ	CIM MOTOR ASSY, 430	
30-1	J03663001	1	ラベルコウオン	LABEL, HIGH TEMP.	
31	S56173000	1	IMハーネスクミ	HARNESS ASSY, IM	
32	S56170100	1	トウブイチスイッチクミ	SWITCH ASSY, HEAD	
32-1	S56171000	1	マイクロスイッチクミ	MICRO SWITCH ASSY	
32-2	S38744101	1	スイッチイタハネ	SWITCH PLATE SPRING	
32-3	S55632001	1	スイッチダイ	SWITCH BRACKET	
32-4	062020806	2	ナベコ2X8	SCREW, PAN M2X8	
32-5	140647101	1	コードオサエ	CORD HOLDER	
32-6	062400616	1	ナベコM4X6	SCREW, PAN M4X6	
32-7	062401216	1	ナベコM4X12	SCREW, PAN M4X12	
32-8	026040236	1	ヒラサガネミカキ4	WASHER, PLAIN 4	
32-9	154514001	1	スペーサー	SPACER	

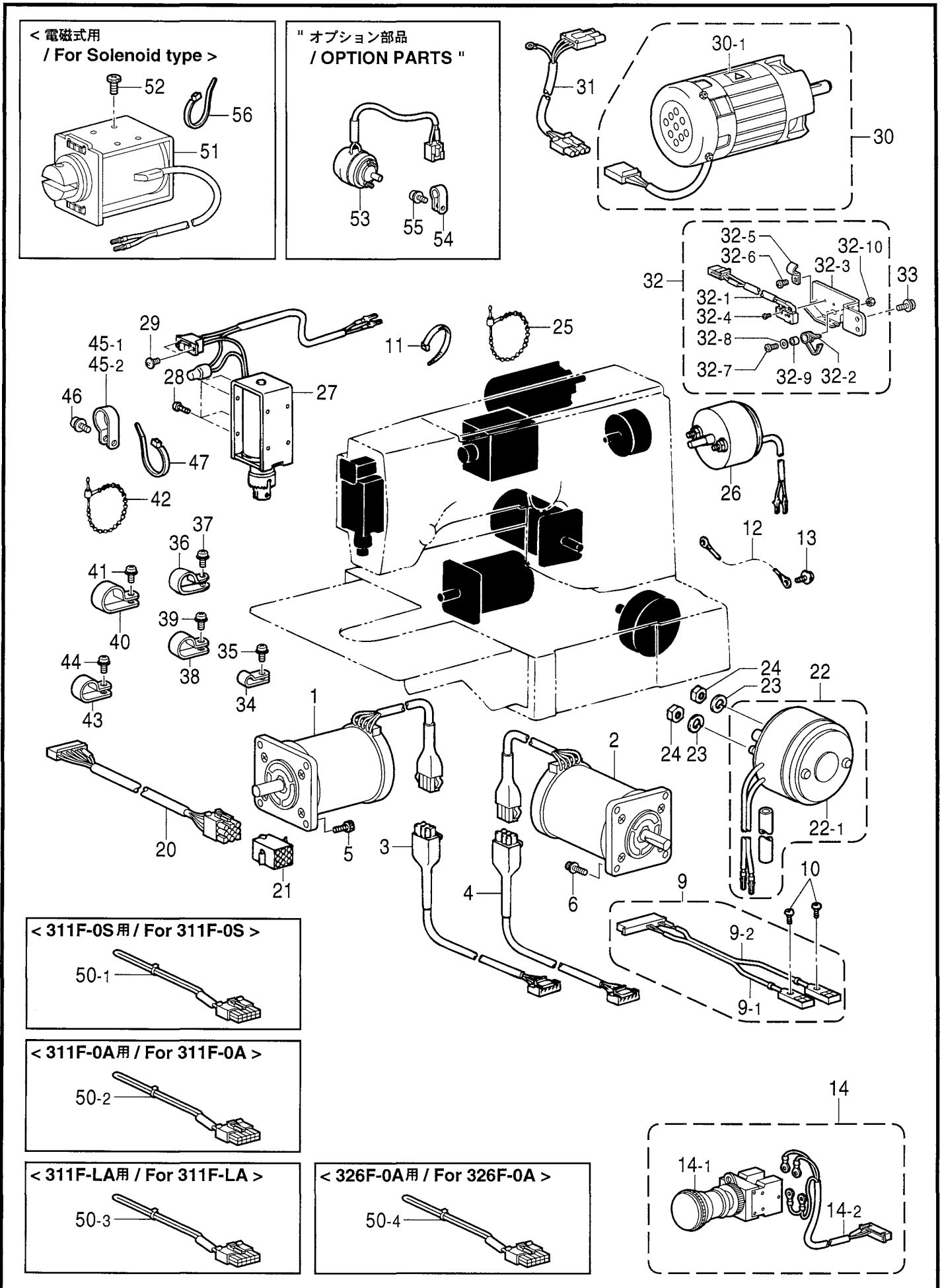

Q.電装品関係 / Power supply equipment mechanism

REF.NO	CODE	Q'TY	品名	NAME OF PARTS	RM
32-10	021400106	1	ナツト1シユ4	NUT, 1 M4	
33	0A5401006	2	ナヘコハネヒラ4X10	SCREW, PAN (S/P WASHER) M4X10	
34	S10243000	3	ナイロンクランプNK-3N	CORD HOLDER, NK-3N	
35	0A5401006	3	ナヘコハネヒラ4X10	SCREW, PAN (S/P WASHER) M4X10	
36	149287000	2	ナイロンクランプ	CORD HOLDER, 7N	
37	0A5401006	2	ナヘコハネヒラ4X10	SCREW, PAN (S/P WASHER) M4X10	
38	149287000	3	ナイロンクランプ	CORD HOLDER, 7N	
39	0A5401006	3	ナヘコハネヒラ4X10	SCREW, PAN (S/P WASHER) M4X10	
40	554482000	2	コードホルダ#12	CORD HOLDER, #12	
41	0A5401006	2	ナヘコハネヒラ4X10	SCREW, PAN (S/P WASHER) M4X10	
42	340400001	4	ユニタイバンド	BEAD BAND	
43	149287000	1	ナイロンクランプ	CORD HOLDER, 7N	
44	0A5401006	1	ナヘコハネヒラ4X10	SCREW, PAN (S/P WASHER) M4X10	
			<電磁式用>	<For Solenoid type>	
45-1	149287000	1	ナイロンクランプ	CORD HOLDER, 7N	
			<エア-式用>	<For Pneumatic type>	
45-2	525664000	1	コードホルダ#6	CORD HOLDER, #6	
47	228475000	3	ケツツクバンド1.9X80	CABLE TIE, 1.9X80	
			<共通部品>	<Common parts>	
46	0A5401006	1	ナヘコハネヒラ4X10	SCREW, PAN (S/P WASHER) M4X10	
			<311F-0S用>	<For 311F-0S>	
50-1	S56168000	1	シヨウキリカエコネクタタミ	CONVERSION CONNECTOR ASSY	
			<311F-0A用>	<For 311F-0A>	
50-2	S56168001	1	シヨウキリカエコネクタタミ	CONVERSION CONNECTOR ASSY	
			<311F-LA用>	<For 311F-LA>	
50-3	S56168002	1	シヨウキリカエコネクタタミ	CONVERSION CONNECTOR ASSY	
			<326F-0A用>	<For 326F-0A>	
50-4	S56168003	1	シヨウキリカエコネクタタミ	CONVERSION CONNECTOR ASSY	
			<311F-0S用>	<For 311F-0S>	
51	S55916201	1	オサエソレノイドタミ	PRESSER SOLENOID ASSY	
52	S59898001	4	バインド5X14	SCREW, BIND M5X14	
56	218859001	1	バインダM150	BINDER, M150	
			"オプション部品"	"OPTION PARTS"	
53	S56172000	1	イトリソレノイドタミ	SOLENOID ASSY, TR	
54	149287000	2	ナイロンクランプ	CORD HOLDER, 7N	
55	0A5401006	2	ナヘコハネヒラ4X10	SCREW, PAN (S/P WASHER) M4X10	

R. プリント基板関係 / Printed circuit board mechanism

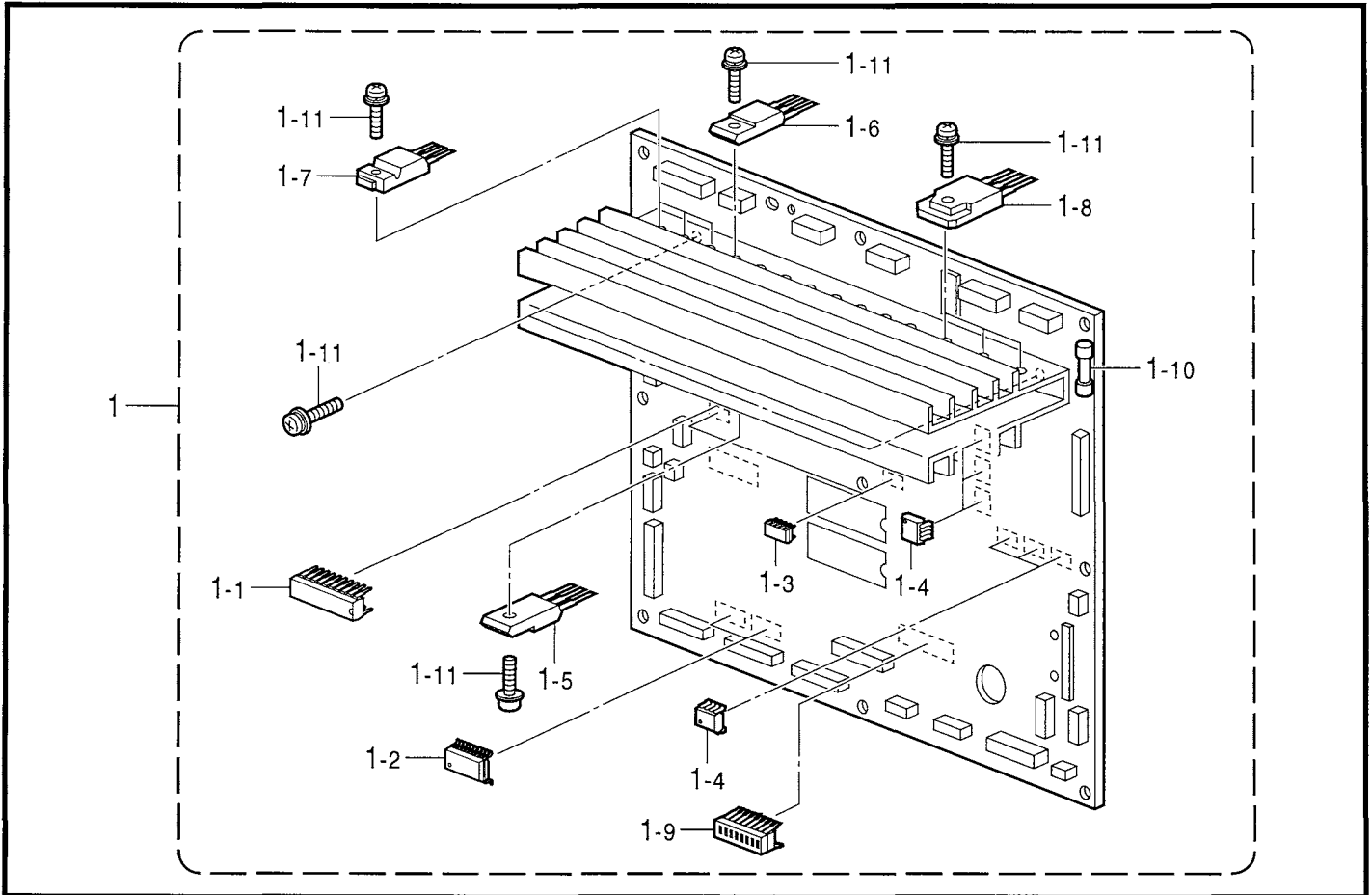

BAS-311F-0-518

S. プログラマー関係 (オプション部品) / Programmer (Option parts)

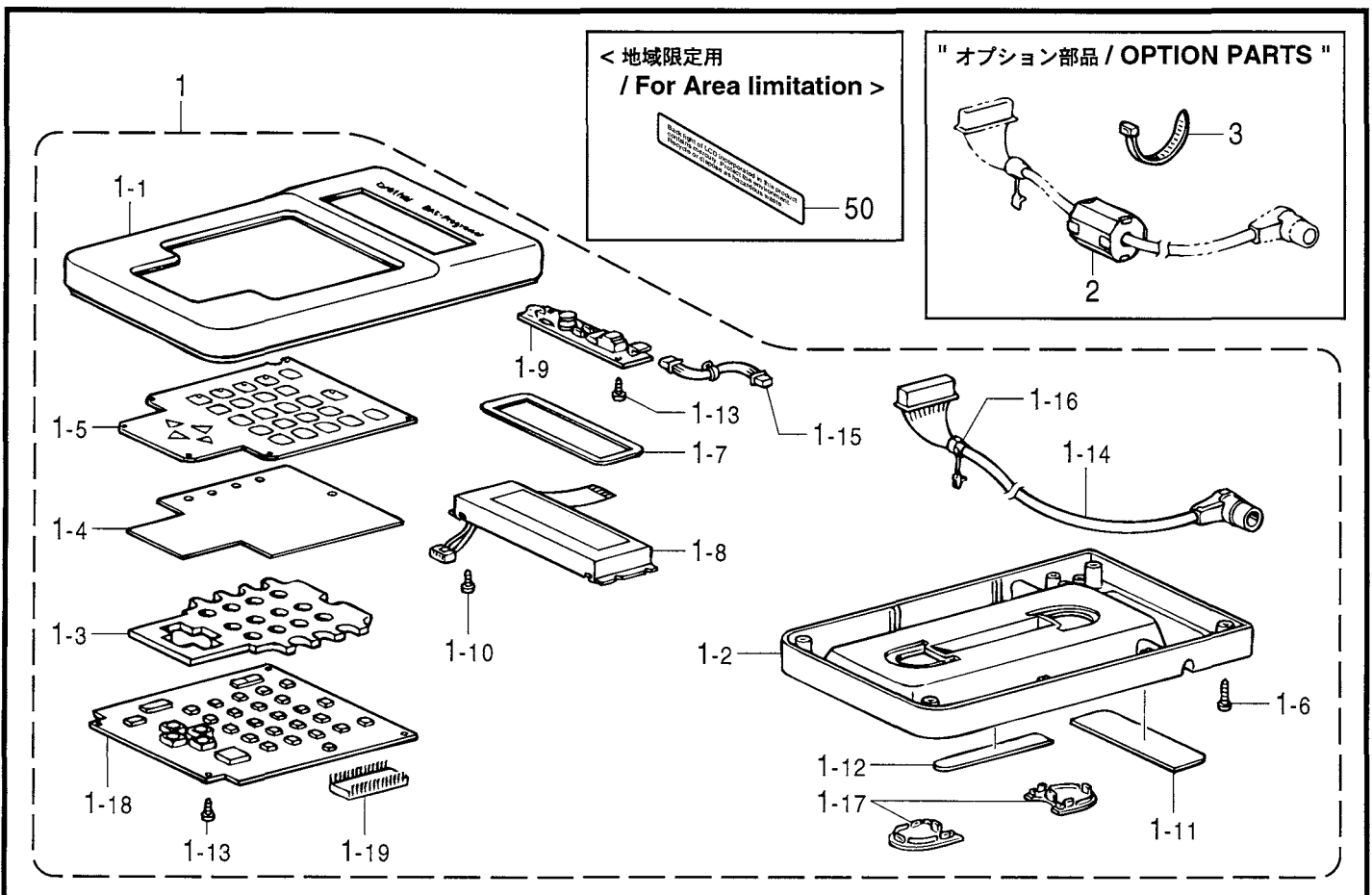

BAS-311F-0-942

R.プリント基板関係 / Printed circuit board mechanism

REF.NO	CODE	Q'TY	品名	NAME OF PARTS	RM
1	S53884001	1	メイン基板	MAIN PCB ASSY	
1-1	S43126000	1	PLD-INVD-960	LCI,PLD-INVD	
1-2	S42691000	2	TRアレイ	TRANSISTOR ARRAY	
1-3	091170007	2	BIPIC74LS07FT	IC:74LS07FT	
1-4	S43178000	6	PHカプラPC9231	PHOTO COUPLER:PC9231	
1-5	S49485000	10	MOSFETFX6KMJ-2	TRANSISTOR, FET:FX6KMJ-2	
1-6	S49484000	10	MOSFETFS10KMJ-2	TRANSISTOR, FET:FS10KMJ-2	
1-7	S38155000	5	MOSFET2SK1306	TRANSISTOR, FET:2SK1306	
1-8	S49471000	6	MOSFETFK18SM-12	TRANSISTOR, FET:FK18SM-12	
1-9	U32744000	2	DIPSWDSS708	DIP SWITCH:DSS708	
1-10	S48578000	1	GFUSE5AFBリードツキ	GLASS FUSE, 5A W/LEED WIRE	
1-11	0A4301005	33	ナベサグミ3X10DA	SCREW, PAN (S/P WASHER) M3X10	

BAS-311F-0-518

S.プログラマー関係 (オプション部品) / Programmer (Option parts)

REF.NO	CODE	Q'TY	品名	NAME OF PARTS	RM
1	S43249101	1	プログラマー	PROGRAMMER ASSY	
1-1	S43250100	1	プログラマー上蓋	PROGRAMMER TOP COVER	
1-2	S43251000	1	プログラマー下蓋	PROGRAMMER LOWER COVER	
1-3	S43252000	1	キーボードスペーサ	KEYBOARD SPACER	
1-4	S43253000	1	キーボードゴムシート	KEYBOARD RUBBER SHEET	
1-5	S43254100	1	キーボードシート	KEYBOARD SHEET	
1-6	037301015	4	Vナベタツピン3X10	TAPPING SCREW, PAN V M3X10	
1-7	S43255000	1	LCDカバー	LCD COVER	
1-8	S43256000	1	LCD	LCD	
1-9	S59652000	1	LCDインバーターF1A	INVERTER, LCD :F1A	
1-10	037200615	4	Vナベタツピン2X6	TAPPING SCREW, PAN V M2X6	
1-11	S43271000	1	プログラマーマグネットA	MAGNET, A	
1-12	S43272000	1	プログラマーマグネットB	MAGNET, B	
1-13	037300615	6	Vナベタツピン3X6	TAPPING SCREW, PAN V M3X6	
1-14	S43267000	1	プログラマーコード	PROGRAMMER HARNESS	
1-15	S43268000	1	インバーターハーネス	INVERTER HARNESS	
1-16	S43270000	1	コードブッシュKR51	CORD BUSH, KR51	
1-17	S43981000	2	プログラマーシタカバー	PROGRAMMER UNDER COVER	
1-18	S43259101	1	プログラマー基板	PROGRAMMER PCB ASSY	
1-19	S43269000	1	PROMプログラマー	PROM PROGRAMMER ASSY	
			"オプション部品"	"OPTION PARTS"	
2	S40621000	1	EMIコアESD-SR-15	EMI CORE, ESD-SR-15	
3	149809000	1	タイラップL	BEAD BAND, L=200	
			<地域限定用>	<For Area limitation>	
50	S52582001	1	スイキンケイコラベルP2	MERCURY WARNING LABEL 14X70 P2	

BAS-311F-0-942

T. 操作パネル関係 / Operation panel mechanism

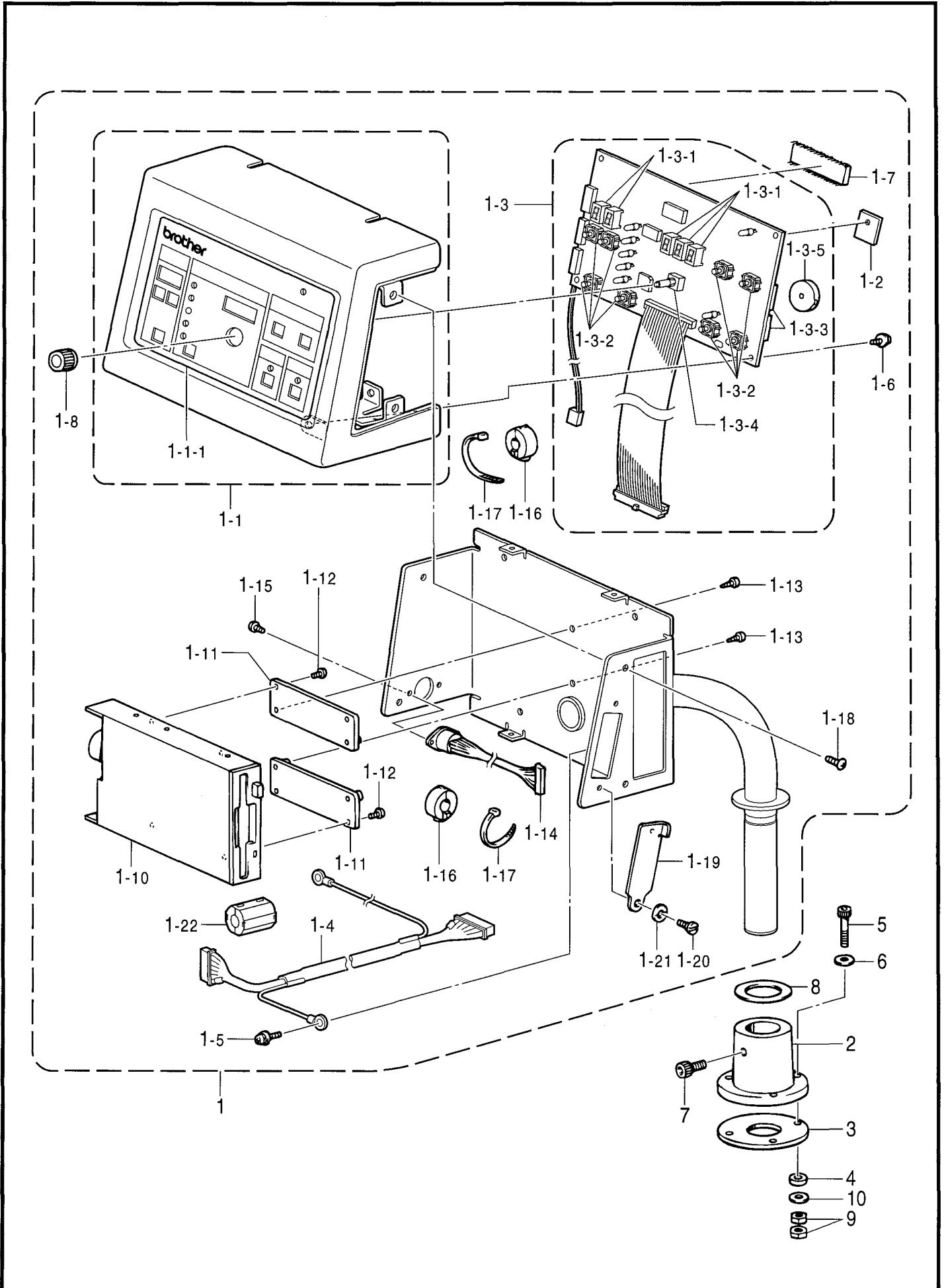

BAS-311F-0-530

T.操作パネル関係 / Operation panel mechanism

REF.NO	CODE	QTY	品名	NAME OF PARTS	RM
1	S58851001	1	ソウサハネルクミ	OPERATION PANEL ASSY	
1-1	S55154001	1	ソウサハネルマエクミ	OPERATION PANEL FRONT ASSY	
1-1-1	S55155000	1	ソサハネルフィルム	OPERATION PANEL FILM	
1-2	S49938000	1	ゼツエンシート	INSULATION SHEET	
1-3	S56151101	1	ハネルキバンクミ	PANEL PCB ASSY	
1-3-1	S29023000	5	LEDGL9P040	LED :GL9P040	
1-3-2	S48579000	8	SWB3F-4050	SWITCH :B3F-4050	
1-3-3	U34870001	2	DIPSW KSP08	DIP SWITCH:KSP08	
1-3-4	S38104000	1	エンコーダEVQVEMF01	ENCODER, EVQVEMF01	
1-3-5	417382001	1	PKB24SC-3601	BUZZER:PKB24SC-3601	
1-4	S55402200	1	ハネルコードクミ	PANEL HARNESS ASSY	
1-5	0A5400805	1	+ナヘザクミ4X8DB	SCREW, PAN (S/P WASHER) M4X8	
1-6	0A4300605	4	+ナヘザクミ3X6DA	SCREW, PAN (S/P WASHER) M3X6	
1-7	S43237100	1	PROMハネルクミ	PROM ASSY, PANEL	
1-8	S02907000	1	ツマミ	THUMB	
1-10	S43224000	1	3.5FDD	FDD, 3.5	
1-11	S43225000	2	FDDスベサ	SPACER, FDD	
1-12	0A4300605	4	+ナヘザクミ3X6DA	SCREW, PAN (S/P WASHER) M3X6	
1-13	037300816	4	Vナヘタツピン3X8	TAPPING SCREW, PAN V M3X8	
1-14	S43228000	1	プログラマコードPクミ	PROGRAMMER HARNESS ASSY, P	
1-15	002300603	2	+ナヘコ3X6	SCREW, PAN M3X6	
1-16	S42653000	2	コアTFC-23-11-14	CORE :TFC-23-11-14	
1-17	149809000	2	タイラツPL	BEAD BAND, L=200	
1-18	S55151000	12	トラスコ4X6	SCREW, TRUSS M4X6	
1-19	S36008009	1	ハネルヨコカバー	SIDE COVER, PANEL	
1-20	107321009	1	ダンネシ4.76	SHOULDER SCREW, SM4.76	
1-21	107017001	1	ナミハネサガネ	WAVE WASHER	
1-22	S51241000	1	EMIコアE1630MRF	CORE, EMI :E1630MRF	
2	S43236009	1	ソウサハネルトダイ	OPERATION PANEL BASE	
3	S43674000	1	クツシヨンA	CUSHION, A	
4	S43675000	3	クツシヨンB	CUSHION, B	
5	S25634101	3	アナホルト5X65	BOLT, SOCKET M5X65	
6	025050236	3	ヒラサガネチュウ5	WASHER, PLAIN M 5	
7	018081636	1	アナホルト8X16	BOLT, SOCKET M8X16	
8	S10408000	1	ゴムシート	RUBBER SHEET	
9	021500106	6	1シュナツ5	NUT, 1 M5	
10	025050336	3	ヒラサガネダイ5	WASHER, PLAIN L 5	

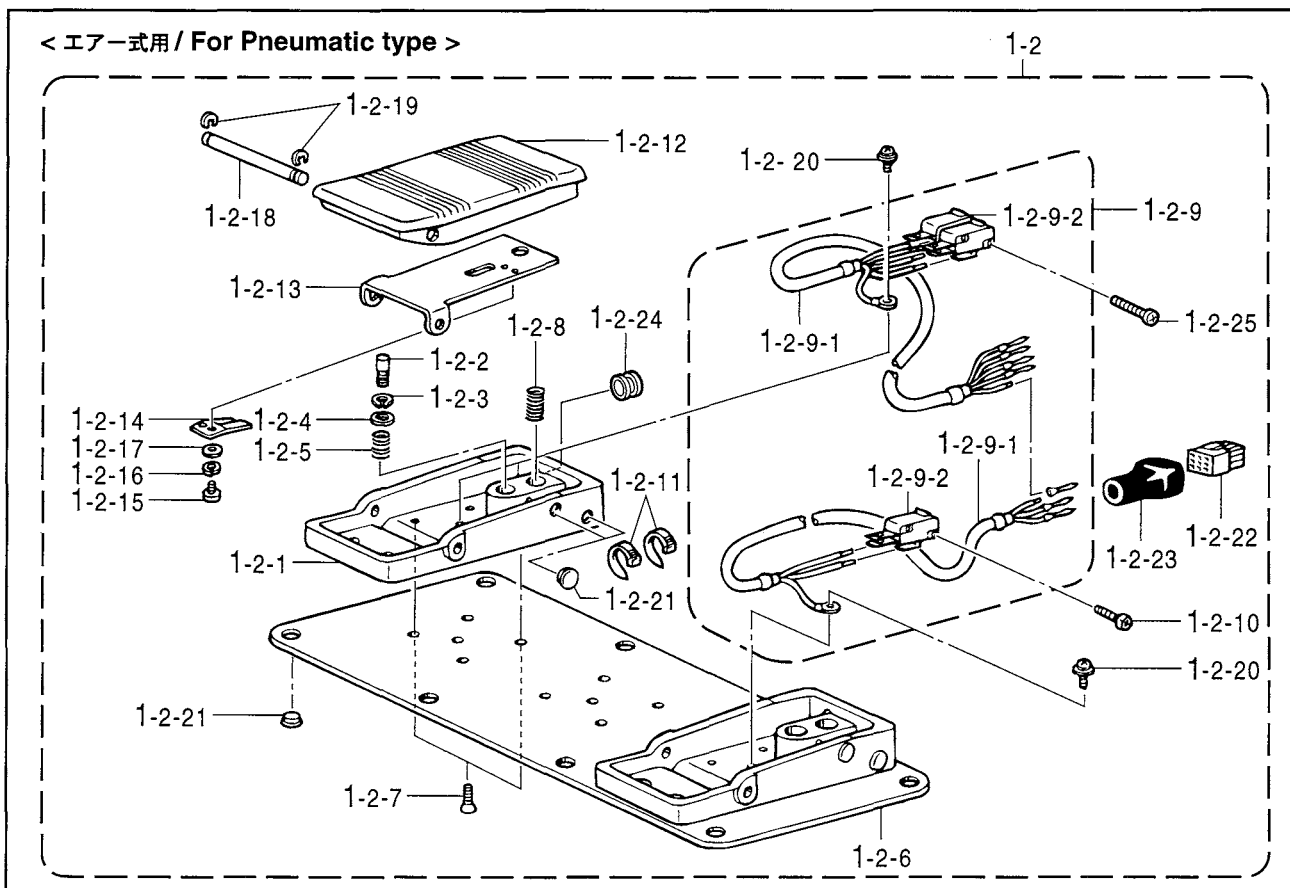
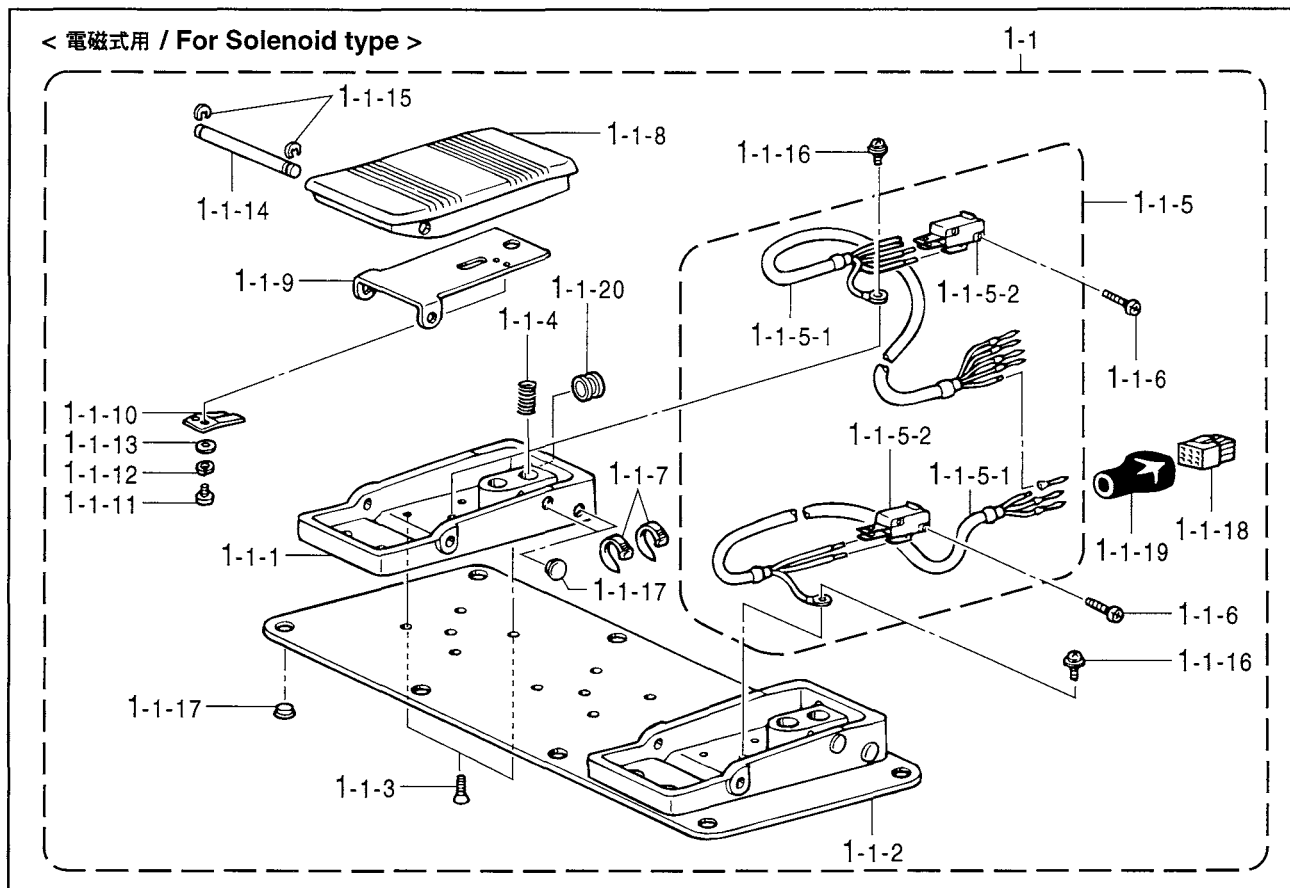

U1.踏板関係 / Foot switch pedal mechanism

REF.NO	CODE	Q'TY	品名	NAME OF PARTS	RM
			<電磁式用>	<For Solenoid type>	
1-1	S42838101	1	2レンフツト2SW	2-PEDAL FOOT SWITCH, 2	
1-1-1	S38166000	2	フツトペダルダイ	FOOT PEDAL BASE	
1-1-2	S42867001	1	フミイタホジヨイタ	TREADLE AUXILIARY PLATE	
1-1-3	004400603	4	+サラコネジ 4X6	SCREW, FLAT M4X6	
1-1-4	S38170001	2	フツトペダルバネ	FOOT PEDAL SPRING	
1-1-5	S38029000	1	2レンフツトSWハーネスクミ	2-PEDAL FOOT SW HARNESS ASSY	
1-1-5-1	S38030000	2	2レンフツトSWハーネス	2-PEDAL FOOT SW HARNESS	
1-1-5-2	S36260000	2	スイッチVXピンボタン	PIN BUTTON MICRO SWITCH, VX	
1-1-6	062301205	4	ナベコ3X12	SCREW, PAN M3X12	
1-1-7	228475000	12	ケツツクバンド 1.9X80	CABLE TIE, 1.9X80	
1-1-8	S38174000	2	フツトペダル	FOOT PEDAL	
1-1-9	S38175001	2	ペダルホコイタ	PROTECTION PLATE, PEDAL	
1-1-10	S38176101	2	スイッチオサエバネ	SPRING, PLATE	
1-1-11	002300403	4	+ナベコ3X4	SCREW, PAN M3X4	
1-1-12	028030246	4	ハネサガネ2-3	WASHER, SPRING 2-3	
1-1-13	025030236	4	ヒラサガネチユウ3	WASHER, PLAIN M 3	
1-1-14	S38177001	2	フツトペダルジク	FOOT PEDAL SHAFT	
1-1-15	048050346	4	トメワE5	RETAINING RING, E5	
1-1-16	052400606	2	ナベコハネヒラ4X6	SCREW, PAN (S/P WASHER) M4X6	
1-1-17	117936001	12	ゴムセン9.4	RUBBER CAP, 9.4	
1-1-18	S38180000	1	コネクタ172169-1	CONNECTOR :172169-1	
1-1-19	S38060000	1	コネクタキャップ18X19	CONNECTOR CAP, 18X19	
1-1-20	S38059000	2	ゴムメツトNG79F	RUBBER CAP, NG79F	
			<エア-式用>	<For Pneumatic type>	
1-2	S42842101	1	2レンフツト3SW	2-PEDAL FOOT SWITCH, 3	
1-2-1	S38166000	2	フツトペダルダイ	FOOT PEDAL BASE	
1-2-2	S38167001	1	2ダンSWピン	SWITCH PIN, 2-STEP	
1-2-3	048060142	1	トメワジクヨウ C6	RETAINING RING, E6	
1-2-4	025060236	1	ヒラサガネチユウ6	WASHER, PLAIN M 6	
1-2-5	S38168001	1	アツシユクハネ	SPRING, COMPRESSION 10X30	
1-2-6	S42867001	1	フミイタホジヨイタ	TREADLE AUXILIARY PLATE	
1-2-7	004400603	4	+サラコネジ 4X6	SCREW, FLAT M4X6	
1-2-8	S38170001	2	フツトペダルバネ	FOOT PEDAL SPRING	
1-2-9	S42259000	1	2レンフツト3SWハーネスクミ	2-PEDAL FOOT SW HARN. ASSY, 3	
1-2-9-1	S42258000	1	2レンフツト3SWハーネス	2-PEDAL FOOT SW HARNESS, 3	
1-2-9-2	S36260000	3	スイッチVXピンボタン	PIN BUTTON MICRO SWITCH, VX	
1-2-10	062301205	2	ナベコ3X12	SCREW, PAN M3X12	
1-2-11	228475000	12	ケツツクバンド 1.9X80	CABLE TIE, 1.9X80	
1-2-12	S38174000	2	フツトペダル	FOOT PEDAL	
1-2-13	S38175001	2	ペダルホコイタ	PROTECTION PLATE, PEDAL	
1-2-14	S38176101	2	スイッチオサエバネ	SPRING, PLATE	
1-2-15	002300403	4	+ナベコ3X4	SCREW, PAN M3X4	
1-2-16	028030246	4	ハネサガネ2-3	WASHER, SPRING 2-3	
1-2-17	025030236	4	ヒラサガネチユウ3	WASHER, PLAIN M 3	
1-2-18	S38177001	2	フツトペダルジク	FOOT PEDAL SHAFT	
1-2-19	048050346	4	トメワE5	RETAINING RING, E5	
1-2-20	052400606	2	ナベコハネヒラ4X6	SCREW, PAN (S/P WASHER) M4X6	
1-2-21	117936001	12	ゴムセン9.4	RUBBER CAP, 9.4	
1-2-22	S38180000	1	コネクタ172169-1	CONNECTOR :172169-1	
1-2-23	S38060000	1	コネクタキャップ18X19	CONNECTOR CAP, 18X19	
1-2-24	S38059000	2	ゴムメツトNG79F	RUBBER CAP, NG79F	
1-2-25	062302506	2	ナベコ3X25	SCREW, PAN M3X25	

U2 . 踏板関係 (オプション部品) / Foot switch pedal mechanism (Option parts)

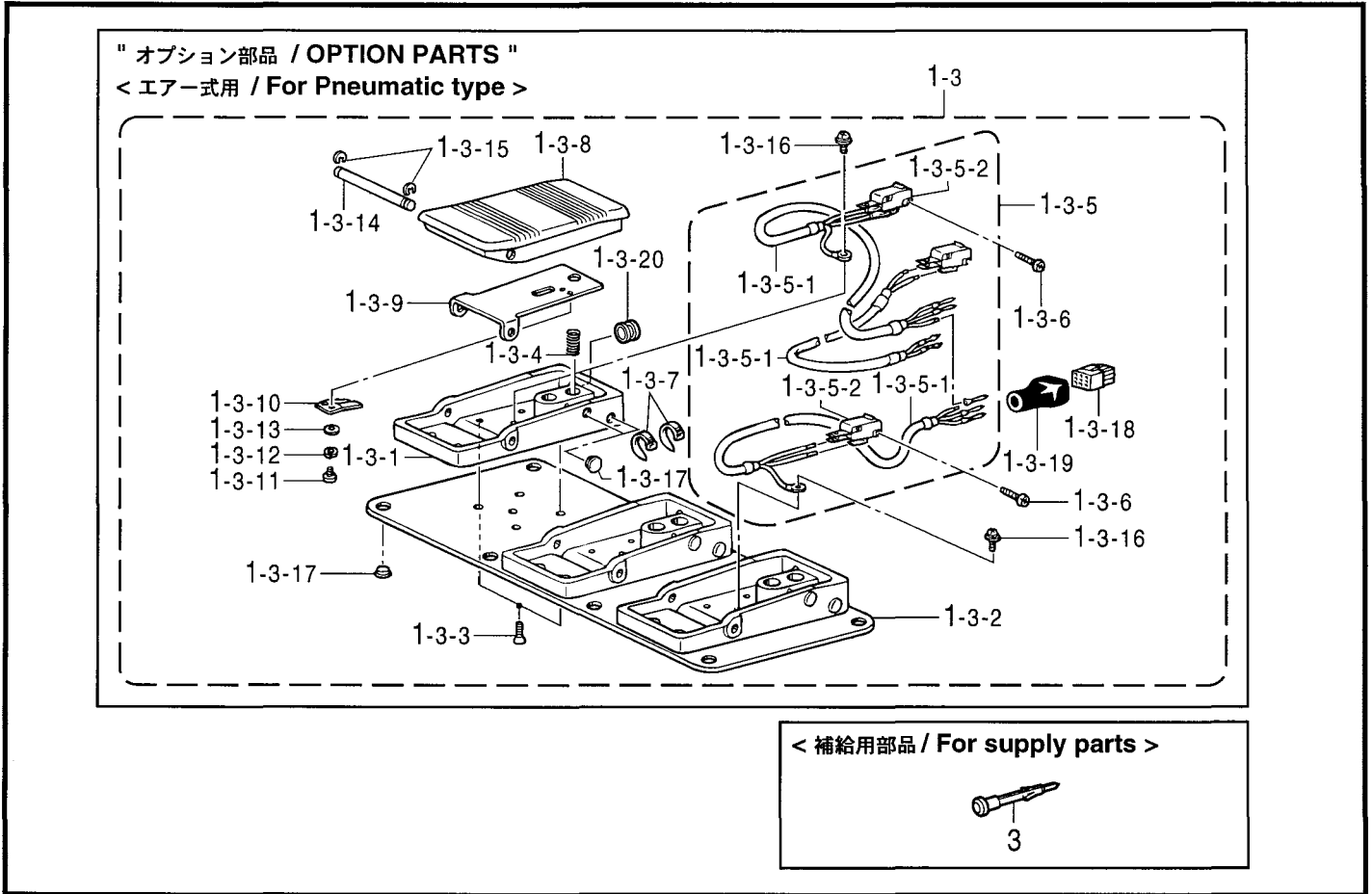

BAS-311F-0-651

V . 針位置検出器関係 / Synchronizer

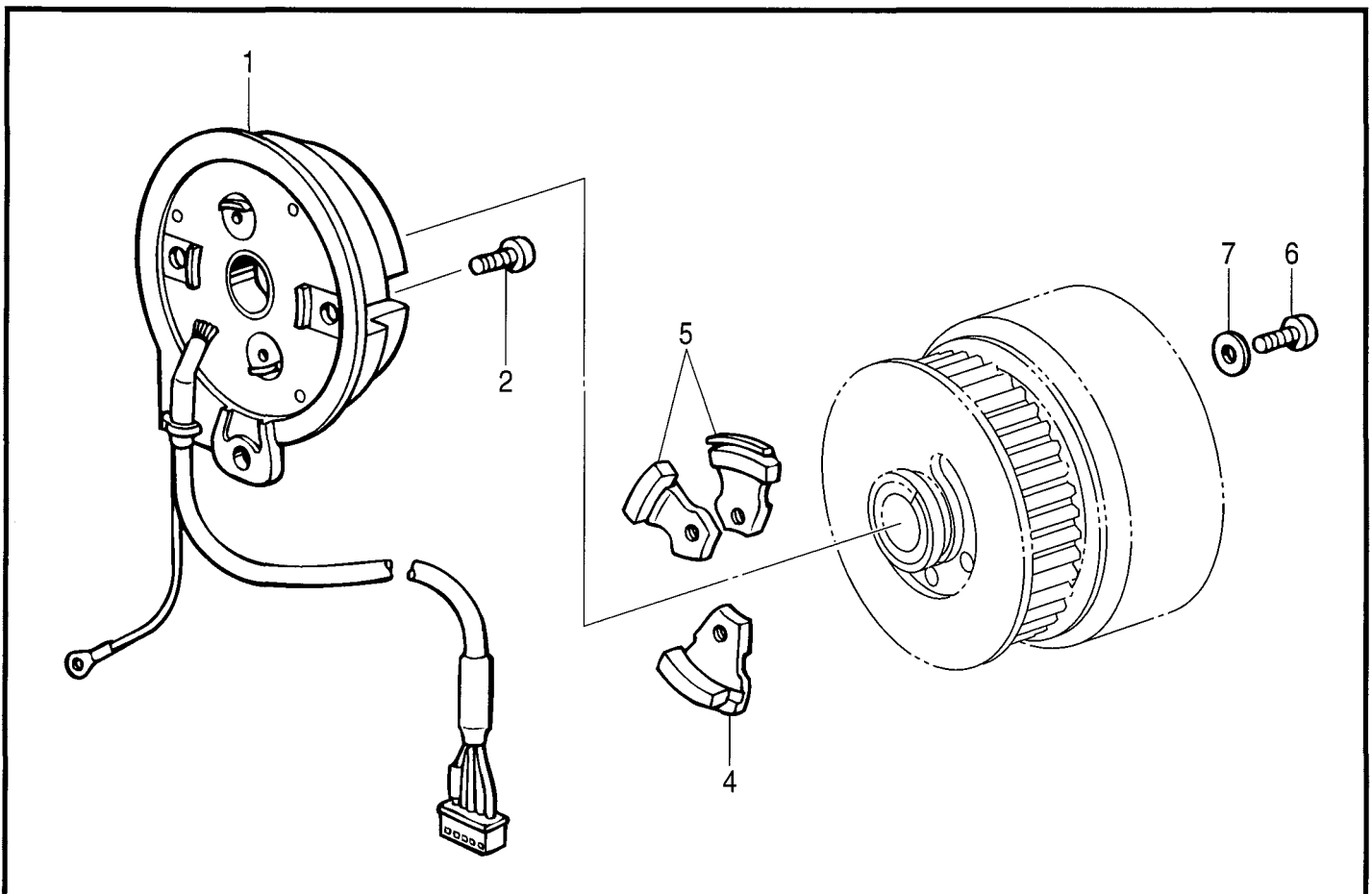

BAS-311F-0-501

U2.踏板関係 (オプション部品) / Foot switch pedal mechanism (Option parts)

REF.NO	CODE	Q'TY	品名	NAME OF PARTS	RM
			<エア-式用>	<For Pneumatic type>	
1-3	S44805101	1	3レンフツ3SW	3-PEDAL FOOT SWITCH, 3	
1-3-1	S38166000	3	フツペタルダイ	FOOT PEDAL BASE	
1-3-2	S42867001	1	フミイタホジヨイタ	TREADLE AUXILIARY PLATE	
1-3-3	004400603	6	+サラコネジ 4X6	SCREW, FLAT M4X6	
1-3-4	S38170001	3	フツペタルバネ	FOOT PEDAL SPRING	
1-3-5	S44806000	1	3レンフツSWハーネスカミ	3-PEDAL FOOT SW HARNESS ASSY	
1-3-5-1	S44807000	1	3レンフツSWハーネス	3-PEDAL FOOT SW HARNESS	
1-3-5-2	S36260000	3	スイッチVXピンボタン	PIN BUTTON MICRO SWITCH, VX	
1-3-6	062301205	6	ナベコ3X12	SCREW, PAN M3X12	
1-3-7	228475000	14	ケツクバント 1.9X80	CABLE TIE, 1.9X80	
1-3-8	S38174000	3	フツペタル	FOOT PEDAL	
1-3-9	S38175001	3	ペダルホコイタ	PROTECTION PLATE, PEDAL	
1-3-10	S38176101	3	スイッチオサエバネ	SPRING, PLATE	
1-3-11	002300403	6	+ナベコ3X4	SCREW, PAN M3X4	
1-3-12	028030246	6	ハネサガネ2-3	WASHER, SPRING 2-3	
1-3-13	025030236	6	ヒラサガネチユウ3	WASHER, PLAIN M 3	
1-3-14	S38177001	3	フツペタルジク	FOOT PEDAL SHAFT	
1-3-15	048050346	6	トメE5	RETAINING RING, E5	
1-3-16	052400606	2	ナベコハネヒラ4X6	SCREW, PAN (S/P WASHER) M4X6	
1-3-17	117936001	14	ゴムセン9.4	RUBBER CAP, 9.4	
1-3-18	S38180000	1	コネクタ172169-1	CONNECTOR :172169-1	
1-3-19	S38060000	1	コネクタキャップ18X19	CONNECTOR CAP, 18X19	
1-3-20	S38059000	3	ゴムメットNG79F	RUBBER CAP, NG79F	
			<補給用部品>	<For Supply parts>	
3	S49443000	1	コンタクト170364-1	CONTACT :170364-1	

BAS-311F-0-651

V.針位置検出器関係 / Synchronizer

REF.NO	CODE	Q'TY	品名	NAME OF PARTS	RM
1	S48666001	1	シンクロナイザカミ	SYNCHRONIZER ASSY	
2	062400806	2	ナベコ4X8	SCREW, PAN M4X8	
4	S38080001	1	ハリシタジシヤクミ	NEEDLE LOWER MAGNET ASSY, D	
5	S38082001	2	ハリウエジシヤクミ	NEEDLE UPPER MAGNET ASSY, U	
6	062681412	3	ナベコ437-40X14	SCREW, PAN SM4.37-40X14	
7	025680132	3	ヒラサガネシヨウ4.37	WASHER, PLAIN S 4.37	

BAS-311F-0-501

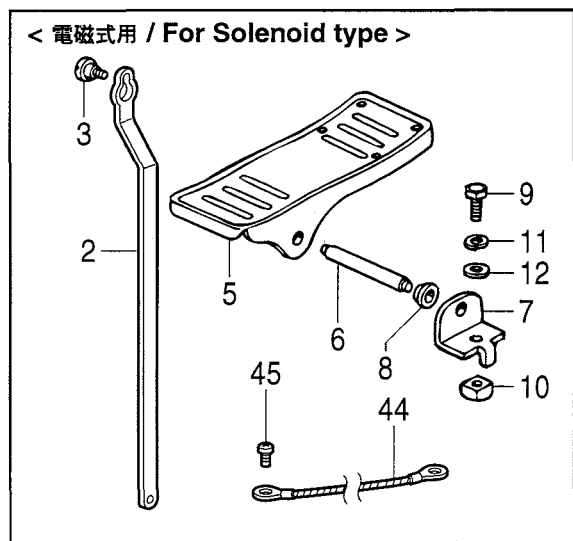
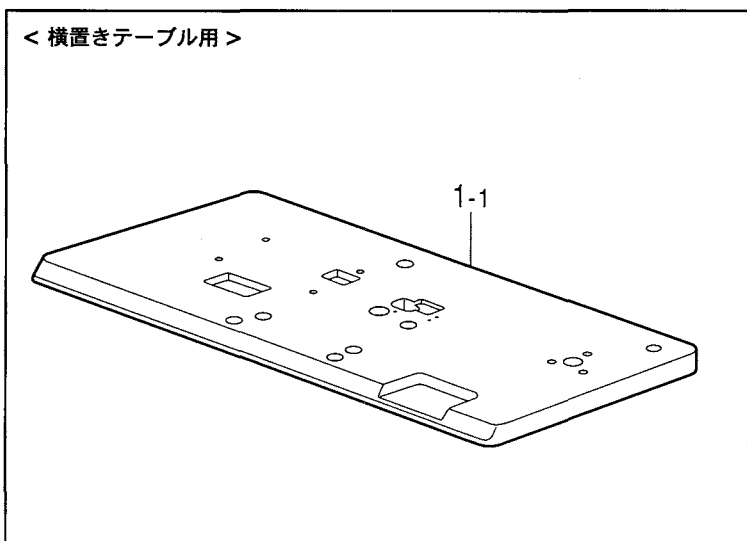
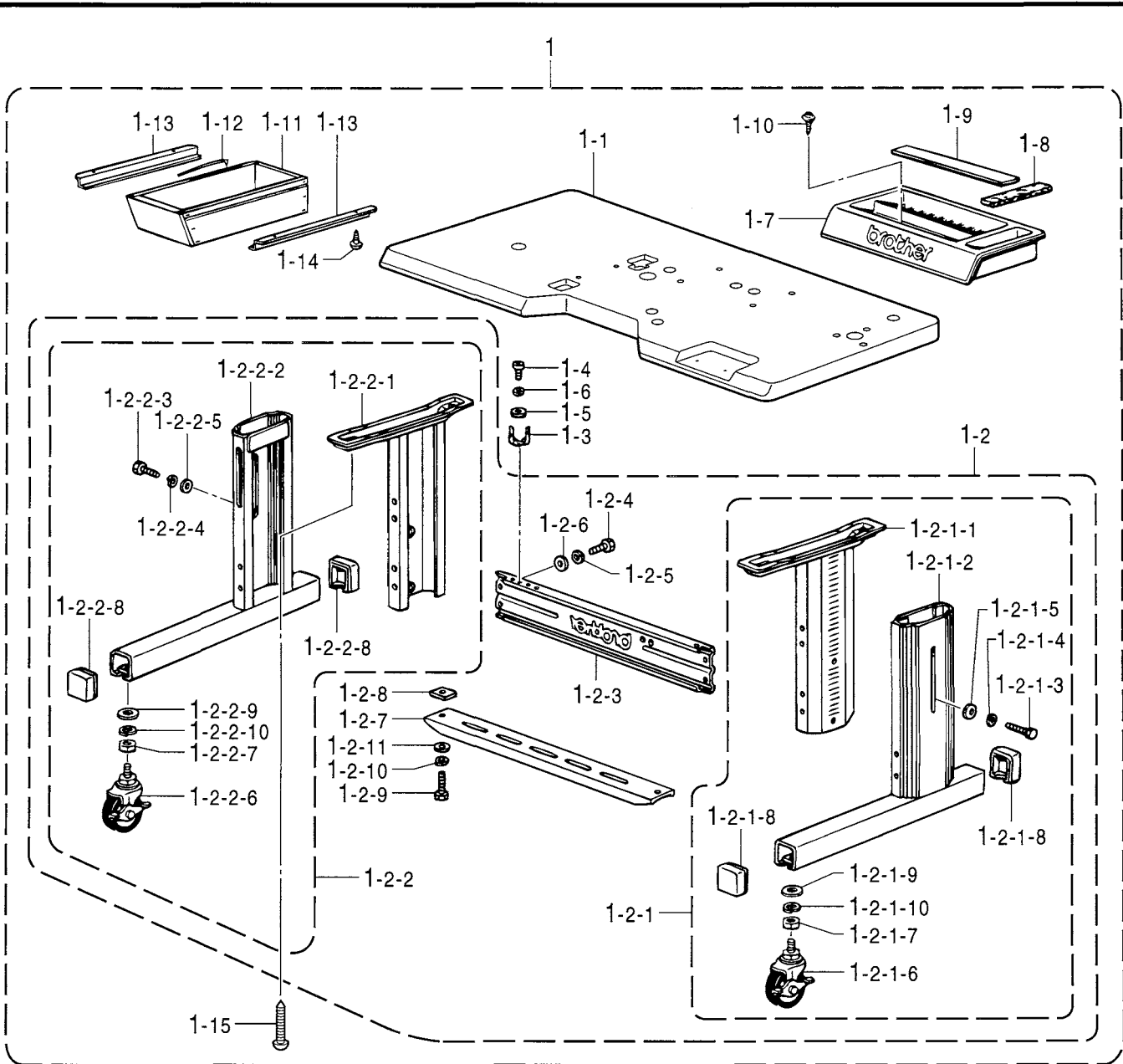

W.動力台関係 / Power table

REF.NO	CODE	Q'TY	品名	NAME OF PARTS	RM
			<国内用標準テーブル>	<For Japan only>	
1	S55919001	1	311テーブルキヤクミ	-----	
1-1	S55160001	1	311Fテーブル	-----	
			"オプション部品"	"OPTION PARTS"	
			<横置きテーブル用>		
1	S55920001	1	311テーブルキヤクヨコミ	-----	
1-1	S55921001	1	311Fテーブルヨコ	-----	
1-2	S43671109	1	タチヨウキヤクミ	-----	
1-2-1	S09639009	1	タチキヤクRクミ	-----	
1-2-1-1	S09216002	1	テーブルササエR	-----	
1-2-1-2	S09217102	1	ソトアシR	-----	
1-2-1-3	017081606	3	ホルト8X16	-----	
1-2-1-4	028080246	3	ハネサガネ2-8	-----	
1-2-1-5	S09312001	3	ヒラサガネダイ8	-----	
1-2-1-6	S05223001	2	キヤスター	-----	
1-2-1-7	022120306	2	ナツト3シユ12	-----	
1-2-1-8	S10661109	2	ソトアシフタコム	-----	
1-2-1-9	026120236	2	ヒラサガネミガキ12	-----	
1-2-1-10	028120246	2	ハネサガネ2-12	-----	
1-2-2	S09640009	1	タチキヤクLクミ	-----	
1-2-2-1	S09221002	1	テーブルササエL	-----	
1-2-2-2	S09222102	1	ソトアシL	-----	
1-2-2-3	017081606	3	ホルト8X16	-----	
1-2-2-4	028080246	3	ハネサガネ2-8	-----	
1-2-2-5	S09312001	3	ヒラサガネダイ8	-----	
1-2-2-6	S05223001	2	キヤスター	-----	
1-2-2-7	022120306	2	ナツト3シユ12	-----	
1-2-2-8	S10661109	2	ソトアシフタコム	-----	
1-2-2-9	026120236	2	ヒラサガネミガキ12	-----	
1-2-2-10	028120246	2	ハネサガネ2-12	-----	
1-2-3	S43672209	1	ハリ	-----	
1-2-4	017081606	4	ホルト8X16	-----	
1-2-5	028080246	4	ハネサガネ2-8	-----	
1-2-6	025080236	4	ヒラサガネチユウ8	-----	
1-2-7	S09224002	1	フミイタササエダイ	-----	
1-2-8	S09225001	2	4カクナツト	-----	
1-2-9	017081606	2	ホルト8X16	-----	
1-2-10	028080246	2	ハネサガネ2-8	-----	
1-2-11	S09226001	2	フミイタササエサガネ	-----	
1-3	133172003	1	アブラサシダイ	-----	
1-4	037521016	1	+ナヘタツピン 2シユ5	-----	
1-5	025050236	1	ヒラサガネチユウ5	-----	
1-6	028050246	1	ハネサガネ2-5	-----	
1-7	S15158009	1	コモノケース	-----	
1-8	S02740000	1	フエルト	-----	
1-9	S02739000	1	ゴムシヤクテープ	-----	
1-10	039411215	2	トラスタツピン4X12	-----	
1-11	119702004	1	ヨコヒキダシ	-----	
1-12	101073001	1	ヒキダシコテイハネ	-----	
1-13	101121000	2	ヨコヒキダシササエ	-----	
1-14	032361306	4	+マルモクネジ 3.5X13	-----	
1-15	133180005	4	+マルモクネジ 6.2X38	-----	
			<電磁式用>	<For Solenoid type>	
2	S55206001	1	オサエアケレンカン	-----	

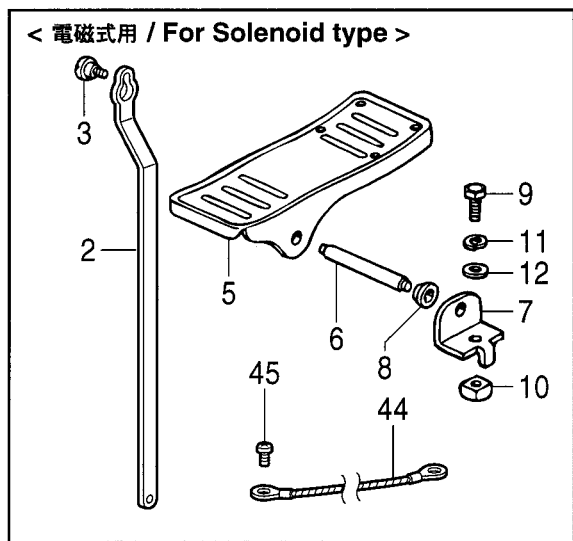
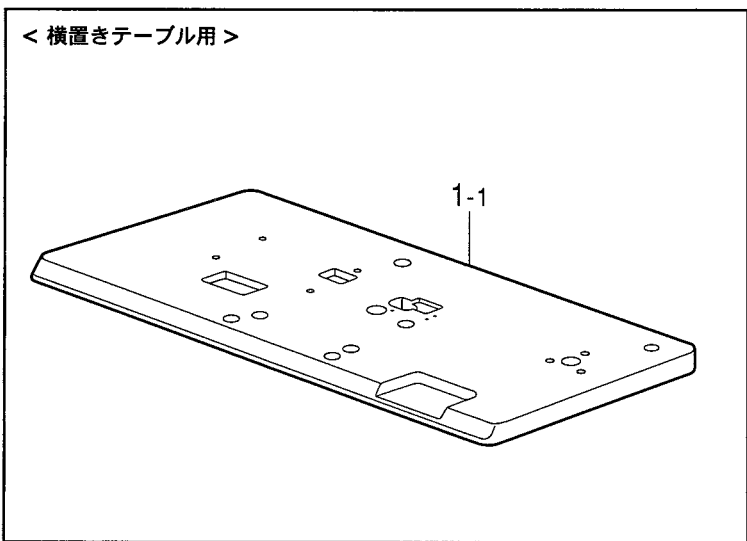
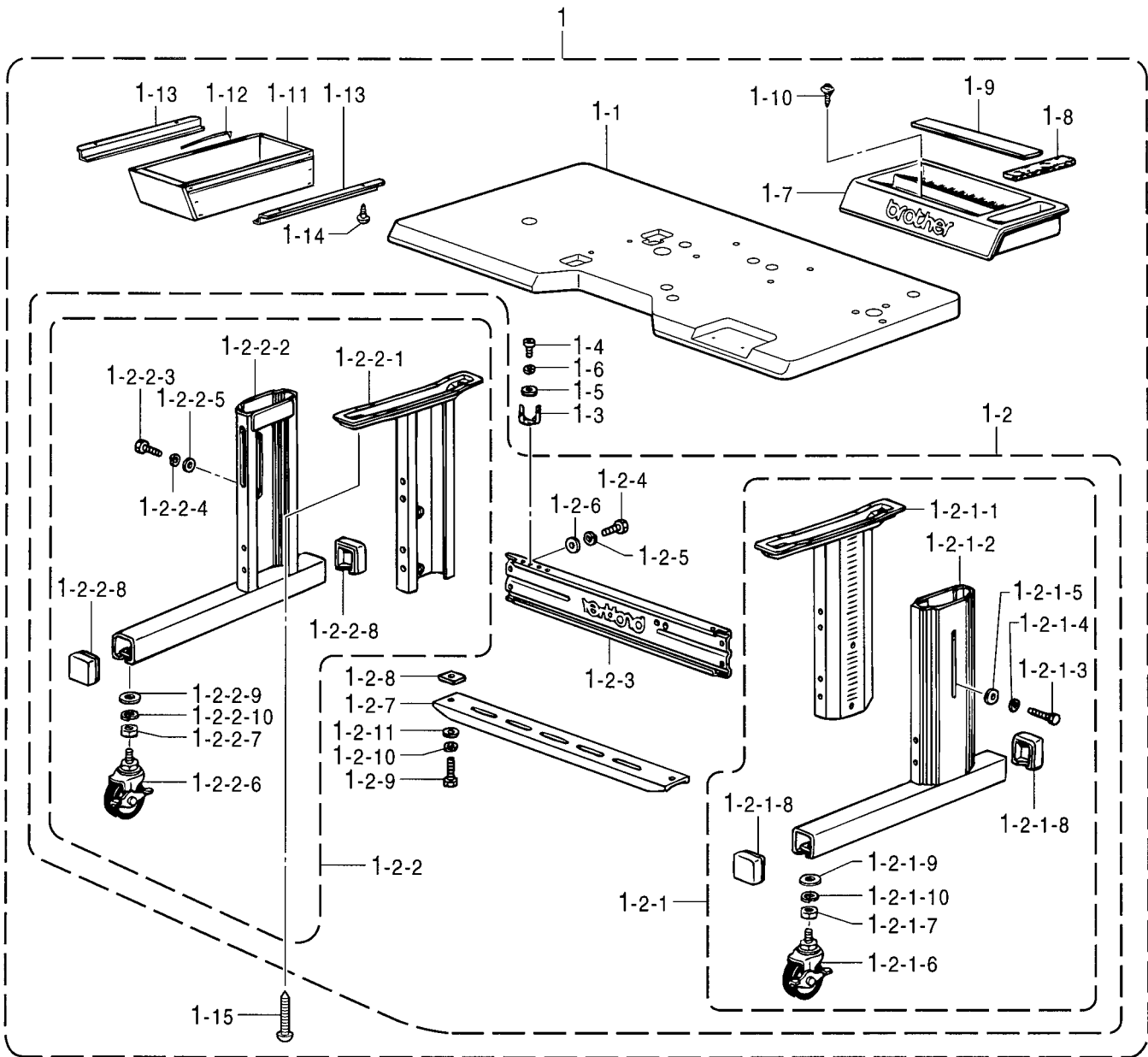

W.動力台関係 / Power table

REF.NO	CODE	Q'TY	品名	NAME OF PARTS	RM
			<電磁式用>	<For Solenoid type>	
3	115559002	1	ダンネジ4.76	-----	
5	S01199003	1	オサエアケフミイタ	-----	
6	133188001	1	オサエアケフミイタジク	-----	
7	119707003	2	フミイタジクウケ	-----	
8	119708001	2	フミイタジクウケカラー	-----	
9	017082206	2	ホルト8X22	-----	
10	116694001	2	4カクナツト8	-----	
11	028080240	2	ハネサガネ2-8	-----	
12	025080236	2	ヒラサガネチユウ8	-----	
44	S58200000	1	アースセン	-----	
45	037521016	1	+ナヘタツピン 2シユ5	-----	

X. ワンタッチ押え装置関係 (オプション部品) / One-touch work clamp (Option parts)

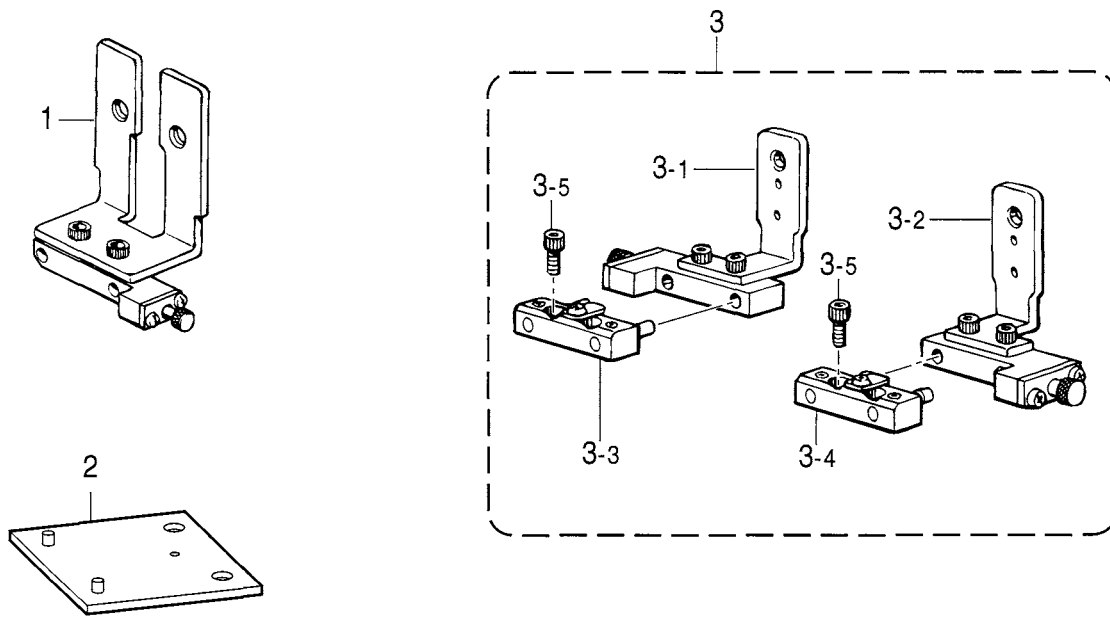

< 補給用部品 / For supply parts >

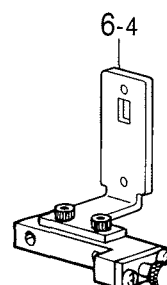
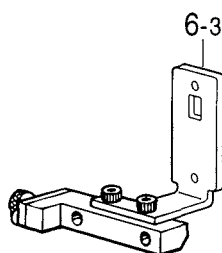
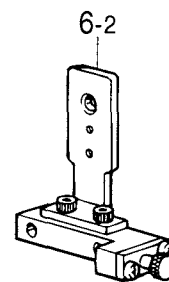
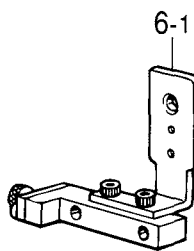
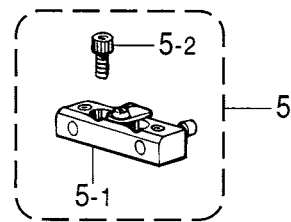
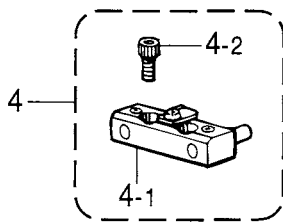

X.ワンタッチ押え装置関係 (オプション部品) / One-touch work clamp (Option parts)

REF.NO	CODE	Q'TY	品名	NAME OF PARTS	RM
1	S24612001	1	<スナップ、ホック付用> ワンタッチオサエUNクミ	<For Attaching the snap & hook> ONE-TOUCH HOLDER ASSY, UN	※
2	S57952001	1	OTオクリイタダイクミ	OT-FEED PLATE BRACKET ASSY	
3	S44794001	1	<ワンタッチ押え装置> ワンタッチオサエソウチセット	<For One-touch work clamp set> ONE-TUOCH WORK CLAMP SET	※
3-1	S20280101	1	ワンタッチオサエLクミ	ONE-TOUCH HOLDER ASSY, L	※
3-2	S20286101	1	ワンタッチオサエRクミ	ONE-TOUCH WORK CLAMP R ASSY	※
3-3	S20289101	2	ジクホルダー-Lクミ	WORK CLAMP HOLDER ASSY, L	※
3-4	S20293101	2	ジクホルダー-Rクミ	WORK CLAMP HOLDER ASSY, R	※
3-5	S59890001	8	アナホルト437-40X8	BOLT, SOCKET SM4.37-40X8	
4	S20822101	1	<補給用部品> ジクホルダー-Lセット	<For Supply parts> WORK CLAMP HOLDER SET, L	※
4-1	S20289101	1	ジクホルダー-Lクミ	WORK CLAMP HOLDER ASSY, L	※
4-2	S59890001	2	アナホルト437-40X8	BOLT, SOCKET SM4.37-40X8	
5	S20823101	1	ジクホルダー-Rセット	WORK CLAMP HOLDER SET, R	※
5-1	S20293101	1	ジクホルダー-Rクミ	WORK CLAMP HOLDER ASSY, R	※
5-2	S59890001	2	アナホルト437-40X8	BOLT, SOCKET SM4.37-40X8	
6-1	S20280101	1	<311F-0, 311F-L用> ワンタッチオサエLクミ	<For 311F-0 & 311F-L> ONE-TOUCH HOLDER ASSY, L	※
6-2	S20286101	1	ワンタッチオサエRクミ	ONE-TOUCH WORK CLAMP R ASSY	※
6-3	S57955001	1	<326F-0用> ワンタッチオサエLクミ	<For 326F-0> ONE-TOUCH HOLDER ASSY, L	※
6-4	S57957001	1	ワンタッチオサエRクミ	ONE-TOUCH HOLDER ASSY, R	※

BAS-311F-0-941

☆RM欄に※が付いている部品は、精密な組み立て調整がして有りますので絶対に分解しないで下さい。

☆Parts which have an asterisk(※)in the RM colum are parts which have been assembled and adjusted to high precisions.
These parts should never be disassembled.

Y1. 中押し反転装置関係(311F-0, 311F-Lオプション部品) /
Inner clamping device (Option parts of 311F-0, 311F-L)

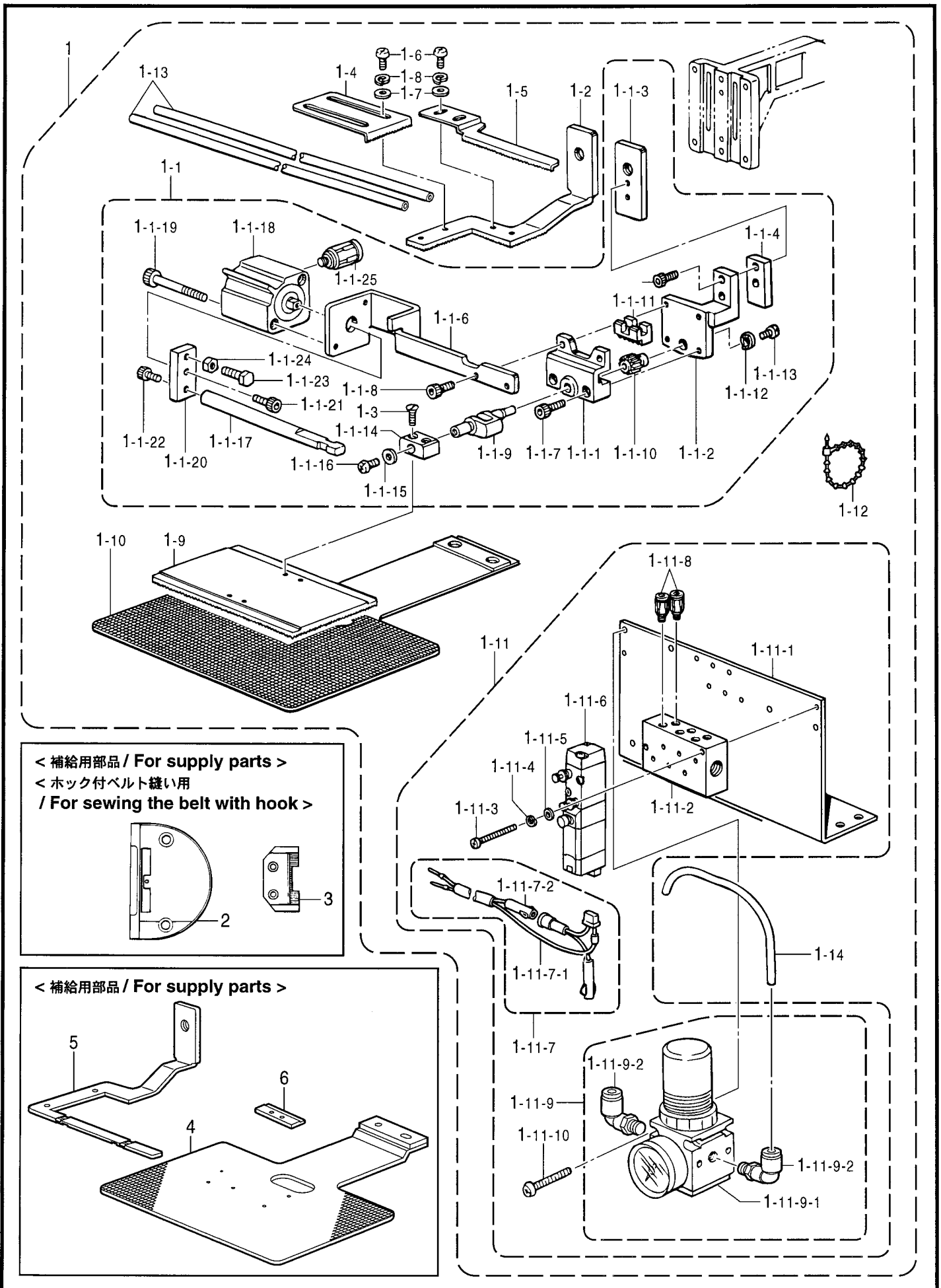

BAS-311F-0-943

Y1.中押え反転装置関係 (311F-0, 311F-L オプション部品) /

Inner clamping device (Option parts of 311F-0, 311F-L)

REF.NO	CODE	QTY	品名	NAME OF PARTS	RM
1	S44793009	1	ネームツケハンテンスウチセット	INNER CLAMPING DEVICE SET	
1-1	S12633209	1	オサエクランクLAクミ	WORK CLAMP CRANK ASSY, LA	
1-1-1	S12634009	1	オサエクランクホルダA	WORK CLAMP CRANK HOLDER, A	
1-1-2	S12635009	1	オサエクランクホルダB	WORK CLAMP CRANK HOLDER, B	
1-1-3	S12636001	1	オサエクランクホルダC	WORK CLAMP CRANK HOLDER, C	
1-1-4	S12641009	1	クランクホルダカンザ	SPACER, CRNK HOLDER	
1-1-5	S59894001	2	アナホルト437-40X12	BOLT, SOCKET SM4.37-40X12	
1-1-6	S12638009	1	ハンテンスリンダダイ	REVERSE CYLINDER BASE	
1-1-7	018301236	2	アナホルト3X12	BOLT, SOCKET M3X12	
1-1-8	018301036	2	アナホルト3X10	BOLT, SOCKET M3X10	
1-1-9	S05665001	1	オサエクランクLA	WORK CLAMP CRANK, LA	
1-1-10	154235001	1	ハンテッキヤ	REVERSE GEAR	
1-1-11	154236001	1	ハンテラツク	REVERSE RACK	
1-1-12	145087001	1	ハンテッキヤサガネ	WASHER	
1-1-13	149831101	1	アタマツキトメネジ3.18	SET SCREW, SM3.18	
1-1-14	154237001	1	オサエイタホルダL	WORK CLAMP PLATE HOLDER, L	
1-1-15	025350132	1	ヒラサガネシヨウ	WASHER, PLAIN S 3.5	
1-1-16	100242003	1	シメネジ3.57	SCREW, SM3.57-40X5	
1-1-17	S12637009	1	ハンテロツト	REVERSE ROD	
1-1-18	S12639001	1	ハンテンスリンダ	REVERSE CYLINDER	
1-1-19	S12642009	2	アナホルト3X35	BOLT, SOCKET M3X35	
1-1-20	S12640009	1	ハンテングツキテ	JOINT	
1-1-21	018300836	1	アナホルト3X8	BOLT, SOCKET M3X8	
1-1-22	018300836	1	アナホルト3X8	BOLT, SOCKET M3X8	
1-1-23	017501216	1	ホルト5X12	BOLT, M5X12	
1-1-24	021500216	1	2シュナツト5	NUT, 2 M5	
1-1-25	S18415101	2	ハーフユニオンQ4M5	HALF UNION :Q4M5	
1-2	S12643001	1	ソトオサエアシ312-1	OUTER WORK CLAMP, 312-1	
1-3	117291002	2	サラネジ3.18	SCREW, FLAT SM3.18	
1-4	154252001	1	イチキメイタL	POSITIONING PLATE, L	
1-5	154253001	1	イチキメイタR	POSITIONING PLATE, R	
1-6	062670512	4	ナヘコ357-40X5	SCREW, PAN SM3.57-40X5	
1-7	025350332	4	ヒラサガネダイ3.5	WASHER, PLAIN L 3.5	
1-8	028350242	4	ハネサガネ2-3.5	WASHER, SPRING 2-3.5	
1-9	154256101	1	オサエイタブランクA	WORK CLAMP PLATE BLANK, A	
1-10	S12645001	1	オクリイタブランク312-1	FEED PLATE BLANK, 312-1	
1-11	S44745109	1	ハンテバルブ3クミ	INNER VALVE ASSY, 3	
1-11-1	S31570409	1	バルブトリツケイタ4-5H	VALVE SETTING PLATE, 4-5H	
1-11-2	S44748001	1	エアマニホルト3	AIR MANIFOLD, 3	
1-11-3	062302505	2	ナヘコ3X25	SCREW, PAN M3X25	
1-11-4	028030242	2	ハネサガネ2-3	WASHER, SPRING 2-3	
1-11-5	025030232	2	ヒラサガネチユウ3	WASHER, PLAIN M 3	
1-11-6	S43683001	1	デンジバルブ	SOLENOID VALVE	
1-11-7	S43696100	1	バルブハーネスX1クミ	VALVE HARNESS ASSY, X1	
1-11-7-1	S44746100	1	ツイカバルブハーネス	VALVE HARNESS	
1-11-7-2	S44750100	1	ツイカバルブハーネス24V	VALVE HARNESS, 24V	
1-11-8	S18415101	2	ハーフユニオンQ4M5	HALF UNION :Q4M5	
1-11-9	S45252000	1	レギュレータクミ	REGULATOR ASSY	
1-11-9-1	S45253000	1	レギュレータ	REGULATOR	
1-11-9-2	S45254000	2	ツキテ3109-4-10	JOINT, 3109-4-10	
1-11-10	062404005	2	ナヘコ4X40	SCREW, PAN M4X40	
1-12	340400001	2	ユニタイバンド	BEAD BAND	
1-13	S03803000	2	ナイロンチューブ	AIR TUBE, 4 L=1300	
1-14	S28741000	1	エアチューブ	AIR TUBE, 4 L=300	
			“補給用部品” ＜ホック付ベルト縫い用＞	“For Supply parts” ＜For Sewing the belt with hook＞	
2	S13099001	1	ハリイタH	NEEDLE PLATE, H	
3	S13100001	1	オクリバH	FEED DOG, H	
4	S14598001	1	OTオクリイタブランク312	OT FEED PLATE BLANK, 312	
5	S12644001	1	ソトオサエアシ312-2	OUTER WORK CLAMP, 312-2	
6	S10542001	1	ナカオサELL	INNER CLAMP, LL	

Y2 . 中押し反転装置関係(326F-0オプション部品) /
 Inner clamping device (Option parts of 326F-0)

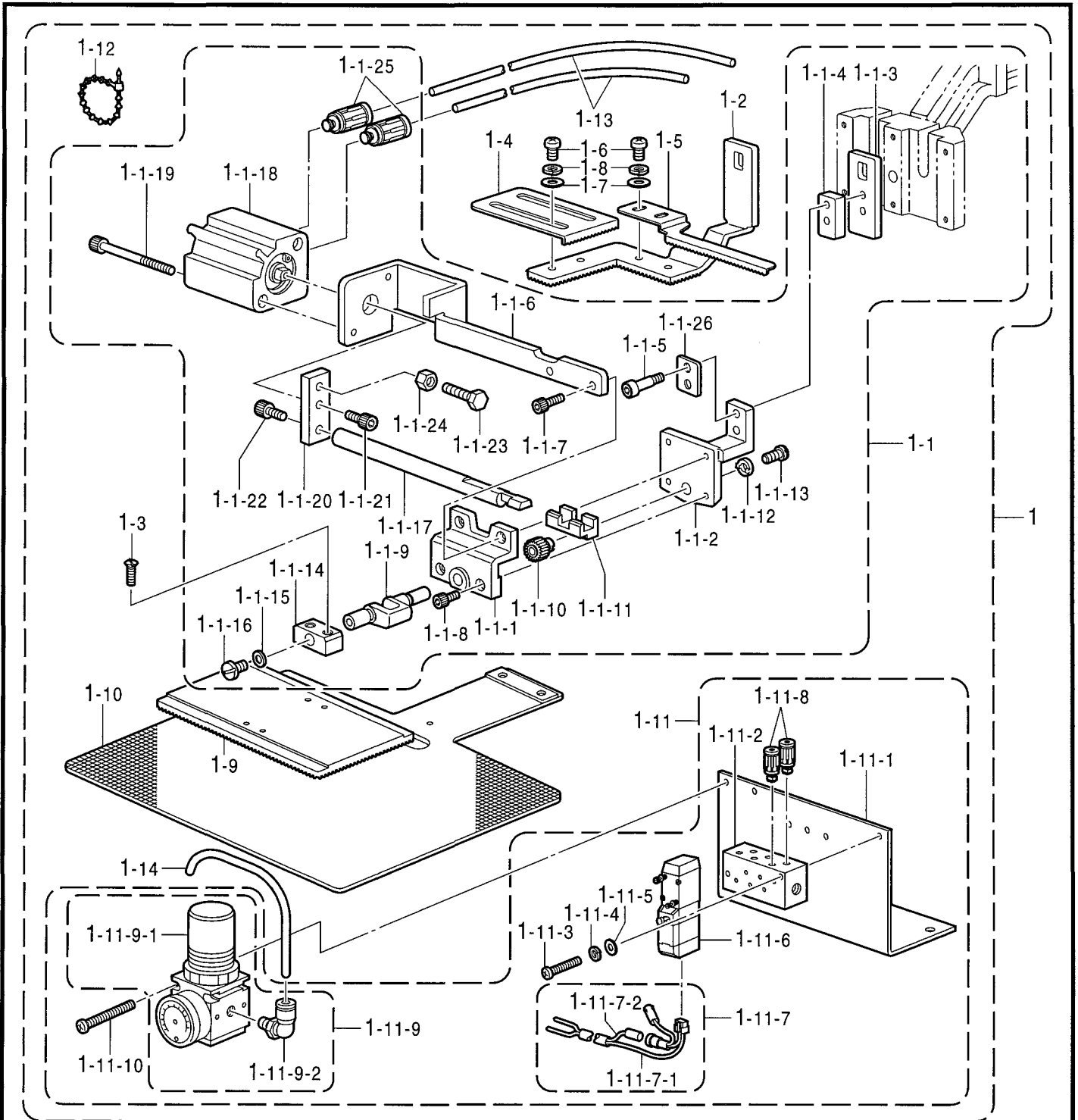

< 補給用部品 / For supply parts >

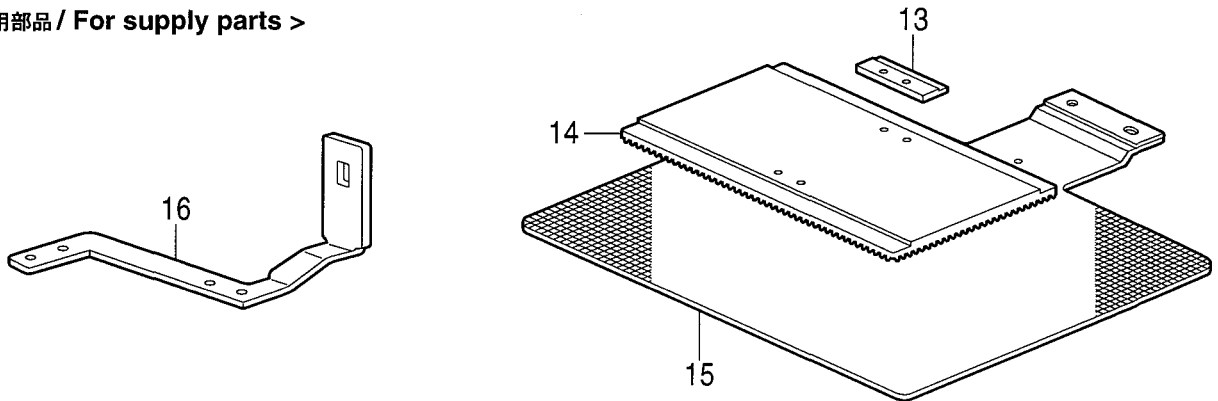

Y2.中押え反転装置関係 (326F-0 オプション部品) /
Inner clamping device (Option parts of 326F-0)

REF.NO	CODE	QTY	品名	NAME OF PARTS	RM
1	S57851001	1	ネームツケハンテンスウチセット	INNER CLAMPING DEVICE SET,326F	
1-1	S57853001	1	オサエクランクLAクミ	WORK CLAMP CRANK ASSY, LA	
1-1-1	S12634009	1	オサエクランクホルダA	WORK CLAMP CRANK HOLDER, A	
1-1-2	S12635009	1	オサエクランクホルダB	WORK CLAMP CRANK HOLDER, B	
1-1-3	S57854001	1	オサエクランクホルダC	WORK CLAMP HOLDER, C	
1-1-4	S57855001	1	クランクホルダカンサ	SPACER	
1-1-5	150382001	2	アナホルト4.37X18	BOLT, SOCKET SM4.37X18	
1-1-6	S12638009	1	ハンテンスリンダダイ	REVERSE CYLINDER BASE	
1-1-7	018301236	2	アナホルト3X12	BOLT, SOCKET M3X12	
1-1-8	018301036	2	アナホルト3X10	BOLT, SOCKET M3X10	
1-1-9	S05665001	1	オサエクランクLA	WORK CLAMP CRANK, LA	
1-1-10	154235001	1	ハンテングキヤ	REVERSE GEAR	
1-1-11	154236001	1	ハンテングラック	REVERSE RACK	
1-1-12	145087001	1	ハンテングキヤサガネ	WASHER	
1-1-13	149831101	1	アタマツキトメネジ3.18	SET SCREW, SM3.18	
1-1-14	154237001	1	オサエイタホルダL	WORK CLAMP PLATE HOLDER, L	
1-1-15	025350132	1	ヒラサガネシヨウ	WASHER, PLAIN S 3.5	
1-1-16	100242003	1	シメネジ3.57	SCREW, SM3.57-40X5	
1-1-17	S12637009	1	ハンテングロツド	REVERSE ROD	
1-1-18	S12639001	1	ハンテンスリンダ	REVERSE CYLINDER	
1-1-19	S12642009	2	アナホルト3X35	BOLT, SOCKET M3X35	
1-1-20	S12640009	1	ハンテングツギテ	JOINT	
1-1-21	018300836	1	アナホルト3X8	BOLT, SOCKET M3X8	
1-1-22	018300836	1	アナホルト3X8	BOLT, SOCKET M3X8	
1-1-23	017501216	1	ホルト5X12	BOLT, M5X12	
1-1-24	021500216	1	2シユナツト5	NUT, 2 M5	
1-1-25	S18415101	2	ハーフユニオンQ4M5	HALF UNION :Q4M5	
1-1-26	S44424001	1	クランクホルダスペース	SPACER, CRANK HOLDER	
1-2	S57856001	1	ソトオサエアシ326F-1	OUTER WORK CLAMP, 326F-1	
1-3	117291002	2	サラネジ3.18	SCREW, FLAT SM3.18	
1-4	S57859001	1	イチキメイトL	POSITIONING PLATE, L	
1-5	S57860001	1	イチキメイトR	POSITIONING PLATE, R	
1-6	062670512	4	ナベコ357-40X5	SCREW, PAN SM3.57-40X5	
1-7	025350332	4	ヒラサガネダイ3.5	WASHER, PLAIN L 3.5	
1-8	028350242	4	ハネサガネ2-3.5	WASHER, SPRING 2-3.5	
1-9	154256101	1	オサエイタブランクA	WORK CLAMP PLATE BLANK, A	
1-10	S57858001	1	オクリイタブランクH	FEED PLATE BLANK, H	
1-11	S44745109	1	ハンテングバルブ3クミ	INNER VALVE ASSY, 3	
1-11-1	S31570409	1	バルブトリツケイタ4-5H	VALVE SETTING PLATE, 4-5H	
1-11-2	S44748001	1	エアマニホルド3	AIR MANIFOLD, 3	
1-11-3	062302505	2	ナベコ3X25	SCREW, PAN M3X25	
1-11-4	028030242	2	ハネサガネ2-3	WASHER, SPRING 2-3	
1-11-5	025030232	2	ヒラサガネチユウ3	WASHER, PLAIN M 3	
1-11-6	S43683001	1	テングバルブ	SOLENOID VALVE	
1-11-7	S43696100	1	バルブハーネスX1クミ	VALVE HARNESS ASSY, X1	
1-11-7-1	S44746100	1	ツイカバルブハーネス	VALVE HARNESS	
1-11-7-2	S44750100	1	ツイカバルブハーネス24V	VALVE HARNESS, 24V	
1-11-8	S18415101	2	ハーフユニオンQ4M5	HALF UNION :Q4M5	
1-11-9	S45252000	1	レギュレータクミ	REGULATOR ASSY	
1-11-9-1	S45253000	1	レギュレータ	REGULATOR	
1-11-9-2	S45254000	2	ツギテ3109-4-10	JOINT, 3109-4-10	
1-11-10	062404005	2	ナベコ4X40	SCREW, PAN M4X40	
1-12	340400001	2	ユニタイバンド	BEAD BAND	
1-13	S03803000	2	ナイロンチューブ	AIR TUBE, 4 L=1300	
1-14	S28741000	1	エアチューブ	AIR TUBE, 4 L=300	
			<補給用部品>	<For Supply parts>	
13	S10542001	1	ナカオサELL	INNER CLAMP, LL	
14	S51077001	1	オサエイタブランクA326L	WORK CLAMP BLANK, A 326L	
15	S51078101	1	OTオクリイタブランクLH	OT-FEED PLATE BLANK, H :326L	
16	S57857001	1	ソトオサエアシ326F-3	OUTER WORK CLAMP, 326F-3	

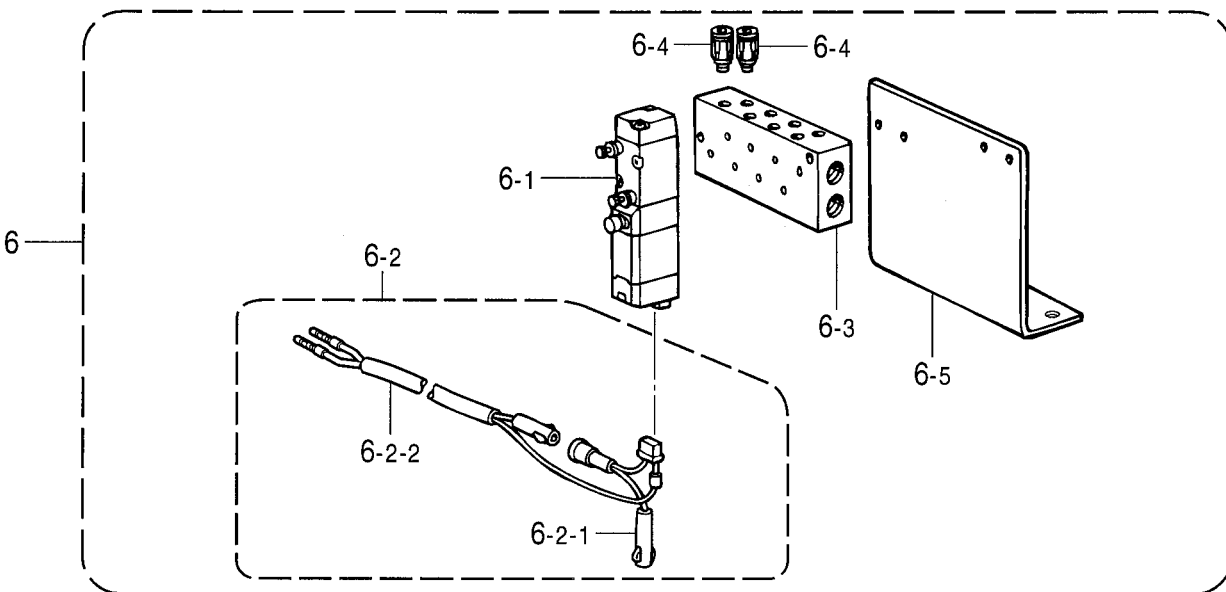
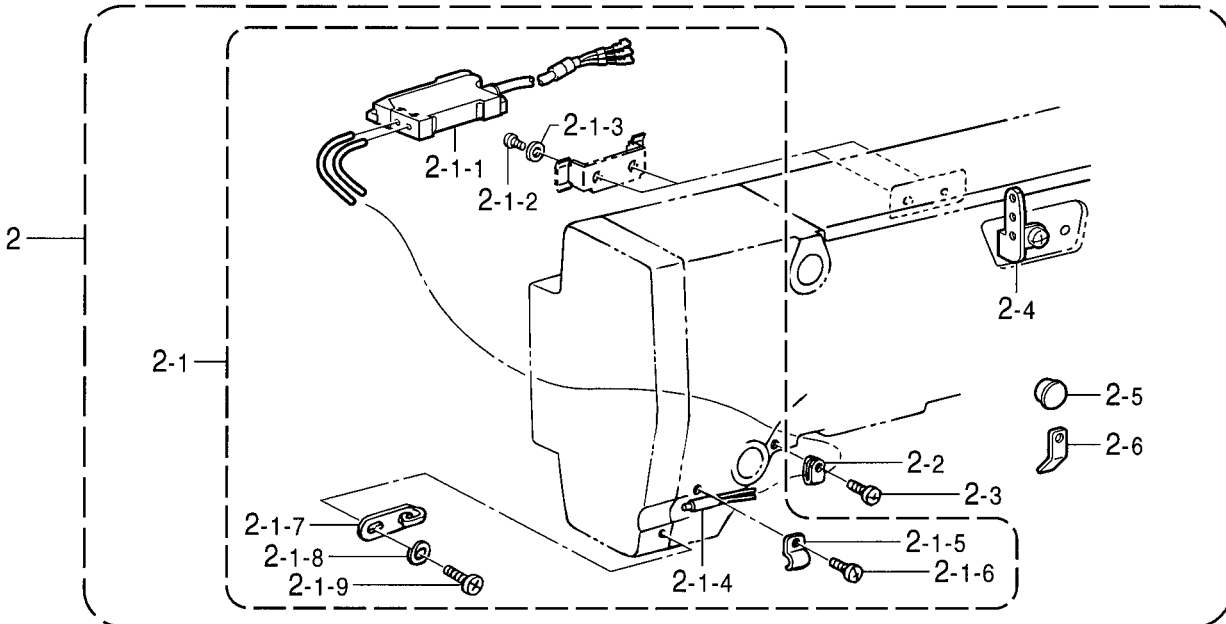
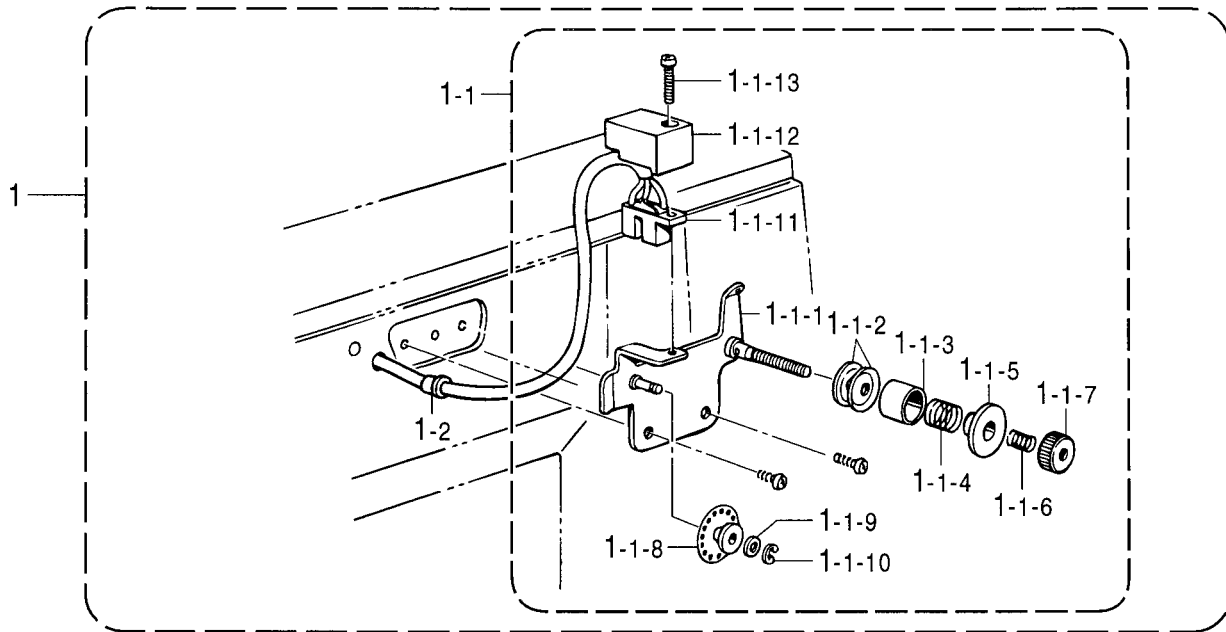

AA1.補助装置関係 (オプション部品) / Auxiliary device (Option parts)

REF.NO	CODE	Q'TY	品名	NAME OF PARTS	RM
			“糸切れ感知装置”	“Thread breakage detector”	
			<プリー式>	<Rotary-type>	
1	S43833109	1	トキレカンチソウチセットR	TR. BREAKAGE DETECTOR SET, R	
1-1	S43834109	1	ロータリートキレカンチクミ	TR. BREAKAGE DETECTOR ASSY, R	
1-1-1	S18032001	1	トキレカンチブラケットクミ	DETECTOR BRACKET ASSY	
1-1-2	144504001	2	トアンナイサラ	THREAD GUIDE DISC	
1-1-3	146206009	1	トアンナイサラオサエ	DISC PRESSER, T-GUIDE	
1-1-4	146058001	1	プレテンションハネ	PRE-TENSION SPRING	
1-1-5	146059001	1	プレテンションナット	PRE-TENSION NUT	
1-1-6	146060000	1	ナットオシハネ	SPRING	
1-1-7	155510001	1	トチヨウシナット	TENSION NUT	
1-1-8	157255100	1	プリー-A	PULLEY, A	
1-1-9	025030135	1	ヒラサガネシヨウ3	WASHER, PLAIN S 3	
1-1-10	048020342	1	トメワE2	RETAINING RING, E2	
1-1-11	S43835100	1	トキレフォトセンサークミ	SENSOR ASSY	
1-1-12	S18037009	1	センサーカバー	SENSOR COVER	
1-1-13	062301616	1	ナベコM3X16	SCREW, PAN M3X16	
1-2	146080000	1	コードブシ	CORD BUSH	
			<ビームセンサー式>	<Beam-type>	
2	S43836301	1	トキレカンチソウチセットF	TR. BRAKEAGE DETECTOR SET, F	
2-1	S43977201	1	トキレカンチFクミ	TR. BRAKEAGE DETECTOR ASSY, F	
2-1-1	S43279300	1	アンプユニット	AMPLIFIRE UNIT	
2-1-2	062300612	2	ナベコ3X6	SCREW, PAN M3X6	
2-1-3	025030232	2	ヒラサガネチユウ3	WASHER, PLAIN M 3	
2-1-4	S29468100	1	ファイバユニットN	FIBER UNIT, N	
2-1-5	S11884001	1	センサートリツケイタ	SENSOR SETTING PLATE	
2-1-6	062300612	1	ナベコ3X6	SCREW, PAN M3X6	
2-1-7	S02617001	1	メンイタトアンナイ	FACE PLATE THREAD GUIDE	
2-1-8	028350242	1	ハネサガネ2-3.5	WASHER, SPRING 2-3.5	
2-1-9	060670612	1	ハイント357-40X6	SCREW, BIND SM3.57-40X6	
2-2	625010000	1	ナイロンクランプNK-2N	NYLON CLAMP NK-2N	
2-3	060670612	1	ハイント357-40X6	SCREW, BIND SM3.57-40X6	
2-4	152889001	1	ミツメイトカケ	THREAD RETAINER	
2-5	117936001	2	ゴムセン9.4	RUBBER CAP, 9.4	
2-6	S02657101	1	コードオサエ	CORD HOLDER	
			<追加バルブセット>	<Addition valve set>	
6	S43847201	1	デンジバルブOP4クミ	SOLENOID VALVE ASSY, OP4	
6-1	S43683001	1	デンジバルブ	SOLENOID VALVE	
6-2	S43696100	1	バルブハーネスX1クミ	VALVE HARNESS ASSY, X1	
6-2-1	S44746100	1	ツイカバルブハーネス	VALVE HARNESS	
6-2-2	S44750100	1	ツイカバルブハーネス24V	VALVE HARNESS, 24V	
6-3	S44749001	1	エアマニホルド4	AIR MANIFOLD, 4	
6-4	S18415101	2	ハーフユニオンQ4M5	HALF UNION :Q4M5	
6-5	S31554109	1	バルブトリツケイタ4-5	SETTING PLATE, 4-5 :VALVE	

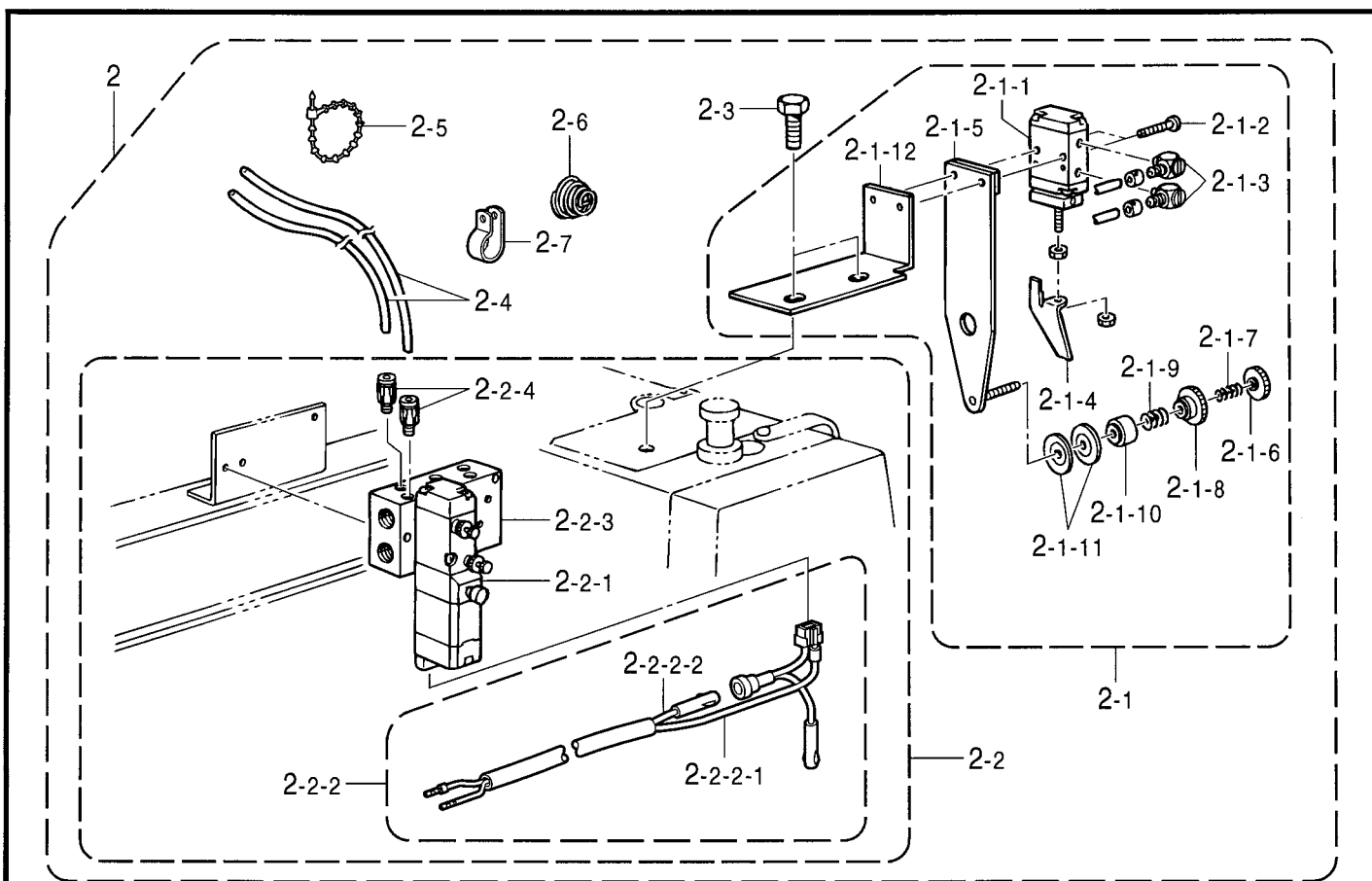

" ソフト押えセット / Soft work clamp set "

< 311F-0, 311F-L 用 / For 311F-0 & 311F-L >

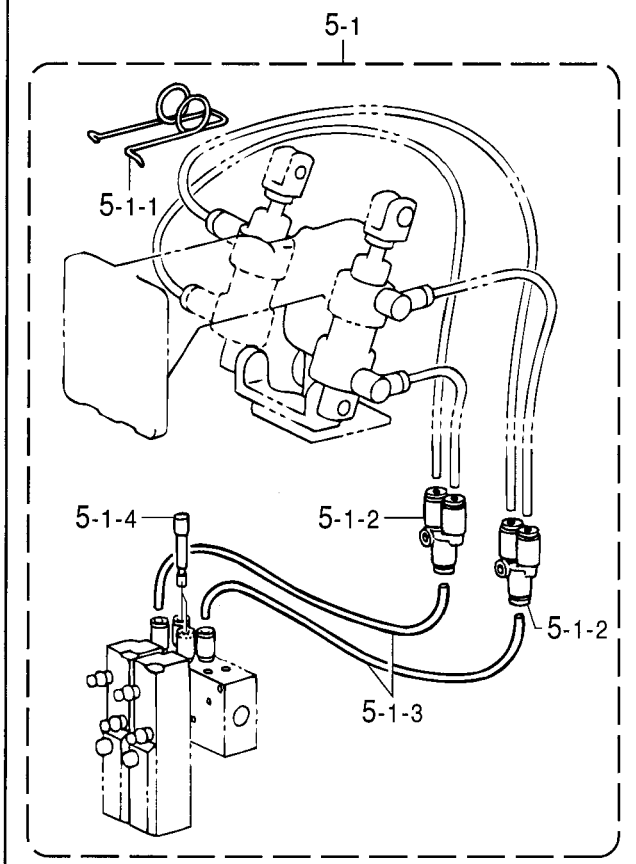

< 326F-0 用 / For 326F-0 >

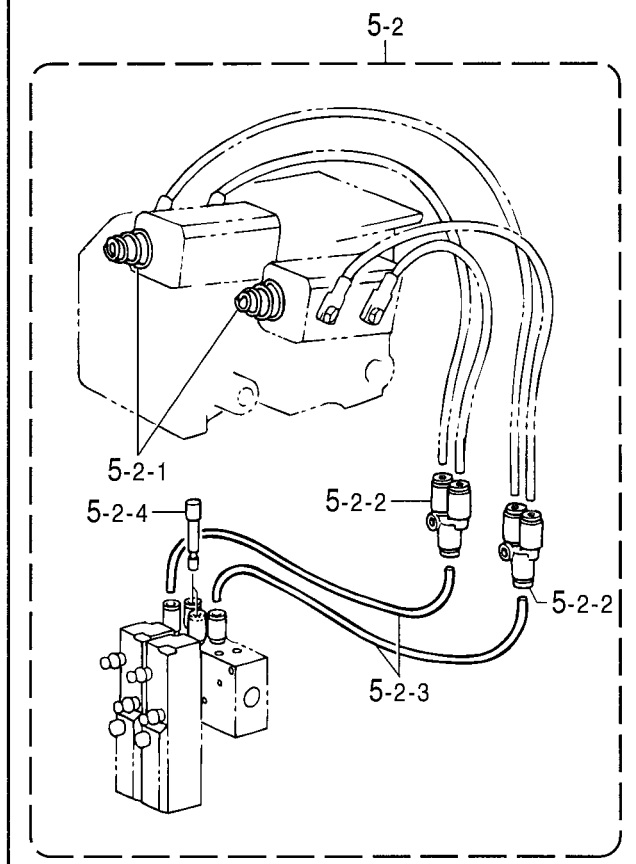

AA2.補助装置関係 (オプション部品) / Auxiliary device (Option parts)

REF.NO	CODE	Q'TY	品名	NAME OF PARTS	RM
			<2段系調子装置>	<2-step tension device>	
2	S43837101	1	2ダンTソウチセット1	2-STEP THREAD TENSION DEVICE	
2-1	S43838101	1	2ダンテンションクミ	2-STEP THREAD TENSION ASSY	
2-1-1	S34706000	1	エア-シリンダ10X10	AIR CYLINDER, 10X10	
2-1-2	018302032	2	アナホルト3X20	SCREW 3X20	
2-1-3	S12150000	2	ホ-スエルホM-5HL-4	TUBE ELBOW, M-5HL-4	
2-1-4	S34533001	1	サラワリツメ	COUNTERSINK CLAW	
2-1-5	S34534101	1	サブテンションダイクミ	SUB TENSION BRACKET ASSY	
2-1-6	155510001	1	イトチヨウシナツト	TENSION NUT	
2-1-7	146060000	1	ナツトオシハネ	SPRING	
2-1-8	146059001	1	プレテンションナツト	PRE-TENSION NUT	
2-1-9	146058001	1	プレテンションハネ	PRE-TENSION SPRING	
2-1-10	146206009	1	イトアンナイサラオサエ	DISC PRESSER, T-GUIDE	
2-1-11	144504001	2	イトアンナイサラ	THREAD GUIDE DISC	
2-1-12	S34536101	1	シリンダ-トリツケイタ	SETTING BRACKET, CYLINDER	
2-2	S43839105	1	テンジバルブOP3クミ	SOLENOID VALVE OP3 ASSY	
2-2-1	S43683001	1	テンジバルブ	SOLENOID VALVE	
2-2-2	S43696100	1	バルブハ-ネスX1クミ	VALVE HARNESS ASSY, X1	
2-2-2-1	S44746100	1	ツイカバルブハ-ネス	VALVE HARNESS	
2-2-2-2	S44750100	1	ツイカバルブハ-ネス24V	VALVE HARNESS, 24V	
2-2-3	S44748001	1	エアマニホルト3	AIR MANIFOLD, 3	
2-2-4	S18415101	2	ハ-フユニオンQ4M5	HALF UNION :Q4M5	
2-3	017821813	2	ホルト7.94X18	BOLT, SM7.94X18	
2-4	S15031008	2	エア-チューブ	AIR TUBE, 4X2.5 L=1900	
2-5	340400001	5	ユニタイバンド	BEAD BAND	
2-6	104525001	1	イトチヨウシハネ	TENSION SPRING	
2-7	149287000	3	ナイロンクランプ	CORD HOLDER, 7N	
			"ソフト押えセット"	"Soft work clamp set"	
			<311F-0, 311F-L用>	<For 311F-0 & 311F-L>	
5-1	S43979001	1	ソフトオサエセット	SOFT WORK CLAMP SET	
5-1-1	S43980001	1	ソフトオサエハネ	SPRING	
5-1-2	S12104000	2	ユニオンワイ4	UNION, Y 4	
5-1-3	S08140000	2	エア-ホ-スS-C	AIR TUBE, 4 L=200	
5-1-4	S04897000	2	プラグ4	PLUG, 4	
			<326F-0用>	<For 326F-0>	
5-2	S44450001	1	ソフトオサエセット	SOFT WORK CLAMP SET	
5-2-1	S44412001	2	ソフトオサエハネ	SPRING	
5-2-2	S12104000	2	ユニオンワイ4	UNION, Y 4	
5-2-3	S08140000	2	エア-ホ-スS-C	AIR TUBE, 4 L=200	
5-2-4	S04897000	2	プラグ4	PLUG, 4	

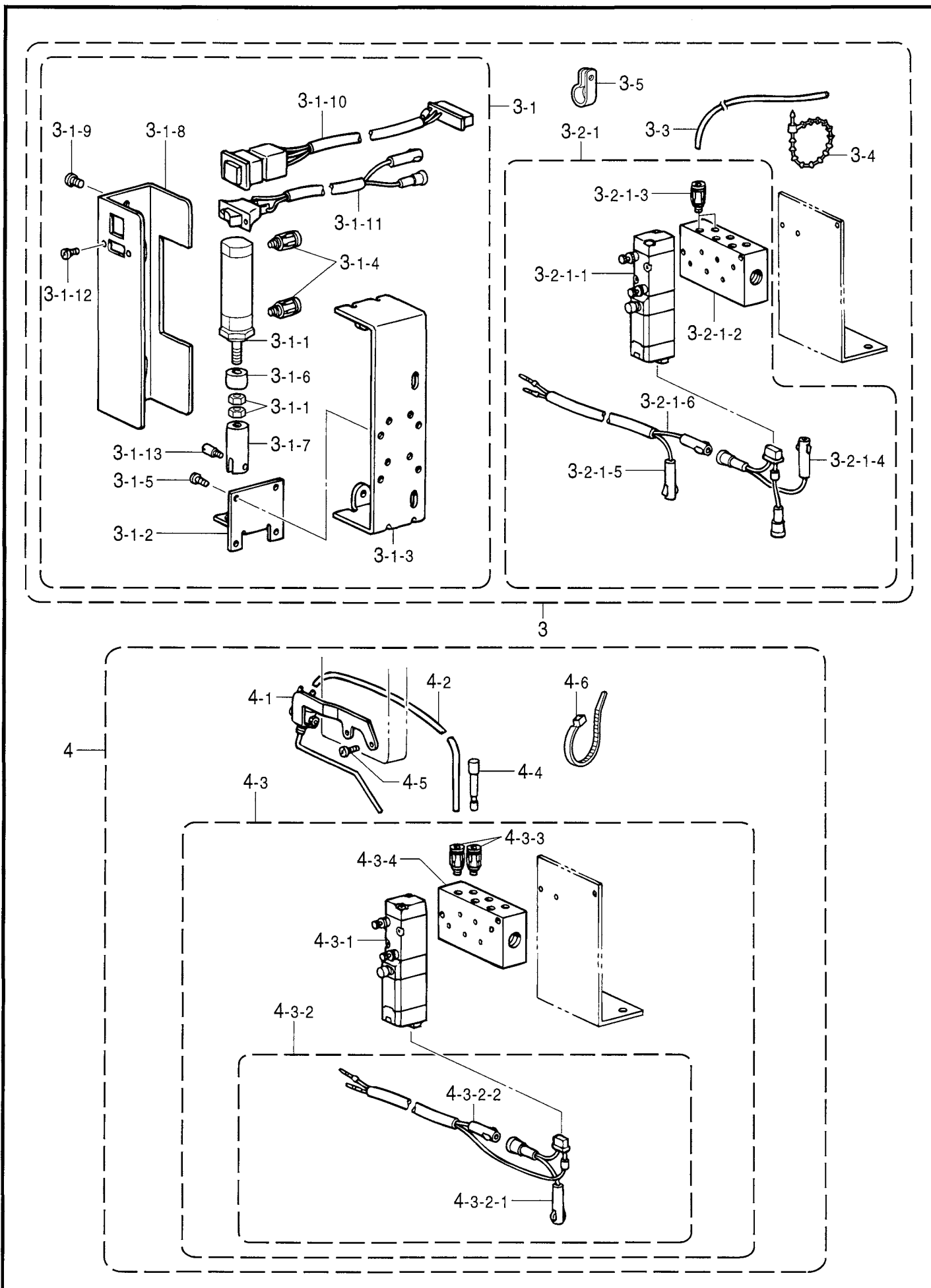

AA3.補助装置関係 (オプション部品) / Auxiliary device (Option parts)

REF.NO	CODE	Q'TY	品名	NAME OF PARTS	RM
			<エアワイパー装置>	< Thread wiper set : pneumatic type >	
3	S43841109	1	エアワイパーソウチクミ	TR. WIPER SET, PNEUMATIC TYPE	
3-1	S43842109	1	エアワイパークミ	TR. WIPER ASSY, PNEUMATIC TYPE	
3-1-1	S17942100	1	エアシリンダ	AIR CYLINDER	
3-1-2	S31777001	1	シリンダトリツケイタ	CYLINDER SUPPORT PLATE	
3-1-3	S10214109	1	ソレノイドトリツケイタ	SOLENOID SETTING PLATE	
3-1-4	S18415101	2	ハーフユニオンQ4M5	HALF UNION :Q4M5	
3-1-5	062670612	4	ナベコ357-40X6	SCREW, PAN SM3.57-40X6	
3-1-6	S31778000	1	シリンダーストツパ	STOPPER, CYLINDER	
3-1-7	S31779001	1	シリンダーツキテ	JOINT, CYLINDER	
3-1-8	S31776109	1	シリンダークカバー	CYLINDER COVER	
3-1-9	062680512	2	ナベコ437-40X5	SCREW, PAN SM4.37-40X5	
3-1-10	S43203000	1	EMスイッチクミ	EM-SWITCH ASSY	
3-1-11	S43843009	1	イトハライスイッチクミ	THREAD WIPER SWITCH ASSY	
3-1-12	062300612	2	ナベコ3X6	SCREW, PAN M3X6	
3-1-13	S02680001	1	プランジャピン	PLUNGER PIN	
3-2-1	S43844101	1	AWデンジバルブ3クミ	SOLENOID VALVE ASSY, AW-3	
3-2-1-1	S43683001	1	デンジバルブ	SOLENOID VALVE	
3-2-1-2	S44748001	1	エアマニホルド3	AIR MANIFOLD, 3	
3-2-1-3	S18415101	2	ハーフユニオンQ4M5	HALF UNION :Q4M5	
3-2-1-4	S44759000	1	AWバルブハーネスA	AW-VALVE HARNESS, A	
3-2-1-5	S44760100	1	AWバルブハーネスB	AW-VALVE HARNESS, B	
3-2-1-6	S44750100	1	ツイカバルブハーネス24V	VALVE HARNESS, 24V	
3-3	S15031008	2	エアチューブ	AIR TUBE, 4X2.5 L=1900	
3-4	340400001	7	ユニタイバンド	BEAD BAND	
3-5	149287000	4	ナイロンクランプ	CORD HOLDER, 7N	
			<ニードルクーラー装置>	< Needle cooler set >	
4	S43846009	1	ニードルクーラーソウチセット	NEEDLE COOLER SET	
4-1	S18027101	1	ニードルブロー	NEEDLE BLOWER	
4-2	S15031008	1	エアチューブ	AIR TUBE, 4X2.5 L=1900	
4-3	S43839108	1	デンジバルブOP3クミ	SOLENOID VALVE OP3 ASSY	
4-3-1	S43683001	1	デンジバルブ	SOLENOID VALVE	
4-3-2	S43696100	1	バルブハーネスX1クミ	VALVE HARNESS ASSY, X1	
4-3-2-1	S44746100	1	ツイカバルブハーネス	VALVE HARNESS	
4-3-2-2	S44750100	1	ツイカバルブハーネス24V	VALVE HARNESS, 24V	
4-3-3	S44748001	1	エアマニホルド3	AIR MANIFOLD, 3	
4-3-4	S18415101	2	ハーフユニオンQ4M5	HALF UNION :Q4M5	
4-4	S04897000	1	プラグ4	PLUG, 4	
4-5	062670812	2	ナベコ3.57-40X8	SCREW, PAN SM3.57-40X8	
4-6	228475000	3	ケツソクバンド1.9X80	CABLE TIE, 1.9X80	

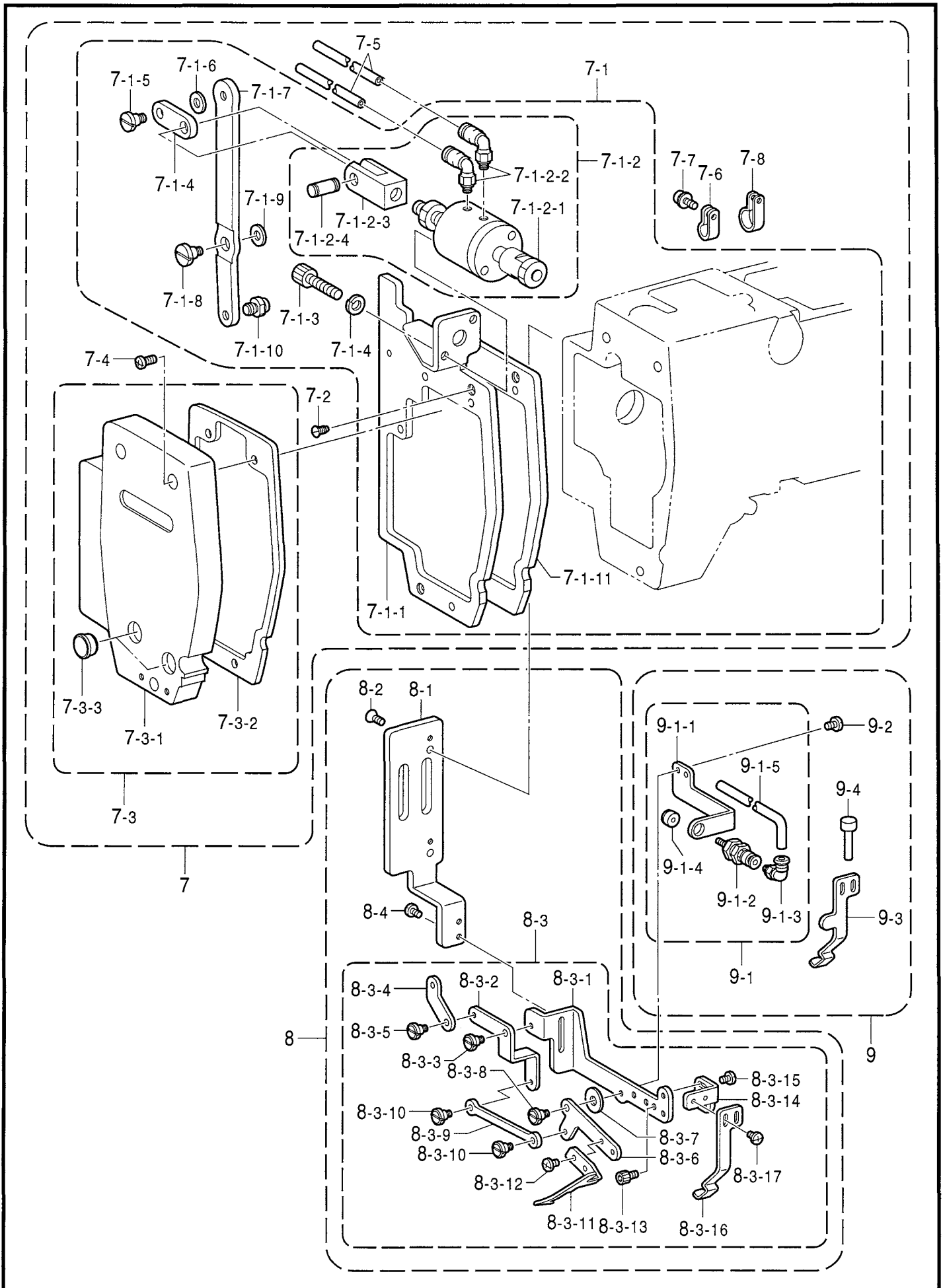

AA4.補助装置関係 (オプション部品) / Auxiliary device (Option parts)

REF.NO	CODE	QTY	品名	NAME OF PARTS	RM
			<2段押し足装置>	<2-step work clamp device>	
7	S51436001	1	2ダンオサエアシウチ311	2-STEP WORK CLAMP DEVICE, 311	
7-1	S51471101	1	2ダンオサエソウチクミ311	2-STEP WORK CLAMP ASSY, 311	
7-1-1	S51472001	1	メンイタスペーサ311	SPACER, 311	
7-1-2	S51473000	1	シリンダー25-10クミ	CYLINDER ASSY, 25-10	
7-1-2-1	S51474000	1	シリンダー25-10	CYLINDER, 25-10	
7-1-2-2	S11426000	2	エルボユニオン4M5	ELBOW UNION, 4M5	
7-1-2-3	S41523000	1	2ヤマナツクルジョイント	KNUKLE JOINT	
7-1-2-4	S41524000	1	ナツクルヨウピン	PIN	
7-1-3	018062036	2	アナホルト6X20	BOLT, SOCKET M6X20	
7-1-4	S51476001	1	リンク	LINK	
7-1-5	150451001	1	ダンネジ6.35	SHOULDER SCREW, SM6.35	
7-1-6	153138001	1	ザガネ	WASHER, PLAIN 6.5	
7-1-7	S51477001	1	シテントウレバー	LEVER	
7-1-8	S19817001	1	ダンネジ5.95	SHOULDER SCREW, SM5.95	
7-1-9	153138001	1	ザガネ	WASHER, PLAIN 6.5	
7-1-10	SA1462001	1	コロシク6.35	ROLLER SHAFT, W/SCREW SM6.35	
7-1-11	S51488000	1	311スペーサパッキング	PACKING, 311	
7-2	100032004	3	サラネジ4.37	SCREW, FLAT SM4.37-40X8	
7-3	S51480009	1	311メンイタ2SFクミ	FACE PLATE ASSY, 2-SF :311	
7-3-1	S51481009	1	311メンイタ2SF	FACE PLATE, 2-SF :311	
7-3-2	S51482000	1	311メンイタパッキング2SF	PACKING, 2-SF	
7-3-3	117934001	2	ゴムセン13.5	RUBBER CAP, 13.5	
7-4	062711412	3	ナベコ4.76-32X14	SCREW, PAN SM4.76-32X14	
7-5	S15031008	2	エアチューブ	AIR TUBE, 4X2.5 L=1900	
7-6	525664000	1	コードホルダ#6	CORD HOLDER, #6	
7-7	0A5400806	1	+ナベザクミ4X8DB	SCREW, PAN (S/P WASHER) M4X8	
7-8	525567000	3	コードホルダ#8	CORD HOLDER, #8	
			<糸つかみセット>	<U-thread nipper device>	
8	S53154001	1	イトツカミセット	U-THREAD NIPPER DEVICE	
8-1	S53071001	1	ソレノイドベースイタ	SOLENOID BASE PLATE	
8-2	100032004	2	サラネジ4.37	SCREW, FLAT SM4.37-40X8	
8-3	S53070001	1	イトツカミクミ300E	THREAD NIPPER ASSY, 300E	
8-3-1	S53072001	1	イトツカミシテントウ	THREAD NIPPER FULCRUM PLATE	
8-3-2	S53073001	1	イトツカミクランク	THREAD NIPPER CRANK	
8-3-3	S46842001	1	ダンネジ4	SHOULDER SCREW, M4	
8-3-4	S53074001	1	ソレノイドレンカン	SOLENOID CONNECTING ROD	
8-3-5	113730001	1	ダンネジ4.37	SHOULDER SCREW, SM4.37	
8-3-6	S53075001	1	イトツカミブラケット	THREAD NIPPER BRACKET	
8-3-7	S19543001	1	ザガネ	WASHER	
8-3-8	S46842001	1	ダンネジ4	SHOULDER SCREW, M4	
8-3-9	S53076001	1	イトツカミレンカン	THREAD NIPPER CONNECTING PLATE	
8-3-10	113730001	2	ダンネジ4.37	SHOULDER SCREW, SM4.37	
8-3-11	S53077001	1	イトツカミ	THREAD NIPPER	
8-3-12	060670512	2	バインド357-40X5	SCREW, BIND SM3.57-40X5	
8-3-13	S59892001	1	アナホルト437-40X5	BOLT, SOCKET SM4.37-40X5	
8-3-14	S53078001	1	イトオサエブラケット	THREAD PRESSER BRACKET	
8-3-15	060670512	2	バインド357-40X5	SCREW, BIND SM3.57-40X5	
8-3-16	S53079001	1	イトオサエ	THREAD PRESSER	
8-3-17	060670512	2	バインド357-40X5	SCREW, BIND SM3.57-40X5	
8-4	060680512	2	バインド437-40X5	SCREW, BIND SM4.37-40X5	

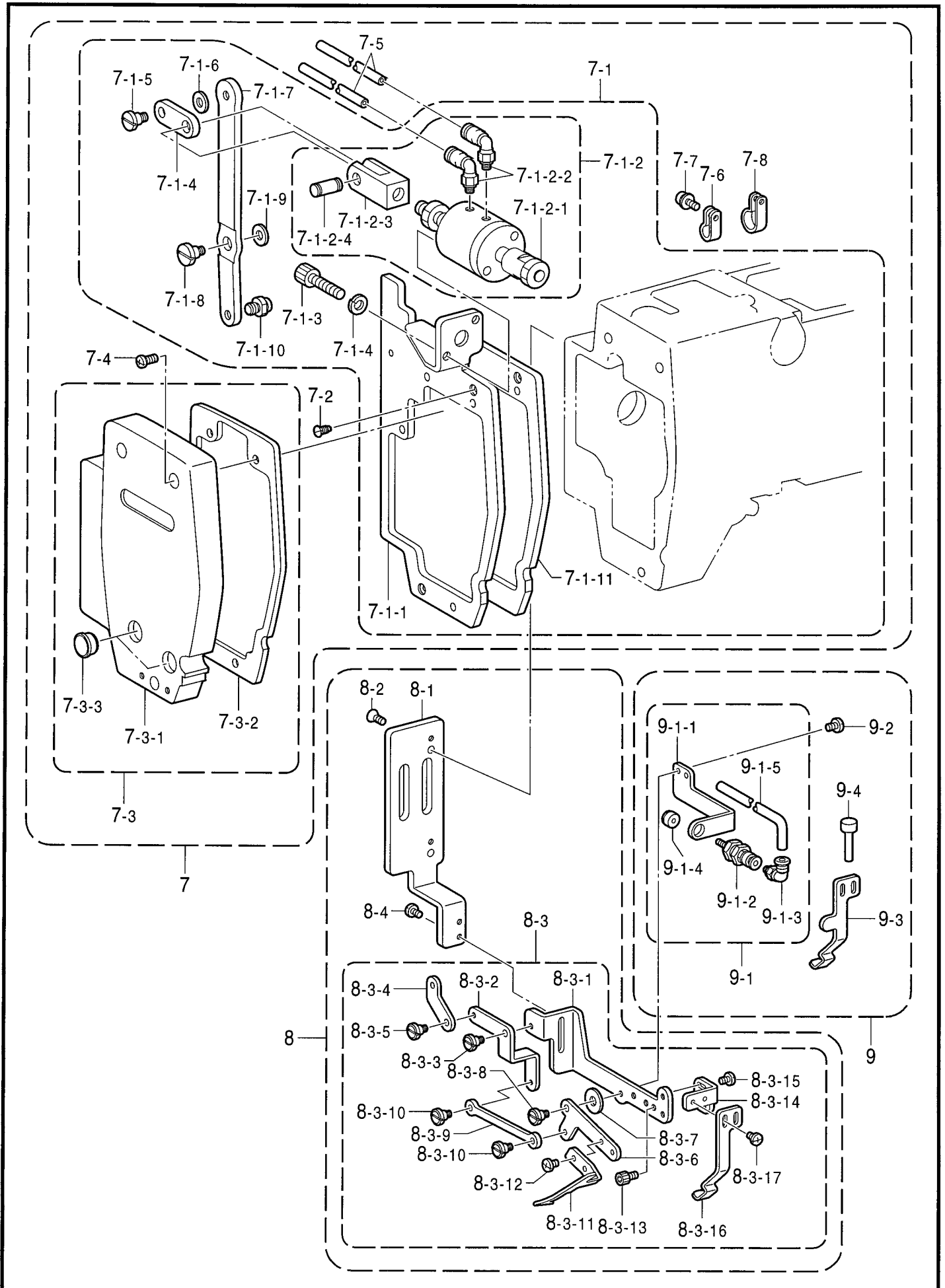

AA4.補助装置関係 (オプション部品) / Auxiliary device (Option parts)

REF.NO	CODE	QTY	品名	NAME OF PARTS	RM
			<糸放しシリンダーセット>	<Thread release cylinder set>	
9	S53155001	1	イトハナシリンダーセット	THREAD RELEASE CYLINDER SET	
9-1	S53080001	1	イトハナシリンダータミ	THREAD RELEASE CYLINDER ASSY	
9-1-1	S53081001	1	シリンダーブラケット	CYLINDER BRACKET	
9-1-2	S16996000	1	シリンダー6X5	CYLINDER, 6X5	
9-1-3	S18382000	1	エルボ M5	ELBOW, M5	
9-1-4	S16997100	1	ウワイトオサエ	NEEDLE THREAD PRESSER	
9-1-5	S15031008	1	エアチューブ	AIR TUBE, 4X2.5 L=1900	
9-2	060680512	2	バインド 437-40X5	SCREW, BIND SM4.37-40X5	
9-3	S53082001	1	イトオサエS	TR-PRESSER, S	
9-4	S04897000	1	プラグ 4	PLUG, 4	

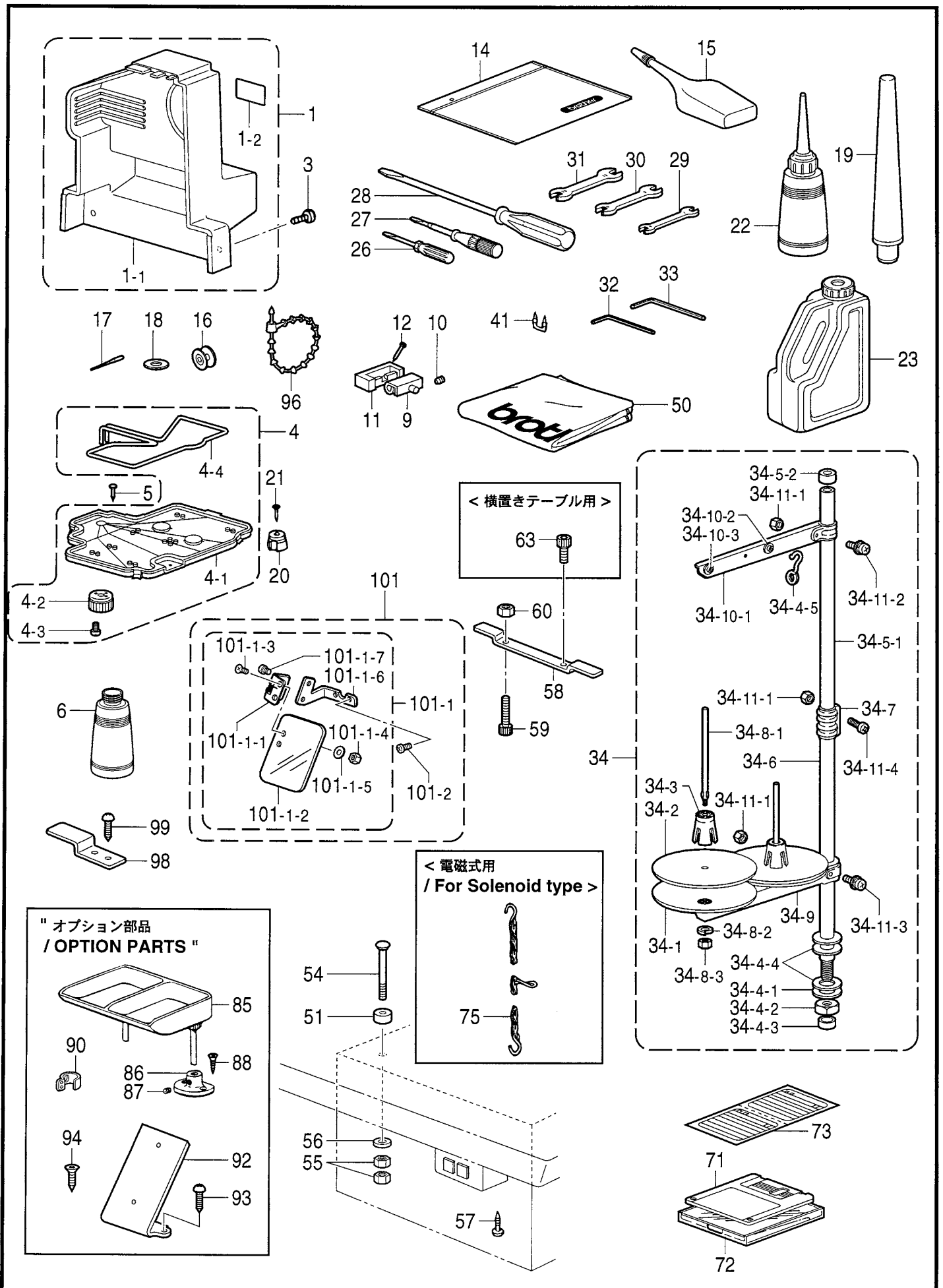

Z.付属品関係 / Accessories

REF.NO	CODE	Q'TY	品名	NAME OF PARTS	RM
			<国内用>	<For Japan only>	
1	S55925101	1	ベルトカバーギ	-----	
1-1	S55192000	1	ベルトカバー	-----	
1-2	S38357001	1	ソウサチユウイラベルBAS7	-----	
			<輸出用>	<For Export>	
1	S55925102	1	-----	BELT COVER ASSY	
1-1	S55192000	1	-----	BELT COVER	
1-2	S38571001	1	-----	LABEL, OPERATION (BAS) ENG.	
			<ベルトカバー用>	<For Belt cover>	
3	062401006	2	ナベコ4X10	SCREW, PAN M4X10	
4	S38039209	1	オイルパンギ	OIL PAN ASSY	
4-1	S38040209	1	オイルパン	OIL PAN	
4-2	154467001	1	ハイユキヤツブ	DUST OILER	
4-3	037301215	2	Vナベタツピン3X12	TAPPING SCREW, PAN V M3X12	
4-4	S18093100	1	クミモ4X4	WICK, 4X4 L=1100	
5	109714000	5	クギ	NAIL	
6	114486002	1	ホリオリタイ	OILER	
9	143882001	2	トウブヒンジ	HEAD HINGE	
10	014760632	2	アナクホミ595-28X6	SET SCREW, SOCKET SM5.95-28X6	
11	143910009	2	トウブヒンジウケゴム	RUBBER CUSHION	
12	109714000	4	クギ	NAIL	
14	122991001	1	フゾクヒンホリフクロ	ACCESSORY PE. BAG	
15	S06706001	1	シリコンオイル	SILICONE OIL	
			<311F-0, 311F-L, 326F-0 中厚物、厚物用>	<For Medium & heavy-weight materials 311F-0, 311F-L & 326F-0>	
16	S15665001	3	ボビンLA	BOBBIN, LA	
			<311F-0極厚物用>	<For Extra heavy-weight materials of 311F-0>	
16	S15666001	3	ボビンLB	BOBBIN, LB	
			<中厚物用>	<For Medium-weight materials>	
17	SA1752016	1	107415ハリ4コイリクミ (#16)	NEEDLE 4PIECE ASSY, 107415 (#16)	
			<311F-0, 326F-0 厚物用>	<For Heavy-weight materials	
17	SA1645019	1	145646ハリ4コイリクミ (#19)	NEEDLE 4PIECE ASSY, 145646 (#19)	
			<311F-L 厚物用>	<For Heavy-weight materials of 311F-L>	
17	SA1645019	1	145646ハリ4コイリクミ (#19)	NEEDLE 4PIECE ASSY, 145646 (#19)	
			<極厚物用>	<For Extra heavy-weight materials>	
17	SA1645025	1	145646ハリ4コイリクミ (#25)	NEEDLE 4PIECE ASSY, 1456 6 (#25)	
18	S10208001	1	イトウハカンサ (t=0.4)	MOVABLE KNIFE SPACER (t=0.4)	
18	S10208002	1	イトウハカンサ (t=0.5)	MOVABLE KNIFE SPACER (t=0.5)	
18	S10208003	1	イトウハカンサ (t=0.6)	MOVABLE KNIFE SPACER (t=0.6)	
19	S45724009	1	マクラA	HEAD REST, A	
20	S38043009	2	クッション	CUSHION	
21	109714000	2	クギ	NAIL	
22	114483002	1	ホリオリタイギ	OILER ASSY	

BAS-311F-0-910

◎付属品の明細は変更することがあります。

◎The details of included accessories are subject to change.

Z.付属品関係 / Accessories

REF.NO	CODE	Q'TY	品名	NAME OF PARTS	RM
23	S55663001	1	オイルタンクミ	OIL TANK ASSY	
26	142443001	1	ネジマワシ1.9X52	SCREW-DRIVER, 1.9X52	
27	118837001	1	ネジマワシ3.4X70	SCREW-DRIVER, 3.4X70	
28	101572101	1	ネジマワシ5.5X190	SCREW-DRIVER, 5.5X190	
29	107779001	1	スパナ6X7	WRENCH, 6X7	
30	100887001	1	スパナ8X9	WRENCH, 8X9	
31	107780001	1	スパナ10X12	WRENCH, 10X12	
32	142721001	1	6カクホウスパナ3	HEXAGONAL WRENCH, 3	
33	118064001	1	6カクホウスパナ4	HEXAGONAL WRENCH, 4	
34	S02763502	1	イトタテダイクミ2DR	COTTON STAND ASSY, 2DR	
34-1	S51283001	2	ウケザラ	SPOOL STAND BASE	
34-2	150182000	2	スプールマット	SPOOL MAT	
34-3	S51282001	2	スプールクッション	SPOOL CUSHION	
34-4-1	150206002	1	ヒラサガネ16	WASHER, PLAIN 16	
34-4-2	S38648001	1	6カクナツU5/8	NUT, U5/8-28	
34-4-3	150174000	1	コラムキャップ	COLUMN CAP	
34-4-4	S01005000	2	イトタテゴム	RUBBER WASHER	
34-4-5	S02747101	1	イトカケハネ	SPRING	
34-5-1	150172003	1	コラムパイプ	COLUMN PIPE W/CAP	
34-5-2	150174000	1	コラムキャップ	COLUMN CAP	
34-6	156112003	1	コラムパイプD	COLUMN PIPE, D	
34-7	150173003	1	コラムジョイント	COLUMN JOINT	
34-8-1	150179002	2	スプールシクバ	SPOOL SHAFT, B	
34-8-2	028050246	2	ハネサガネ2-5	WASHER, SPRING 2-5	
34-8-3	021500106	2	1シユナツ5	NUT, 1 M5	
34-9	S02778002	1	スプールホルダー-2	SPOOL HOLDER, 2	
34-10-1	S02787002	1	スレツトハンガー-2	THREAD HANGER, 2	
34-10-2	150183000	2	イトカケハンガーダイ	THREAD HANGER BASE	
34-10-3	142990001	2	スレツトブツシユ	THREAD BUSH	
34-11-1	021500106	4	1シユナツ5	NUT, 1 M5	
34-11-2	S37038001	1	ナヘコ5X14	SCREW, PAN M5X14	
34-11-3	S37038001	1	ナヘコM5X32	SCREW, PAN M5X32	
34-11-4	S37037001	2	ナヘコ5X14	SCREW, PAN M5X14	
41	200190001	7	ステツプル	STAPLE	
50	144226001	1	トウブカバー	HEAD COVER	
51	S33006001	4	<コントロールbox取付用> モータスペーサ	<Setting the control box> MOTOR SPACER	
54	133740006	4	カクネボルト6X70	BOLT, SQUARE M6X70	
55	021060106	8	1シユナツ6	NUT, 1 M6	
56	025060336	4	ヒラサガネダイ6	WASHER, PLAIN L 6	
57	032461606	2	<電源SW取付用> +マルモクネジ4.5X16	<Setting the power switch> WOOD SCREW, ROUND M4.5X16	

BAS-311F-0-910

©付属品の明細は変更することがあります。

©The details of included accessories are subject to change.

Z. 付属品関係 / Accessories

REF.NO	CODE	Q'TY	品名	NAME OF PARTS	RM
58	S42882001	1	ヒンジオサエ	HINGE PRESSER	
59	018405032	2	アナホルト4X50	BOLT, SOCKET M4X50	
60	021400102	2	ナット1シユ4	NUT, 1 M4	
63	018400632	2	アナホルト4X6	BOLT, SOCKET M4X6	
71	S43273000	1	3.5メディア2HD	3.5 MEDIA, 2HD	
72	S09989000	1	フロッピーケース	FLOPPY CASE	
73	S42658000	1	3.5インデックスラベル	INDEX LABEL, 3.5FD	
			<電磁式用>	<For Solenoid type>	
75	S10472001	1	クサリクミ	CHAIN ASSY	
			<標準部品>	<Standard parts>	
98	S55633001	1	スイッチオシタ	SWITCHING PLATE	
99	032422003	2	+マルモクネジ4.1X20	WOOD SCREW, ROUND M4.1X20	
101	S49602201	1	アイガードセットC	EYE GUARD SET, C	
101-1	S44493101	1	アイガードクミ	EYE GUARD ASSY	
101-1-1	S44483001	1	チョウバンクミ	HINGE ASSY	
101-1-2	S44485001	1	アイガード	EYE GUARD	
101-1-3	061660806	2	サコ318-40X8	SCREW, FLAT SM3.18-40X8	
101-1-4	021660102	2	ナット1シユ3.18	NUT, 1 SM3.18	
101-1-5	026030232	2	ヒラサガネミカキ 3	WASHER, PLAIN M 3	
101-1-6	S44486101	1	アイガードホルダーA	EYE GUARD HOLDER, A	
101-1-7	062670512	2	ナベコ357-40X5	SCREW, PAN SM3.57-40X5	
101-2	062671016	2	ナベコ357-40X10	SCREW, PAN SM3.57-40X10	
			"オプション部品"	"OPTION PARTS"	
85	S18641009	1	ボタンサラフクロイリ	BUTTON TRAY WITH BAG	
86	153843009	1	ボタンサラアシホルダ	BUTTON TRAY HOLDER	
87	014760632	1	アナクホミ595-28X6	SET SCREW, SOCKET SM5.95-28X6	
88	0B1351606	2	+サラモク35X16	WOOD SCREW, FLAT M3.5X16	
90	S41222101	1	ハリボウイトアンナイB	NEEDLE BAR THREAD GUIDE, B	
92	S42890001	1	プログラマササエ	PROGRAMMER SUPPORT	
93	032422003	2	+マルモクネジ4.1X20	WOOD SCREW, ROUND M4.1X20	
94	0B1351606	2	+サラモク35X16	WOOD SCREW, FLAT M3.5X16	
			<エア式用>	<For Pneumatic type>	
96	340400001	1	ユニタイバンド	BEAD BAND	

BAS-311F-0-910

©付属品の明細は変更することがあります。

©The details of included accessories are subject to change.

押え足 / Presser foot

Ref.No.A *	Ref.No.B	Ref.No.C	Ref.No.D
Ref.No.E	Ref.No.F	Ref.No.G	Ref.No.J
Ref.No.A-CUT	Ref.No.B-L	Ref.No.XA	

針穴板 / Needle hole plate

Ref.No.A	Ref.No.D	Ref.No.E	Ref.No.ED	Ref.No.F *
Ref.No.FD	Ref.No.H	Ref.No.L	Ref.No.M *	Ref.No.FM
Ref.No.3ザグリ	Ref.No.A-F			

Ga1.ゲージ部品一覧表 / Gauge parts list

REF.NO	CODE	Q'TY	品名	NAME OF PARTS	RM
A	S42843001	1	オサエアシA	PRESSER FOOT, A	※
			“オプション部品”	“OPTION PARTS”	
B	S42844001	1	オサエアシB	PRESSER FOOT, B	
C	S42845001	1	オサエアシC	PRESSER FOOT, C	
D	S42846001	1	オサエアシD	PRESSER FOOT, D	
E	S42847001	1	オサエアシE	PRESSER FOOT, E	
G	158592001	1	オサエアシG	PRESSER FOOT, G	
F	157237001	1	オサエアシF	WROK CLAMP, F	
J	S42848001	1	オサエアシJ	PRESSER FOOT, J	
A-CUT	S40214001	1	オサエアシA-CUT	PRESSER FOOT, A-CUT	
B-L	S49448001	1	オサエアシB-L	PRESSER FOOT, B-L	
			<横払いワイパー用>	<For Horizontal wiper>	
XA	S42849101	1	オサエアシXA	WORK CLAMP, XA	
			<中厚物、厚物用>	<For Medium & heavy-weight materials>	
F	S10213001	1	ハリアナイタF (φ 2.2)	NEEDLE HOLE PLATE, F (φ 2.2)	※
			<極厚物用>	<For Extra heavy-weight materials>	
M	S34348001	1	ハリアナイタM (φ 4.0)	NEEDLE HOLE PLATE, M (φ 4.0)	※
			“オプション部品”	“OPTION PARTS”	
A	S10211001	1	ハリアナイタA (φ 1.6)	NEEDLE HOLE PLATE, A (φ 1.6)	
D	S29997001	1	ハリアナイタD (φ 2.6)	NEEDLE HOLE PLATE, D (φ 2.6)	
E	S10212101	1	ハリアナイタE (φ 2.6)	NEEDLE HOLE PLATE, E (φ 2.6)	
ED	S30925001	1	ハリアナイタED (φ 3.4)	NEEDLE HOLE PLATE, ED (φ 3.4)	
FD	S30926001	1	ハリアナイタFD (φ 2.2)	NEEDLE HOLE PLATE, FD (φ 2.2)	
H	S30450001	1	ハリアナイタH (φ 2.6)	NEEDLE HOLE PLATE, H (φ 2.6)	
L	S25127001	1	ハリアナイタL (φ 3.3)	NEEDLE HOLE PLATE, L (φ 3.3)	
FM	S49980001	1	ハリアナイタFM (φ 2.2)	NEEDLE HOLE PLATE, FM (φ 2.2)	
3サグリ	S40217001	1	ハリアナイタ3サグリ (φ 3.3)	NEEDLE HOLE PLATE, 3 (φ 3.3)	
A-F	S51449001	1	ハリアナイタA-F (φ 1.6)	NEEDLE HOLE PLATE, A-F (φ 1.6)	

BAS-311F-0-Ga1

※印の部品は、標準部品です。

☆The ※ symbol is for Standard parts.

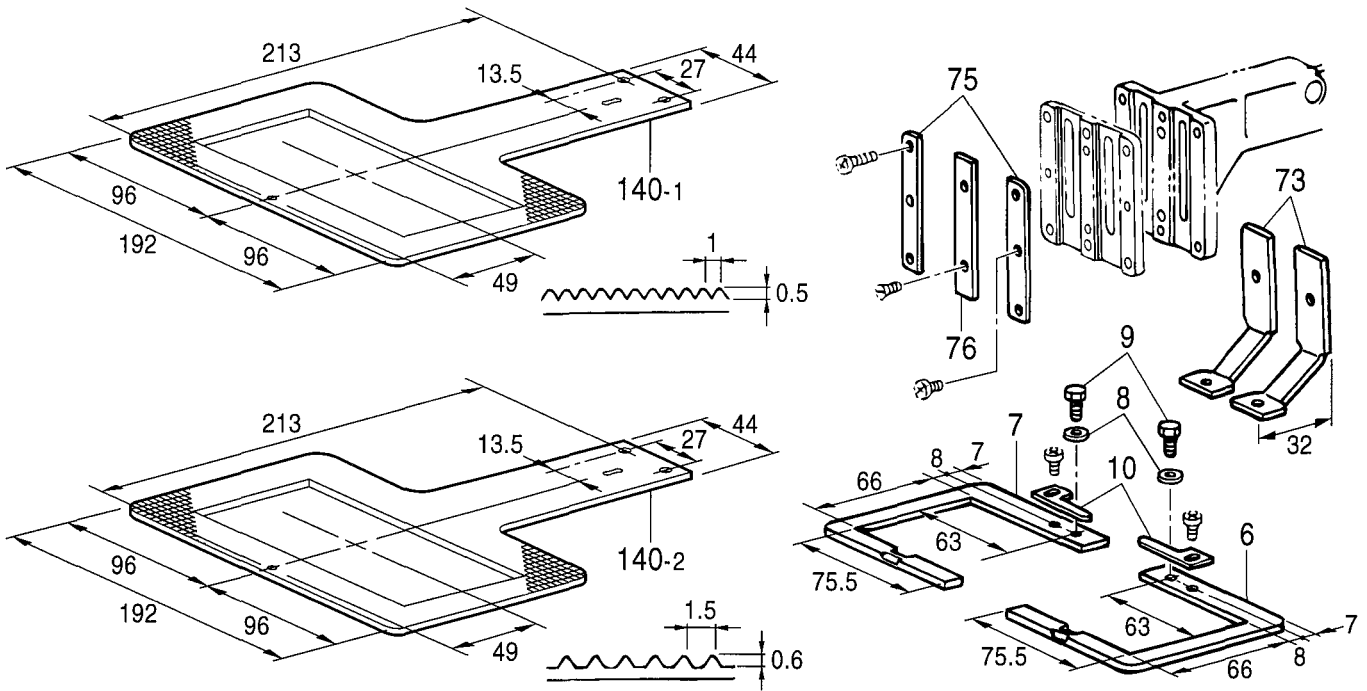

" オプション部品 / OPTION PARTS "

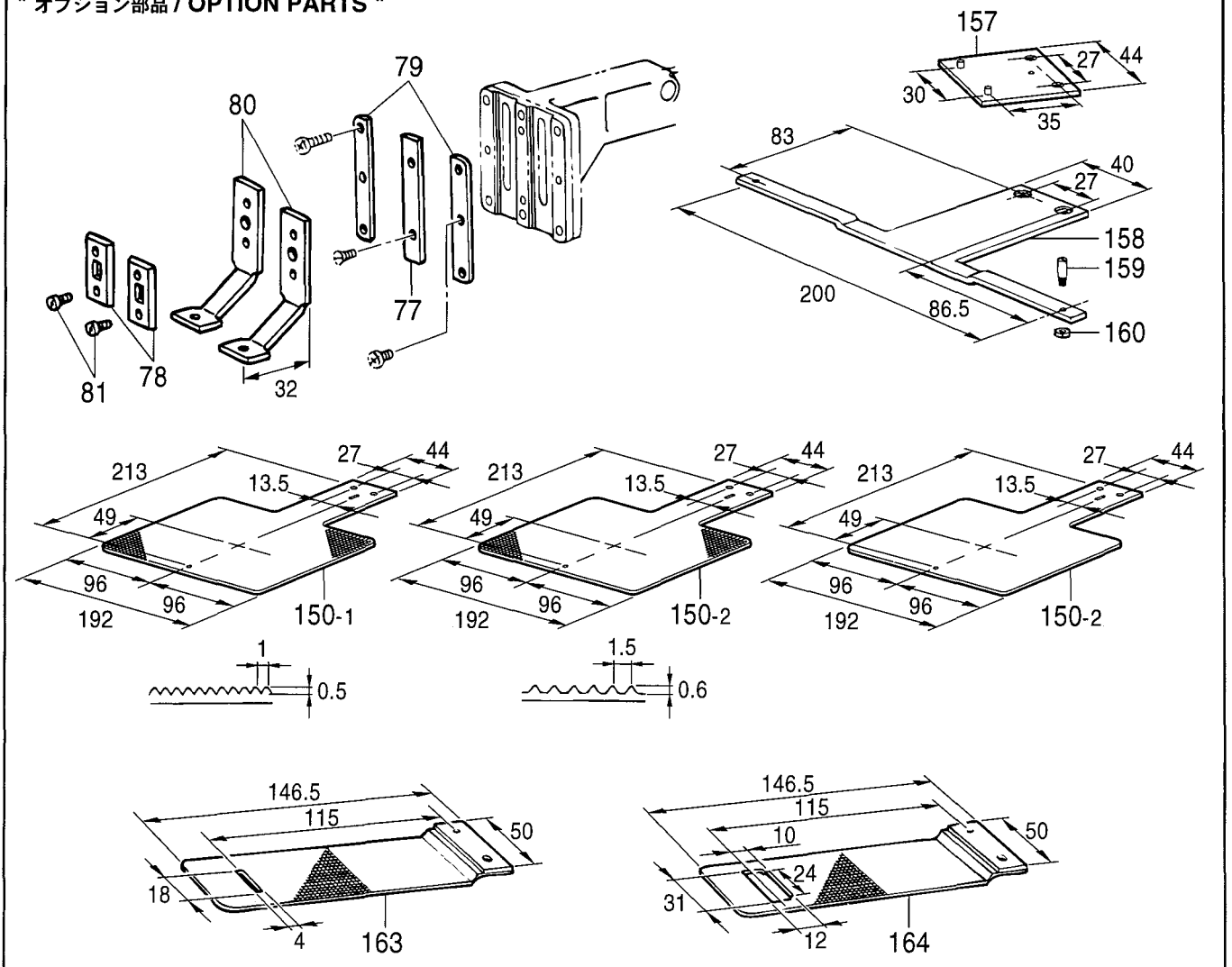

Ga2.ゲージ部品一覧表 (311F) / Gauge parts list (311F)

REF.NO	CODE	QTY	品名	NAME OF PARTS	RM
6	S42772001	1	311オサER	WORK CLAMP, R 311	※
7	S42773001	1	311オサEL	WORK CLAMP, L 311	※
8	025680232	2	ヒラサカネチユウ4.37	WASHER, PLAIN M 4.37	※
9	153403002	2	ホルト4.37X7	BOLT, SM4.37X7	※
10	S10065001	2	イチキメイタ	POSITIONING PLATE	※
73	S42801101	2	オサEアシNSE	WORK CLAMP, SE	※
75	S42787001	2	オサEアシオサエイタA	WORK CLAMP GUIDE BRACKET, A	※
76	S42884001	1	オサEアシオサエイタB	WORK CLAMP GUIDE PLATE, B	※
			<中厚物用>	<For Medium-weight materials>	
140-1	S55162001	1	オクリイタ311A (t=1.2)	FEED PLATE, 311 A (t=1.2)	※
			<厚物、極厚物用>	<For Heavy-weight materials & extra heavy-weight materials>	
140-2	S55163001	1	オクリイタ311B (t=1.2)	FEED PLATE, 311 B (t=1.2)	※
			“オプション部品”	“OPTION PARTS”	
77	S42798001	1	オサEアシオサエイタ	WORK CLAMP GUIDE BRACKET	
78	S42799001	2	オサEチヨウセツイタ	WORK CLAMP ADJUSTING PLATE	
79	S42800001	2	オサEスキマチヨウセツイタ	ADJUSTING PLATE	
80	S42802101	2	オサEアシSE-OP	WORK CLAMP, SE-OP	
81	062670512	4	ナベコ357-40X5	SCREW, PAN SM3.57-40X5	
			<送り板用アタッチメント>	<For Feed plate attachment>	
150-1	S55164001	1	オクリイタ311Aブランク	FEED PLATE BLANK, A 311	
150-2	S55165001	1	オクリイタ311Bブランク	FEED PLATE BLANK, B 311	
150-3	S55166001	1	オクリイタ311Cブランク	FEED PLATE BLANK, C 311	
			<ワンタッチ押え用>	<For One-touch work clamp>	
157	S57952001	1	OTオクリイタダイミ	OT-FEED PLATE BRACKET ASSY	
158	S13006101	1	カセットジグイタ	CASSETTE HOLDER PLATE	
159	S13007001	2	カセットジグピン	CASSETTE HOLDER PIN	
160	021660306	2	3シュナツト318-40	NUT, 3 SM3.18-40	
			<デニム用>	<For Denim>	
163	S14253001	1	OTオクリイタDE	OT-FEED PLATE BLANK, DE	
			<一般用>	<For General>	
164	S14252001	1	OTオクリイタST	OT-FEED PLATE	

BAS-311F-0-Ga2

☆※印の部品は、標準部品です。

☆The ※ symbol is for Standard parts.

Ga3 . ゲージ部品一覧表 (311Fオプション部品) / Gauge parts list (Option parts of 311F)

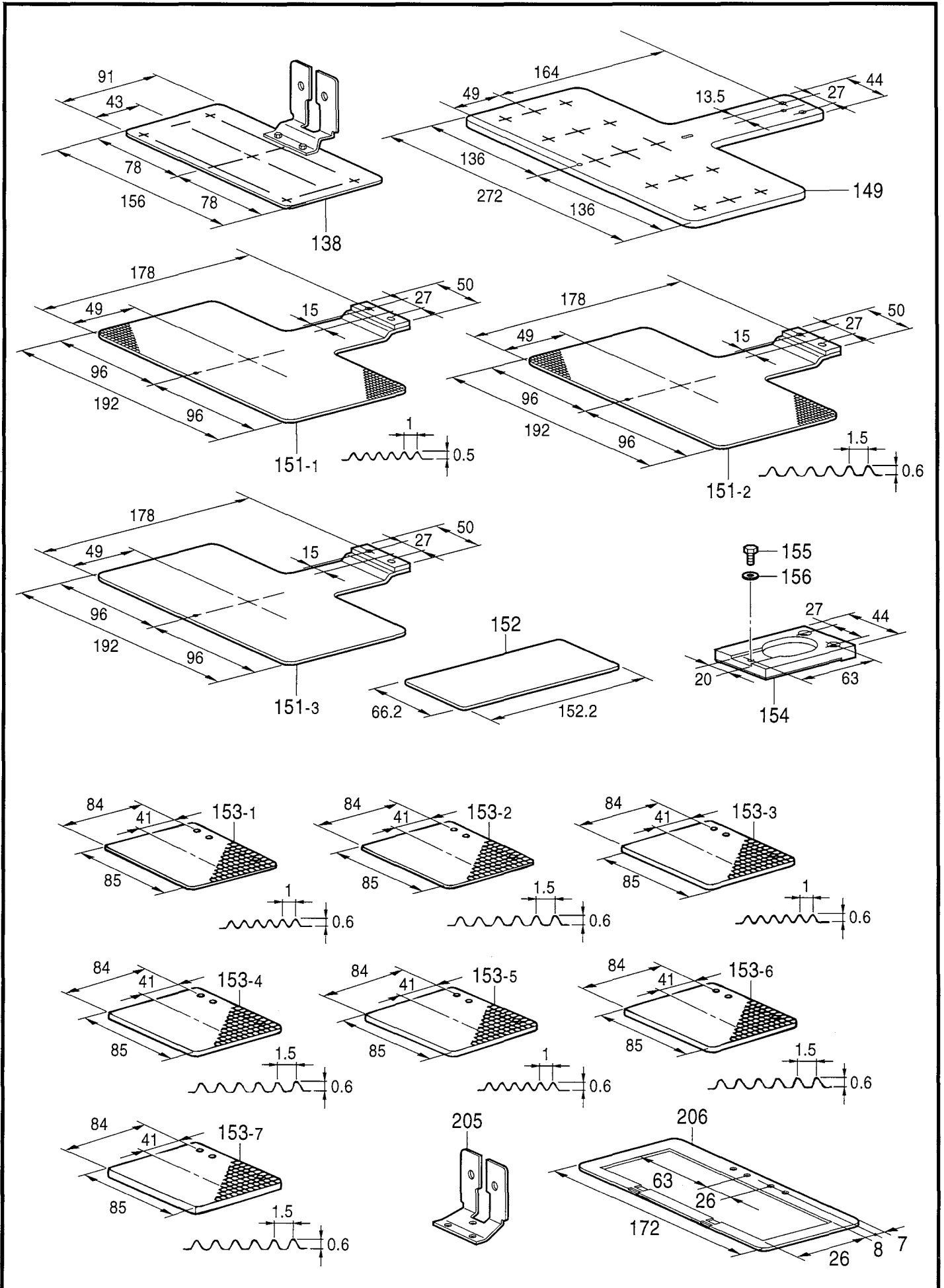

BAS-311F-0-Ga3

Ga3.ゲージ部品一覧表 (311F オプション部品) / Gauge parts list (Option parts of 311F)

REF.NO	CODE	Q'TY	品名	NAME OF PARTS	RM
138	S42888001	1	<ゲージ部品> ゲンテンキシユンイタミ	<Gauge parts> H-POSITION STANDARD PLATE ASSY	※
149	S55161001	1	ゲンテンキシユンイタ311	H-POSITION STANDARD PLATE, 311	
151-1	S43700001	1	<ワンタッチ押え用> OTオクリイタAブランク	<For One-touch work clamp> OT-FEED PLATE BLANK, A	
151-2	S43821001	1	OTオクリイタBブランク	OT-FEED PLATE BLANK, B	
151-3	S43822001	1	OTオクリイタCブランク	OT-FEED PLATE BLANK, C	
152	S43823000	1	<送り板用アタッチメント> オクリイタインナープレート	<For Feed plate attachment> INNER PLATE, FEED PLATE	
154	S51804001	1	オクリイタ外リツケダイ	FEED PLATE SETTING BASE	
155	153403002	1	ボルト4.37X7	BOLT, SM4.37X7	
156	025680232	1	ヒラサガネチユウ4.37	WASHER, PLAIN M 4.37	
153-1	S43824001	1	“押え用ブランク材” <板厚3.2mm> オサエブランクA-3.2	“The Blank for work clamp” <Thick = 3.2mm> WORK CLAMP BLANK, A-3.2	
153-2	S43825001	1	オサエブランクB-3.2	WORK CLAMP BLANK, B-3.2	
153-3	S43826001	1	<板厚4.0mm> オサエブランクA-4.0	<Thick = 4.0mm> WORK CLAMP BLANK, A-4.0	
153-4	S43827001	1	オサエブランクB-4.0	WORK CLAMP BLANK, B-4.0	
153-5	S43828001	1	<板厚5.0mm> オサエブランクA-5.0	<Thick = 5.0mm> WORK CLAMP BLANK, A-5.0	
153-6	S43829001	1	オサエブランクB-5.0	WORK CLAMP BLANK, B-5.0	
153-7	S43830001	1	<板厚6.0mm> オサエブランクC-6.0	<Thick = 6.0mm> WORK CLAMP BLANK, 6.0	
205	S43986201	1	オサエアシUN	WORK CLAMP, UN :SOL	
206	S43987001	1	311オサエUN	WORK CLAMP, 311 UN	

BAS-311F-0-Ga3

☆※印の部品は、標準部品です。

☆The ※ symbol is for Standard parts.

Ga4 . ゲージ部品一覧表 (311F-Lオプション部品) / Gauge parts list (Option parts of 311F-L)

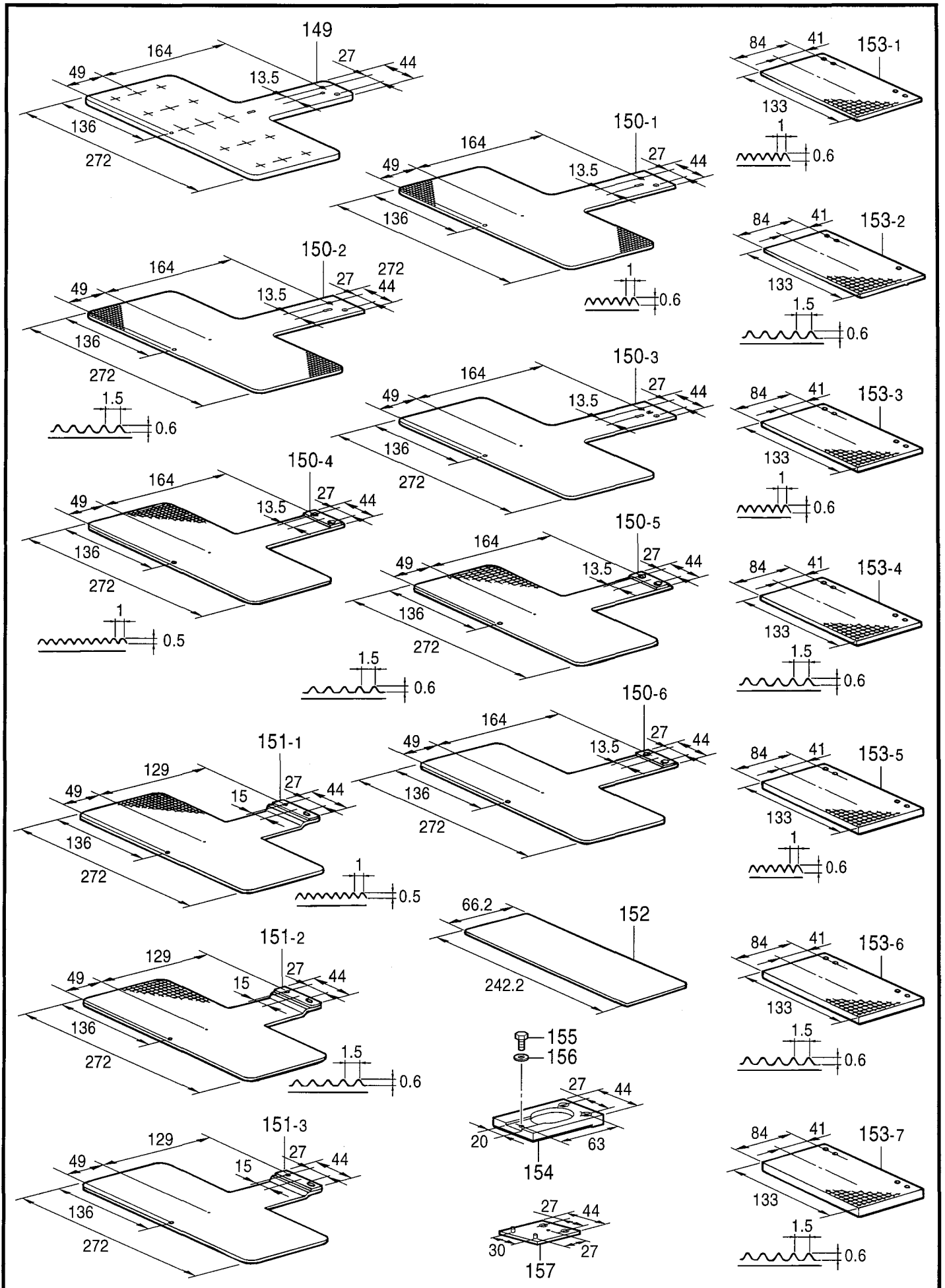

BAS-311F-L-Ga4

Ga4.ゲージ部品一覧表 (311F-L オプション部品) / Gauge parts list (Option parts of 311F-L)

REF.NO	CODE	QTY	品名	NAME OF PARTS	RM
149	S55161001	1	<ゲージ部品> ゲンテンキシユンイタ311	<Gauge parts> H-POSITION STANDARD PLATE, 311	
150-1	S57723001	1	<送り板用アタッチメント> オクリイタFLAフランク	<For Feed plate attachment> FEED PLATE FLA BLANK	
150-2	S57724001	1	オクリイタFLBフランク	FEED PLATE FLB BLANK	
150-3	S57725001	1	オクリイタFLCフランク	FEED PLATE FLC BLANK	
150-4	S57720001	1	<送り板用アタッチメント 皿タイプ> オクリイタFLAフランク	<For Feed plate attachment of flat type> FEED PLATE FLA BLANK	
150-5	S57721001	1	オクリイタFLBフランク	FEED PLATE FLB BLANKL	
150-6	S57722001	1	オクリイタFLCフランク	FEED PLATE FLC BLANK	
151-1	S57726001	1	<ワンタッチ押え用> OTオクリイタFLAフランク	<For One-touch work clamp> OT-FEED PLATE FLA BLANK	
151-2	S57727001	1	OTオクリイタFLBフランク	OT-FEED PLATE FLB BLANK	
151-3	S57728001	1	OTオクリイタFLCフランク	OT-FEED PLATE FLC BLANK	
152	S45603001	1	オクリイタインナープレート	FEED PLATE INNER PLATE	
153-1	S57729001	2	<押え用フランク材> オサエフランクFLA-3.2	<The Blank for work clamp> WORK CLAMP BLANK, A-3.2 311L	
153-2	S57730001	2	オサエフランクFLB-3.2	WORK CLAMP BLANK, A-3.2 311L	
153-3	S57731001	2	オサエフランクFLA-4.0	WORK CLAMP BLANK, A-4.0 311L	
153-4	S57732001	2	オサエフランクFLB-4.0	WORK CLAMP BLANK, B-4.0R 311L	
153-5	S57733001	2	オサエフランクFLA-5.0	WORK CLAMP BLANK, A-5.0L 311FL	
153-6	S57734001	2	オサエフランクFLB-5.0	WORK CLAMP BLANK, B-5.0L 311FL	
153-7	S57735001	2	オサエフランクFLB-6.0	WORK CLAMP BLANK, 6.0 311FL	
154	S51804001	1	<押え、押え板用アタッチメント> オクリイタトリツケダイ	<Attachment for work clamp & feed plate> FEED PLATE SETTING BASE	
155	153403002	1	ボルト4.37X7	BOLT, SM4.37X7	
156	025680232	1	ヒラサガネネチウ4.37	WASHER, PLAIN M 4.37	
157	S57952001	1	<ワンタッチ押え用> OTオクリイタダイミ	<For One-touch work clamp> OT-FEED PLATE BRACKET ASSY	

BAS-311F-L-Ga4

Ga5 . ゲージ部品一覧表 (326F-0オプション部品) / Gauge parts list (Option parts of 326F-0)

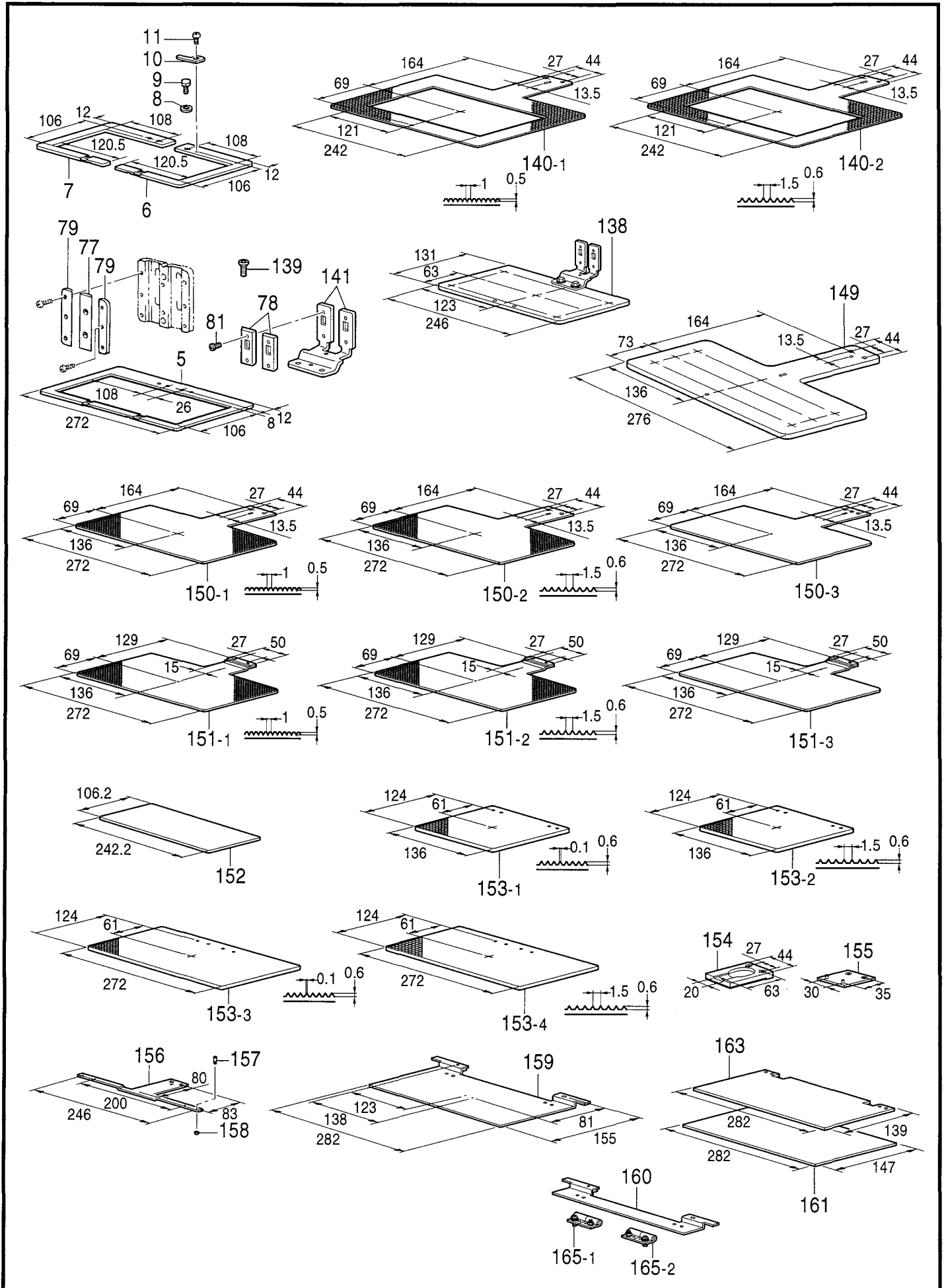

BAS-326F-0-Ga5

Ga5.ゲージ部品一覧表 (326F-0 オプション部品) / Gauge parts list (Option parts of 326F-0)

REF.NO	CODE	Q'TY	品名	NAME OF PARTS	RM
6	S51030001	1	326LオサIR	WORK CLAMP, R 326L	
7	S51031001	1	326LオサIL	WORK CLAMP, L 326L	
8	025680232	2	ヒラサガネチユウ4.37	WASHER, PLAIN M 4.37	
9	153403002	2	ボルト4.37X7	BOLT, SM4.37X7	
10	S10065001	2	イチキメイタ	POSITIONING PLATE	
11	062680512	2	ナベコ437-40X5	SCREW, PAN SM4.37-40X5	
			<中厚物用>	<For Medium-weight materials>	
140-1	S55952001	1	オクリイタ326A	FEED PLATE, 326A	
			<厚物用>	<For Heavy-weight materials>	
140-2	S55953001	1	オクリイタ326B	FEED PLATE, 326B	
5	S51042001	1	326LオサEUN	WORK CLAMP, UN 326L	
77	S42798001	1	オサエアシオサエイタ	WORK CLAMP GUIDE BRACKET	
78	S56536001	2	オサエチヨウセツイタ	ADJUSTING PLATE	
79	S42800001	2	オサエスキマチヨウセツイタ	ADJUSTING PLATE	
81	062670612	4	ナベコ357-40X6	SCREW, PAN SM3.57-40X6	
139	S49955101	2	オクリイタシメネジ	SCREW, W/SOCKET SM4.37	
141	S56537001	1	オサエアシUN	WORK CLAMP, UN	
			<ゲージ部品>	<Gauge parts>	
138	S56538001	1	ケンテンキジユンイタミ	H-POSITION STAND PLATE ASSY	※
149	S55954001	1	ケンテンキジユンイタ326	H-POSITION STANDARD PLATE, 326	
			<送り板用アタッチメント>	< Attachment for feed plate >	
150-1	S57844001	1	オクリイタ326Aブランク (t=1.2)	FEED PLATE BLANK, 326A (t=1.2)	
150-2	S57845001	1	オクリイタ326Bブランク (t=1.2)	FEED PLATE BLANK, 326B (t=1.2)	
150-3	S57846001	1	オクリイタ326Cブランク (t=1.2)	FEED PLATE BLANK, 326C (t=1.2)	
			<OT 送り板用アタッチメント>	< Attachment for one-touch feed plate >	
151-1	S51048101	1	OTオクリイタLAブランク (t=1.2)	OT-FEED PLATE BLANK, A :326L (t=1.2)	
151-2	S51049101	1	OTオクリイタLBブランク (t=1.2)	OT-FEED PLATE BLANK, B :326L (t=1.2)	
151-3	S51050101	1	OTオクリイタLCブランク (t=1.2)	OT-FEED PLATE BLANK, C :326L (t=1.2)	
152	S48555000	1	オクリイタインナープレート	FEED PLATE INNER PLATE	
			<押え用ブランク材>	<For work clamp blank>	
153-1	S51051001	1	オサエブランクLA3.2SE (t=3.2)	WORK CLAMP BLANK, SE A-3.2-L (t=3.2)	
153-1	S51053001	1	オサエブランクLA4.0SE (t=4.0)	WORK CLAMP BLANK, SE A-4.0-L (t=4.0)	
153-1	S51055001	1	オサエブランクLA5.0SE (t=5.0)	WORK CLAMP BLANK, SE A-5.0-L (t=5.0)	
153-1	S51057001	1	オサエブランクLA6.0SE (t=6.0)	WORK CLAMP BLANK, SE A-6.0-L (t=6.0)	
153-2	S51052001	1	オサエブランクLB3.2SE (t=3.2)	WORK CLAMP BLANK, SE B-3.2-L (t=3.2)	
153-2	S51054001	1	オサエブランクLB4.0SE (t=4.0)	WORK CLAMP BLANK, SE B-4.0-L (t=4.0)	
153-2	S51056001	1	オサエブランクLB5.0SE (t=5.0)	WORK CLAMP BLANK, SE B-5.0-L (t=5.0)	
153-2	S51058001	1	オサエブランクLB6.0SE (t=6.0)	WORK CLAMP BLANK, SE B-6.0-L (t=6.0)	
153-3	S51059001	1	オサエブランクLA3.2UN (t=3.2)	WORK CLAMP BLANK, UN A-3.2-L (t=3.2)	
153-3	S51061001	1	オサエブランクLA4.0UN (t=4.0)	WORK CLAMP BLANK, UN A-4.0-L (t=4.0)	
153-3	S51063001	1	オサエブランクLA5.0UN (t=5.0)	WORK CLAMP BLANK, UN A-5.0-L (t=5.0)	
153-3	S51065001	1	オサエブランクLA6.0UN (t=6.0)	WORK CLAMP BLANK, UN A-6.0-L (t=6.0)	
153-4	S51060001	1	オサエブランクLB3.2UN (t=3.2)	WORK CLAMP BLANK, UN B-3.2-L (t=3.2)	
153-4	S51062001	1	オサエブランクLB4.0UN (t=4.0)	WORK CLAMP BLANK, UN B-4.0-L (t=4.0)	
153-4	S51064001	1	オサエブランクLB5.0UN (t=5.0)	WORK CLAMP BLANK, UN B-5.0-L (t=5.0)	
153-4	S51066001	1	オサエブランクLB6.0UN (t=6.0)	WORK CLAMP BLANK, UN B-6.0-L (t=6.0)	

BAS-326F-0-Ga5

Ga5 . ゲージ部品一覧表 (326F-0オプション部品) / Gauge parts list (Option parts of 326F-0)

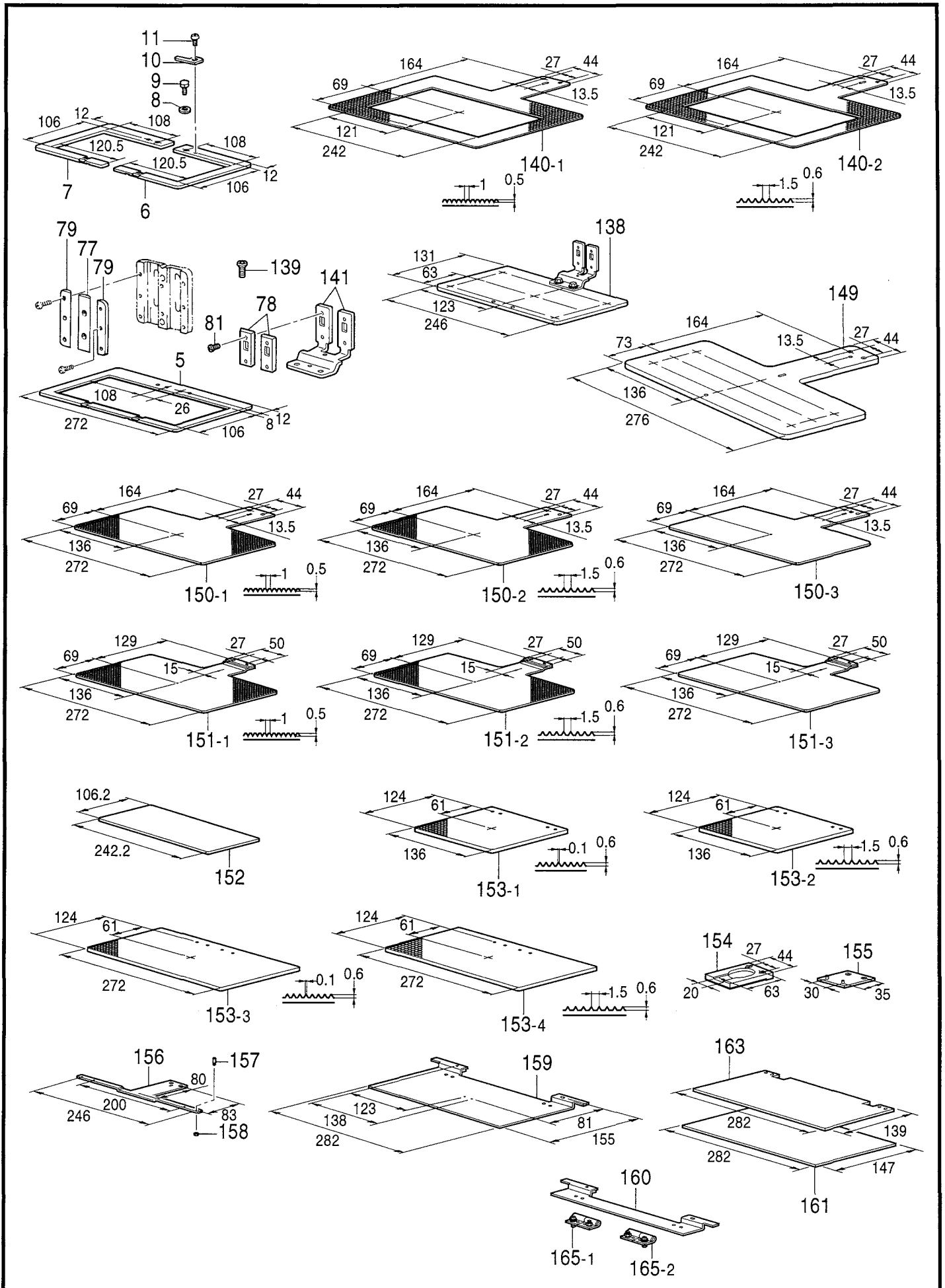

BAS-326F-0-Ga5

Ga5.ゲージ部品一覧表 (326F-0 オプション部品) / Gauge parts list (Option parts of 326F-0)

REF.NO	CODE	QTY	品名	NAME OF PARTS	RM
154	S51804001	1	<送り板用取付台> オクリ外リツケダイ	< Attachment for feed plate > FEED PLATE SETTING BASE	
155	S57952001	1	<OT 送り板用取付台> OTオクリダイ	< Attachment for one-touch feed plate > OT-FEED PLATE BRACKET ASSY	
156	S57849101	1	カセットシジイタ	CASSETTE HOLDER PLATE	
157	S13007001	2	カセットシジピン	CASSETTE HOLDER PIN	
158	021660306	2	3シユナツ318-40	NUT, 3 SM3.18-40	
159	S14392201	1	カセットイタD-A180	CASSETTE PLATE, D-A180	
160	S14388101	1	カセットイタD-B180	CASSETTE PLATE, D-B180	
161	S14386000	1	カセットシタイタA180 (t=1.0)	CASSETTE LOWER PLATE, A-180 (t=1.0)	
161	S14387000	1	カセットシタイタB180 (t=2.0)	CASSETTE LOWER PLATE, B-180 (t=2.0)	
163	S14389000	1	カセットイタU-A180 (t=1.0)	CASSETTE PLATE, U-A180 (t=1.0)	
163	S14390000	1	カセットイタU-B180 (t=2.0)	CASSETTE PLATE, U-B180 (t=2.0)	
165-1	152632001	1	チヨウハンクミキ	HINGE ASSY, R	
165-2	152633001	1	チヨウハンクミヒタリ	HINGE ASSY, L	

BAS-326F-0-Ga5

< 中押え反転装置用 / For Inner clamping device >

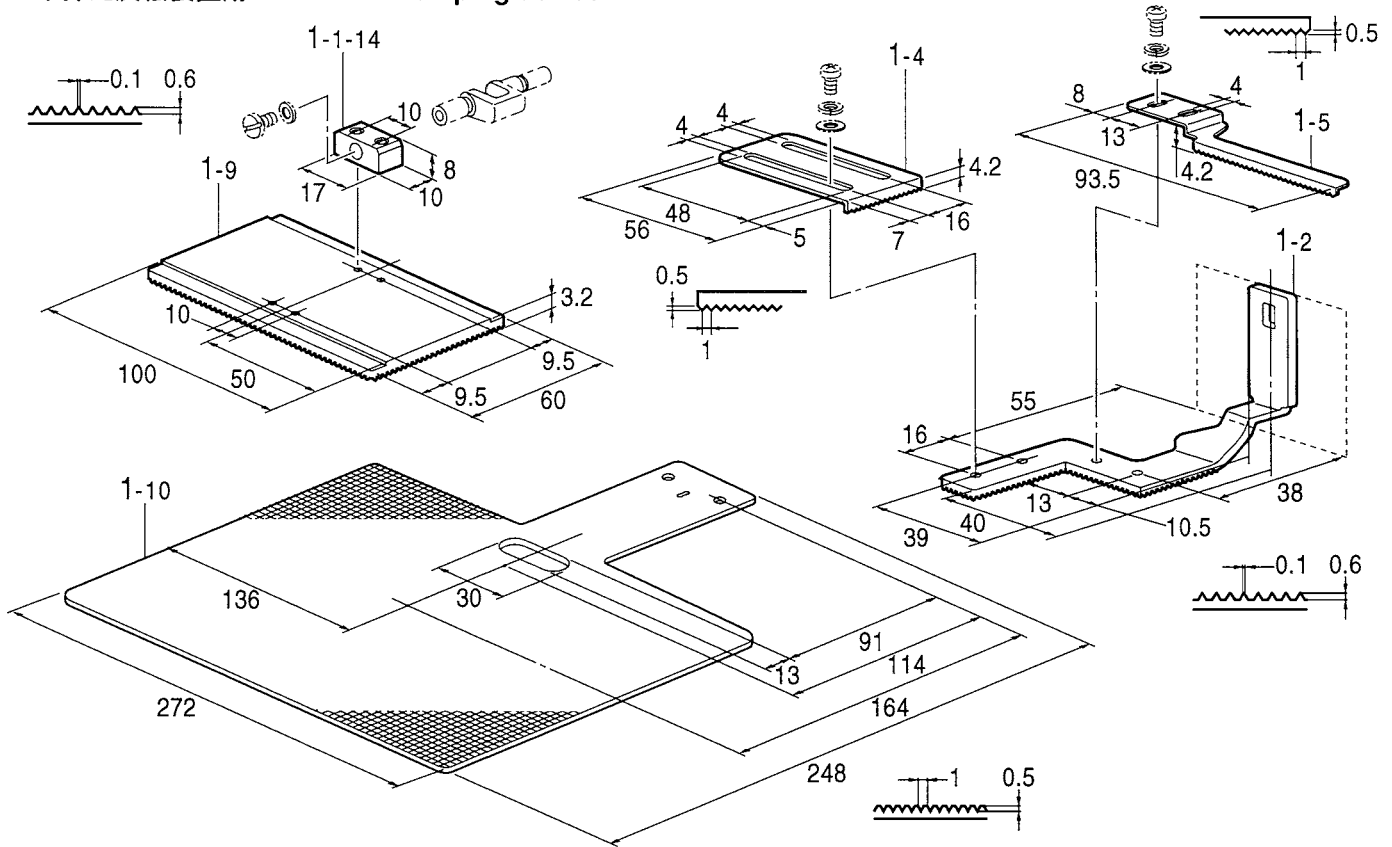

< 補給用部品 / For supply parts >

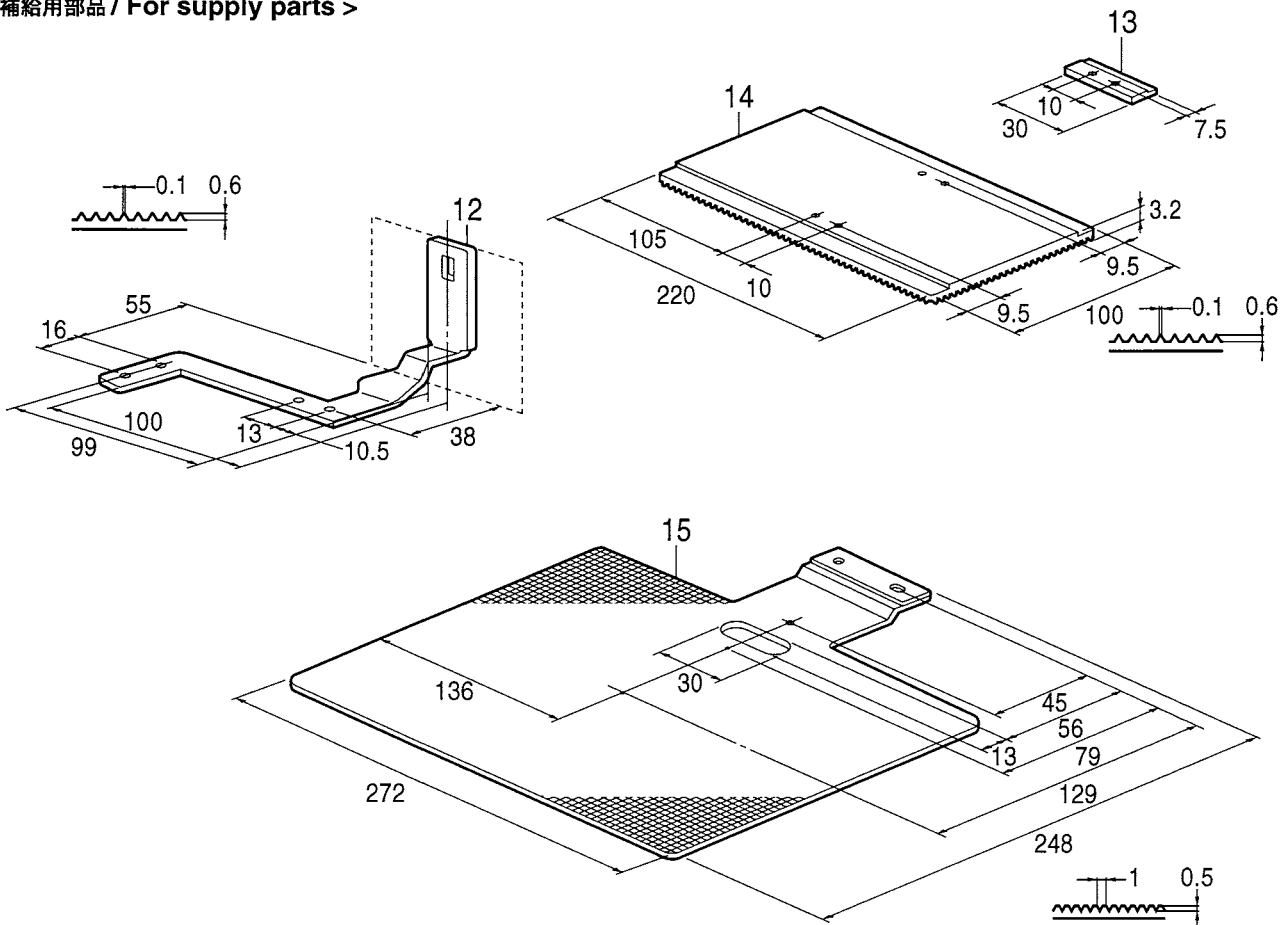

Ga6.ゲージ部品一覧表 (326F-0 オプション部品) / Gauge parts list (Option parts of 326F-0)







REF.NO	CODE	Q'TY	品名	NAME OF PARTS	RM
			<中押え反転装置用>	<For Inner clamping device>	
1-1-14	154237001	1	オサエイタホルダL	WORK CLAMP PLATE HOLDER, L	※
1-2	S57856001	1	ソトオサエアシ326F-1	OUTER WORK CLAMP, 326F-1	※
1-4	S57859001	1	イチキメイトL	POSITIONING PLATE, L	※
1-5	S57860001	1	イチキメイトR	POSITIONING PLATE, R	
1-8	028350242	4	ハネサガネ2-3.5	WASHER, SPRING 2-3.5	
1-9	154256101	1	オサエイタフランクA	WORK CLAMP PLATE BLANK, A	※
1-10	S57858001	1	オクリイタフランクH	FEED PLATE BLANK, H	※
			<補給用部品>	<For Supply parts>	
13	S10542001	1	ナカオサエLL	INNER CLAMP, LL	
14	S51077001	1	オサエイタフランクA326L	WORK CLAMP BLANK, A 326L	
15	S51078101	1	OTオクリイタフランクLH	OT-FEED PLATE BLANK, H :326L	
16	S57857001	1	ソトオサエアシ326F-3	OUTER WORK CLAMP, 326F-3	

BAS-326F-0-Ga6

☆※印の部品は、標準部品です。

☆The ※ symbol is for Standard parts.

Wa. 警告ラベル / Warning labels

警告ラベル / Warning labels	品名 / Name of parts	Size(mm)	Code
	電撃ラベル・和	40 X 64	S38353-101
	Label, elec. shock 4 lang.	35 X 118	S38352-101
	操作注意ラベル・(BAS) 和	40 X 64	S38357-001
		52 X 84	S38357-002
	Label, operation (BAS) Eng.	40 X 64	S38571-001
		52 X 84	S38571-002
	ラベル高温 13 X 20 Label, high temp.	13 X 20	J03663-001
	PE マーク Label, PE	7.5 X 12.5	S37059-001
	アースマーク Label, grounding	φ 12	S37060-001

CODE	REF.NO	Page	CODE	REF.NO	Page	CODE	REF.NO	Page	CODE	REF.NO	Page
002300403	U1 -1-1-11	90	014770632	C10-100	38	018401436	C10-95	38	022120306	W -1-2-2-7	94
002300403	U1 -1-2-15	90	014770632	C10-104	38	018401436	C14-95	46	025030135	AA1-1-1-9	104
002300403	U2 -1-3-11	92	014770632	C10-107	38	018401632	C12-1-10	42	025030232	P -1-1-8	78
002300603	T -1-15	88	014770632	C14-100	46	018401636	M2 -9	72	025030232	P -1-2-8	78
002301203	Q -10	82	014770632	C14-104	46	018405032	Z -59	116	025030232	Y1 -1-11-5	100
004063014	M1 -1-2	72	014770632	C14-107	46	018500836	D1 -26	50	025030232	Y2 -1-11-5	102
004400603	U1 -1-1-3	90	014770632	J -2	64	018501032	C2 -24	22	025030232	AA1-2-1-3	104
004400603	U1 -1-2-7	90	014770632	J -23	64	018501032	C9 -24	36	025030236	U1 -1-1-13	90
004400603	U2 -1-3-3	92	014780632	B1 -5	12	018501036	A3 -126	10	025030236	U1 -1-2-17	90
008400604	N -1-21	74	014780632	B1 -17	14	018501036	D1 -16	50	025030236	U2 -1-3-13	92
011679312	C1 -1-1-23	18	017062012	B2 -120	16	018501232	A2 -107	4	025040132	C12-1-21	42
011679312	C1 -1-2-20	18	017081606	P -32	80	018501232	A3 -107	8	025040232	C1 -1-1-18	18
011679312	C8 -1-20	34	017081606	W -1-2-1-3	94	018501232	C1 -1-2-22	18	025040232	C1 -1-2-10	18
011679312	C12-1-3	42	017081606	W -1-2-2-3	94	018501232	C8 -1-22	34	025040232	C3 -129	24
014400532	C3 -113	24	017081606	W -1-2-4	94	018501232	C13-24	44	025040232	C8 -1-10	34
014680432	C1 -1-1-14-1	18	017081606	W -1-2-9	94	018501232	E -20	54	025040232	C10-129	38
014680432	C1 -1-2-6-1	18	017082203	P -19	80	018501432	C3 -90	24	025040232	C13-40	44
014680432	C8 -1-6-1	34	017082206	W -9	96	018501432	C10-145	38	025040232	C13-43	44
014680432	C12-1-18-2	42	017501216	Y1 -1-1-23	100	018501432	C14-145	46	025040232	C14-129	46
014680632	E -3	54	017501216	Y2 -1-1-23	102	018501432	L -34	70	025040236	N -51	76
014680632	H -1-9	62	017680512	B2 -128	16	018501632	A2 -106	4	025050232	C2 -25	22
014680632	L -36	70	017711412	A1 -16	2	018501632	A3 -106	8	025050232	C3 -117	24
014680632	J -8-2	64	017711412	A2 -16	4	018501632	C2 -31	22	025050232	C9 -25	36
014710532	C10-113	38	017711412	A3 -16	8	018501632	C3 -118	24	025050232	C10-117	38
014710532	C14-113	46	017751412	D2 -50	52	018501632	C9 -31	36	025050232	C10-144	38
014760632	C1 -1-1-17	18	017761412	C12-14	42	018501632	C10-118	38	025050232	C13-25	44
014760632	C1 -1-2-9	18	017821813	AA2-2-3	106	018501632	C10-119	38	025050232	C14-117	46
014760632	C2 -28	22	017822212	L -37	70	018501632	C10-143	38	025050232	C14-144	46
014760632	C2 -38	22	018060832	L -8	70	018501632	C14-118	46	025050236	A3 -127	10
014760632	C2 -40	22	018061232	B2 -119	16	018501632	C14-119	46	025050236	C2 -60	22
014760632	C2 -56	22	018061632	C13-29	44	018501632	C14-143	46	025050236	C9 -60	36
014760632	C8 -1-9	34	018062036	AA4-7-1-3	110	018502532	C3 -119	24	025050236	T -6	88
014760632	C9 -28	36	018081636	T -7	88	018503032	C2 -63	22	025050236	W -1-5	94
014760632	C9 -38	36	018082032	A2 -102	4	018503032	C9 -63	36	025050336	T -10	88
014760632	C9 -40	36	018082032	A2 -104	4	021060102	B2 -121	16	025060132	C2 -15	22
014760632	C9 -56	36	018082032	A3 -102	8	021060106	M1 -1-3	72	025060132	C9 -15	36
014760632	C12-1-19	42	018082032	A3 -104	8	021060106	Z -55	115	025060132	C12-15	42
014760632	C12-1-24	42	018084032	B2 -112	16	021060206	Q -23	82	025060236	U1 -1-2-4	90
014760632	C13-27	44	018087032	B2 -115	16	021080106	P -23	80	025060336	Z -56	115
014760632	C13-31	44	018300836	Y1 -1-1-21	100	021400102	Z -60	116	025080132	A1 -44	2
014760632	C13-35	44	018300836	Y1 -1-1-22	100	021400106	N -52	76	025080132	A2 -44	4
014760632	D1 -19	50	018300836	Y2 -1-1-21	102	021400106	Q -32-10	84	025080132	A3 -44	8
014760632	E -7	54	018300836	Y2 -1-1-22	102	021400206	N -1-31	74	025080232	B2 -114	16
014760632	E -10	54	018301036	Y1 -1-1-8	100	021500106	P -5	78	025080232	B2 -117	16
014760632	E -15	54	018301036	Y2 -1-1-8	102	021500106	T -9	88	025080232	P -21	80
014760632	J -33	64	018301236	Y1 -1-1-7	100	021500106	Z -34-8-3	115	025080236	W -1-2-6	94
014760632	Z -10	114	018301236	Y2 -1-1-7	102	021500106	Z -34-11-1	115	025080236	W -12	96
014760632	Z -87	116	018302032	AA2-2-1-2	106	021500216	Y1 -1-1-24	100	025080336	P -22	80
014760632	G -28	60	018400632	A1 -117	2	021500216	Y2 -1-1-24	102	025350132	Y1 -1-1-15	100
014760632	K -33	68	018400632	A2 -117	4	021660102	K -38	68	025350132	Y2 -1-1-15	102
014770632	E -13-1	54	018400632	A3 -117	8	021660102	Z -101-1-4	116	025350332	A1 -33	2
014770632	B1 -12-1-2	12	018400632	C1 -1-1-19	18	021660306	C6 -160	30	025350332	A2 -33	4
014770632	B1 -12-2-2	12	018400632	C1 -1-2-11	18	021660306	C15-158	48	025350332	A3 -33	8
014770632	B1 -12-3-2	12	018400632	C8 -1-11	34	021660306	Ga2-160	120	025350332	M1 -16	72
014770632	C2 -43	22	018400632	Z -63	116	021660306	Ga5-158	128	025350332	Y1 -1-7	100
014770632	C2 -51	22	018400832	C13-42	44	021670102	F -29	58	025350332	Y2 -1-7	102
014770632	C3 -100	24	018400832	Q -5	82	021670102	M1 -10	72	025680132	V -7	92
014770632	C3 -104	24	018400832	C12-1-20	42	021670202	K -36	68	025680232	C1 -8	20
014770632	C3 -107	24	018401032	C13-39	44	021680202	H -1-24	62	025680232	C3 -137	24
014770632	C9 -43	36	018401236	B2 -10-4	16	021750102	D2 -48	52	025680232	C5 -156	28
014770632	C9 -51	36	018401436	C3 -95	24	022120306	W -1-2-1-7	94	025680232	C8 -8	34

索引 / INDEX

CODE	REF.NO	Page	CODE	REF.NO	Page	CODE	REF.NO	Page	CODE	REF.NO	Page
025680232	C10-137	38	037200615	S -1-10	86	060670512	AA4-8-3-12	110	062670512	Y1 -1-6	100
025680232	C11-156	40	037300615	S -1-13	86	060670512	AA4-8-3-15	110	062670512	Y2 -1-6	102
025680232	C12-8	42	037300816	T -1-13	88	060670512	AA4-8-3-17	110	062670512	Z -101-1-7	116
025680232	C14-137	46	037301015	S -1-6	86	060670612	A1 -38	2	062670512	Ga2-81	120
025680232	H -1-27	62	037301215	Z -4-3	114	060670612	A2 -38	4	062670612	C13-81	44
025680232	H -4	62	037521016	W -1-4	94	060670612	A3 -38	8	062670612	F -41	58
025680232	Ga2-8	120	037521016	W -45	96	060670612	F -16	58	062670612	F -54	58
025680232	Ga3-156	122	039411215	W -1-10	94	060670612	G -6	60	062670612	F -58	58
025680232	Ga4-156	124	047401442	M1 -6	72	060670612	AA1-2-1-9	104	062670612	G -4	60
025680232	Ga5-8	126	048020342	AA1-1-1-10	104	060670612	AA1-2-3	104	062670612	G -24	60
025710232	C5 -197	28	048030342	C1 -1-1-4	18	060680512	K -22	68	062670612	L -11	70
025750132	K -19	68	048030342	K -18	68	060680512	AA4-8-4	110	062670612	L -43	70
025770232	E -32	56	048040342	C1 -1-1-10	18	060680512	AA4-9-2	112	062670612	M1 -21	72
026030232	Z -101-1-5	116	048040342	C1 -1-2-16	18	060680712	C10-58	38	062670612	AA3-3-1-5	108
026040236	Q -32-8	82	048040342	C8 -1-16	34	060680712	C14-58	46	062670612	Ga5-81	126
026120236	W -1-2-1-9	94	048040342	C12-1-8	42	060680712	D1 -9	50	062670712	C1 -82	20
026120236	W -1-2-2-9	94	048040342	D2 -66	52	060681212	A1 -110	2	062670712	C8 -82	34
028030242	P -1-1-7	78	048040342	K -23	68	060681212	A2 -110	4	062670712	C13-82	44
028030242	P -1-2-7	78	048040342	L -18	70	060681212	A3 -110	8	062670812	AA3-4-5	108
028030242	Y1 -1-11-4	100	048040342	M1 -19	72	060681212	A3 -112	8	062671012	M1 -14	72
028030242	Y2 -1-11-4	102	048050342	C1 -1-1-16	18	060681212	A3 -115	8	062671016	Z -101-2	116
028030246	U1 -1-1-12	90	048050342	C1 -1-2-8	18	060681212	D1 -22	50	062671212	C1 -83	20
028030246	U1 -1-2-16	90	048050342	C8 -1-8	34	060681212	D1 -22	50	062671212	C8 -83	34
028030246	U2 -1-3-12	92	048050342	C12-1-16	42	060681212	D1 -22	50	062671212	C13-83	44
028040246	B2 -10-5	16	048050342	H -1-10	62	060681212	F -67	58	062680512	C1 -11	20
028040246	C3 -96	24	048050346	U1 -1-1-15	90	060681212	J -5	64	062680512	C8 -11	34
028040246	C10-96	38	048050346	U1 -1-2-19	90	061660806	Z -101-1-3	116	062680512	C12-11	42
028040246	C14-96	46	048050346	U2 -1-3-15	92	062020806	Q -32-4	82	062680512	H -1-18	62
028050246	C2 -61	22	048060142	U1 -1-2-3	90	062300612	AA1-2-1-2	104	062680512	AA3-3-1-9	108
028050246	C9 -61	36	048060342	C1 -1-1-27	18	062300612	AA1-2-1-6	104	062680512	Ga5-11	126
028050246	W -1-6	94	048060342	C2 -45	22	062300612	AA3-3-1-12	108	062680612	A3 -18	8
028050246	Z -34-8-2	115	048060342	C2 -54	22	062300616	Q -28	82	062680612	F -33	58
028060246	Q -24	82	048060342	C3 -109	24	062301205	U1 -1-1-6	90	062680612	H -3	62
028080240	W -11	96	048060342	C3 -116	24	062301205	U1 -1-2-10	90	062680712	B1 -16-1-8	12
028080242	B2 -113	16	048060342	C9 -45	36	062301205	U2 -1-3-6	92	062680712	B1 -16-2-8	12
028080242	B2 -116	16	048060342	C9 -54	36	062301616	AA1-1-1-13	104	062680712	B1 -16-3-8	14
028080242	P -20	80	048060342	C10-109	38	062302505	Y1 -1-11-3	100	062681012	A1 -28	2
028080246	P -33	80	048060342	C10-116	38	062302505	Y2 -1-11-3	102	062681012	A2 -28	4
028080246	W -1-2-1-4	94	048060342	C14-109	46	062302506	P -1-1-6	78	062681012	A3 -28	8
028080246	W -1-2-2-4	94	048060342	C14-116	46	062302506	P -1-2-6	78	062681212	D1 -32	50
028080246	W -1-2-5	94	048060342	J -32	64	062302506	U1 -1-2-25	90	062681212	D2 -63	52
028080246	W -1-2-10	94	048070342	E -18	54	062400612	A1 -40	2	062681212	H -2	62
028120246	W -1-2-1-10	94	048070342	J -19	64	062400612	A2 -40	4	062681412	V -6	92
028120246	W -1-2-2-10	94	048080342	C13-36	44	062400612	A3 -40	8	062710612	G -2	60
028350242	M1 -15	72	048100142	H -1-4	62	062400612	D1 -79	50	062710812	M1 -2	72
028350242	Y1 -1-8	100	048150142	B1 -9	12	062400616	Q -32-6	82	062710812	M2 -2	72
028350242	Y2 -1-8	102	048160242	C2 -52	22	062400806	V -2	92	062711012	A1 -23	2
028350242	AA1-2-1-8	104	048160242	C3 -114	24	062400812	A2 -112	4	062711012	A2 -23	4
028350242	Ga6-1-8	130	048160242	C9 -52	36	062400812	C3 -128	24	062711012	A3 -23	8
028680242	C3 -221	24	048160242	C10-114	38	062400812	C10-128	38	062711212	A1 -14	2
028680242	C3 -224	24	048160242	C10-142	38	062400812	C14-128	46	062711212	A2 -14	4
028680242	C10-221	38	048160242	C14-114	46	062401006	Z -3	114	062711212	A3 -14	8
028680242	C10-224	38	048160242	C14-142	46	062401216	Q -32-7	82	062711212	C2 -64	22
028680242	C14-221	46	048200142	C2 -27	22	062404005	Y1 -1-11-10	100	062711212	C9 -64	36
028680242	C14-224	46	048200142	C9 -27	36	062404005	Y2 -1-11-10	102	062711412	AA4-7-4	110
028680242	J -22-5	64	048200142	D1 -18	50	062660412	E -14-3	54	062760812	L -40	70
032361306	W -1-14	94	048220242	C13-37	44	062660712	E -14-7	54	062761012	A2 -122	4
032422003	P -36	80	052400606	U1 -1-1-16	90	062670412	G -31	60	062761012	A3 -122	8
032422003	Z -99	116	052400606	U1 -1-2-20	90	062670512	C1 -81	20	062761012	C3 -69	24
032422003	Z -93	116	052400606	U2 -1-3-16	92	062670512	C5 -201	28	062761012	C10-69	38
032461606	Z -57	115	060501016	D1 -25	50	062670512	C8 -81	34	062761012	C14-69	46

CODE	REF.NO	Page	CODE	REF.NO	Page	CODE	REF.NO	Page	CODE	REF.NO	Page
062761412	C2 -14	22	101121000	W -1-13	94	107415019	B1 -26	14	119707003	W -7	96
062761412	C9 -14	36	101572101	Z -28	115	107415021	B1 -26	14	119708001	W -8	96
062771012	L -13	70	101706001	E -6-1	54	107415023	B1 -26	14	120448001	H -1-13	62
070688850	C2 -44	22	102630001	B1 -18	14	107453001	D2 -47	52	120990001	H -1-14	62
070688850	C3 -108	24	102707002	C5 -202	28	107606001	G -14	60	121007001	J -42	64
070688850	C9 -44	36	103810002	E -31	56	107606001	G -21	60	122991001	Z -14	114
072630260	B1 -7	12	104449001	A1 -49	2	107779001	Z -29	115	123882001	E -30	56
081003670	E -12	54	104449001	A2 -49	4	107780001	Z -31	115	133172003	W -1-3	94
081003670	E -17	54	104449001	A3 -49	8	108802001	F -60	58	133180005	W -1-15	94
091170007	R -1-3	86	104450101	A1 -4	2	109239002	A1 -26	2	133188001	W -6	96
0A4300605	T -1-6	88	104450101	A1 -10	2	109239002	A2 -26	4	133740006	Z -54	115
0A4300605	T -1-12	88	104450101	A2 -4	4	109239002	A3 -26	8	139096001	C12-1-18-1	42
0A4301005	N -1-28-18	74	104450101	A2 -10	4	109714000	Z -5	114	140263000	D1 -30	50
0A4301005	R -1-11	86	104450101	A3 -4	8	109714000	Z -12	114	140327001	D1 -80	50
0A4400605	N -41	75	104450101	A3 -10	8	109714000	Z -21	114	140392009	A1 -7	2
0A5400805	T -1-5	88	104450101	B2 -129	16	109763002	L -15	70	140392009	A2 -7	4
0A5400806	F -7	58	104450101	D1 -71	50	110161004	J -37	64	140392009	A3 -7	8
0A5400806	N -1-6	74	104525001	G -14	60	110168001	C1 -1-2-18	18	140647101	L -42	70
0A5400806	AA4-7-7	110	104525001	AA2-2-6	106	110168001	C8 -1-18	34	140647101	Q -32-5	82
0A5401006	N -1-7	74	104567101	F -22	58	110168001	C12-1-11	42	140726000	B1 -6	12
0A5401006	Q -13	82	104821001	A1 -5	2	110233001	J -36	64	141492001	J -26-2	64
0A5401006	Q -33	84	104821001	A2 -5	4	110251001	F -28	58	141590001	H -1-25	62
0A5401006	Q -35	84	105812003	J -15	64	110251001	M1 -9	72	141786001	E -1	54
0A5401006	Q -37	84	106147002	L -38	70	110367001	J -31	64	142443001	Z -26	115
0A5401006	Q -39	84	106629002	A1 -21	2	110735001	K -17	68	142721001	Z -32	115
0A5401006	Q -41	84	106629002	A1 -31	2	111140002	J -50	66	142990001	Z -34-10-3	115
0A5401006	Q -44	84	106629002	A2 -21	4	111466101	D2 -56	52	143591001	C1 -1-1-15	18
0A5401006	Q -46	84	106629002	A2 -31	4	113006001	F -65	58	143591001	C1 -1-2-7	18
0A5401006	Q -55	84	106629002	A2 -114	4	113316001	G -5	60	143591001	C8 -1-7	34
0A5401206	N -1-30	74	106629002	A2 -116	4	113730001	AA4-8-3-5	110	143591001	C12-1-17	42
0A5401605	N -50	76	106629002	A3 -21	8	113730001	AA4-8-3-10	110	143882001	Z -9	114
0A5403006	N -1-5	74	106629002	A3 -31	8	114294001	G -9	60	143910009	Z -11	114
0A5501205	P -2	78	106629002	A3 -124	10	114483002	Z -22	114	144105000	H -1-23	62
0B1351606	Z -88	116	106629002	C2 -92	22	114486002	Z -6	114	144110001	H -1-21	62
0B1351606	Z -94	116	106629002	C3 -132	24	115186001	G -19	60	144226001	Z -50	115
100022004	H -1-26	62	106629002	C3 -135	24	115559002	D1 -33	50	144458001	B1 -23	14
100022005	J -25	64	106629002	C9 -92	36	115559002	W -3	96	144458001	K -27	68
100022005	J -26-3	64	106629002	C14-132	46	116694001	W -10	96	144504001	AA1-1-1-2	104
100032004	J -51	66	106629002	C14-135	46	116920001	B1 -8	12	144504001	AA2-2-1-11	106
100032004	AA4-7-2	110	107017001	T -1-21	88	116922001	G -12	60	144588001	G -10	60
100032004	AA4-8-2	110	107017002	A1 -37	2	117291002	Y1 -1-3	100	144712001	B1 -2-1	12
100090004	E -2	54	107017002	A2 -37	4	117291002	Y2 -1-3	102	145087001	Y1 -1-1-12	100
100136001	G -20	60	107017002	A3 -37	8	117363001	C5 -196	28	145087001	Y2 -1-1-12	102
100136001	H -1-20	62	107038003	C1 -84	20	117934001	A1 -6	2	145446001	G -16	60
100242003	B1 -20	14	107038003	C8 -84	34	117934001	A1 -11	2	145446001	G -22	60
100242003	Y1 -1-1-16	100	107038003	C13-84	44	117934001	A1 -22-3	2	145446001	H -1-22	62
100242003	Y2 -1-1-16	102	107149001	F -5	58	117934001	A2 -6	4	145465001	B1 -16-1-5	12
100250001	B1 -13	12	107149001	F -13	58	117934001	A2 -22-3	4	145465001	B1 -16-2-5	12
100250001	B1 -13	12	107272002	C10-132	38	117934001	A3 -6	8	145465001	B1 -16-3-5	12
100250001	B1 -13	12	107272002	C10-135	38	117934001	A3 -22-3	8	145472001	D2 -57	52
100281001	D1 -10	50	107321003	A1 -36	2	117934001	AA4-7-3-3	110	145478101	J -10	64
100360003	J -54	66	107321003	A2 -36	4	117936001	A1 -42	2	145478101	L -21	70
100402004	G -17	60	107321003	A3 -36	8	117936001	A2 -42	4	145519001	G -10	60
100402004	H -1-7	62	107321003	M1 -4	72	117936001	A3 -42	8	145547001	F -27	58
100645003	A1 -29	2	107321003	M2 -11	72	117936001	U1 -1-1-17	90	145646011	B1 -26	14
100645003	A2 -29	4	107321009	T -1-20	88	117936001	U1 -1-2-21	90	145646014	B1 -26	14
100645003	A3 -29	8	107415009	B1 -26	14	117936001	U2 -1-3-17	92	145646016	B1 -26	14
100645003	K -7	68	107415011	B1 -26	14	117936001	AA1-2-5	104	145646018	B1 -26	14
100659001	K -37	68	107415014	B1 -26	14	118064001	Z -33	115	145646019	B1 -26	14
100887001	Z -30	115	107415016	B1 -26	14	118837001	Z -27	115	145646019	B1 -26	14
101073001	W -1-12	94	107415018	B1 -26	14	119702004	W -1-11	94	145646024	B1 -26	14

索引 / INDEX

CODE	REF.NO	Page	CODE	REF.NO	Page	CODE	REF.NO	Page	CODE	REF.NO	Page
145646025	B1 -26	14	150592001	A2 -48	4	154237001	Y1 -1-1-14	100	417382001	T -1-3-5	88
146058001	AA1-1-1-4	104	150592001	A2 -53	4	154237001	Y2 -1-1-14	102	525567000	AA4-7-8	110
146058001	AA2-2-1-9	106	150592001	A3 -48	8	154237001	Ga6-1-1-14	130	525664000	Q -45-2	84
146059001	AA1-1-1-5	104	150592001	A3 -53	8	154252001	Y1 -1-4	100	525664000	AA4-7-6	110
146059001	AA2-2-1-8	106	152237101	B1 -16-2-4	12	154253001	Y1 -1-5	100	530138001	C2 -53	22
146060000	AA1-1-1-6	104	152242001	B1 -24	14	154256101	Y1 -1-9	100	530138001	C3 -115	24
146060000	AA2-2-1-7	106	152243001	B1 -25	14	154256101	Y2 -1-9	102	530138001	C9 -53	36
146080000	AA1-1-2	104	152245101	E -4	54	154256101	Ga6-1-9	130	530138001	C10-108	38
146206009	AA1-1-1-3	104	152632001	C7 -210-1-3	32	154467001	Z -4-2	114	530138001	C10-115	38
146206009	AA2-2-1-10	106	152632001	C7 -210-2-3	32	154514001	Q -32-9	82	530138001	C14-108	46
146288001	K -21	68	152632001	C7 -213-1	32	154528001	H -1-12	62	530138001	C14-115	46
146354001	C12-1-7	42	152632001	C15-165-1	48	154596000	J -21	64	554482000	Q -40	84
147777000	B1 -16-1-9	12	152632001	Ga5-165-1	128	154599000	J -6	64	623033000	D2 -44	52
147777000	B1 -16-2-9	12	152633001	C7 -210-1-4	32	154607101	L -10	70	625010000	AA1-2-2	104
147777000	B1 -16-3-9	14	152633001	C7 -210-2-4	32	154623000	B1 -12-3-1	12	J03647001	Q -30	82
148196000	D2 -52	52	152633001	C7 -213-2	32	154624101	B1 -16-3-4	12	J03663001	Q -30-1	82
148197000	D2 -53	52	152633001	C15-165-2	48	154763010	B1 -26	14	J03663-001	Wa -	131
148738000	F -4	58	152633001	Ga5-165-2	128	155510001	AA1-1-1-7	104	S00313001	D1 -72	50
148782001	C2 -30	22	152678201	E -11	54	155510001	AA2-2-1-6	106	S00554000	N -1-16	74
148782001	C9 -30	36	152678201	E -16	54	155559001	M1 -18	72	S00705001	J -47	66
148847001	C3 -222	24	152682101	E -21	54	155578000	B1 -21	14	S01005000	Z -34-4-4	115
148847001	C3 -225	24	152683101	E -14-4	54	156112003	Z -34-6	115	S01199003	W -5	96
148847001	C10-222	38	152684101	E -14-5	54	156206001	K -31	68	S01998001	M1 -8	72
148847001	C10-225	38	152686101	E -21	54	157237001	D2 -67-7	52	S02269001	B1 -22	14
148847001	C14-222	46	152718001	C2 -18	22	157237001	Ga1-F	118	S02354001	J -24	64
148847001	C14-225	46	152718001	C9 -18	36	157255100	AA1-1-1-8	104	S02429101	E -14-2	54
148847001	J -13	64	152718001	C13-18	44	157968001	H -1-17	62	S02438001	G -25-1	60
148847001	P -37	80	152869001	G -1	60	158592001	D2 -67-6	52	S02439001	G -25-2	60
149168001	C5 -194	28	152870001	G -3	60	158592001	Ga1-G	118	S02445001	A1 -32	2
149168001	C6 -166	30	152872001	G -8	60	159111001	K -39	68	S02445001	A2 -32	4
149287000	Q -36	84	152881001	G -27	60	159150000	A1 -12	2	S02445001	A3 -32	8
149287000	Q -38	84	152883000	G -29	60	159150000	A2 -12	4	S02617001	AA1-2-1-7	104
149287000	Q -43	84	152884001	G -30	60	159224001	G -7	60	S02652001	J -7	64
149287000	Q -45-1	84	152889001	G -23	60	159379001	D1 -35	50	S02654001	J -8-1	64
149287000	Q -54	84	152889001	AA1-2-4	104	159574101	H -1-19	62	S02657101	AA1-2-6	104
149287000	AA2-2-7	106	152891101	G -26	60	159805001	G -15	60	S02677001	K -26	68
149287000	AA3-3-5	108	152948001	F -35	58	159905001	J -14	64	S02678001	K -28	68
149482001	C12-4	42	152969001	F -57	58	181995001	E -6	54	S02680001	AA3-3-1-13	108
149796001	P -6	78	152969001	F -69	58	200190001	P -15	80	S02704001	A1 -109	2
149809000	N -43	76	153057102	C4 -141-3	26	200190001	Z -41	115	S02704001	A2 -109	4
149809000	N -48	76	153138001	AA4-7-1-6	110	218859001	Q -56	84	S02704001	A3 -109	8
149809000	S -3	86	153138001	AA4-7-1-9	110	228475000	J -55	66	S02739000	W -1-9	94
149809000	T -1-17	88	153242000	N -1-28-15	74	228475000	N -7	75	S02740000	W -1-8	94
149831101	Y1 -1-1-13	100	153242000	N -33	75	228475000	P -35	80	S02747101	Z -34-4-5	115
149831101	Y2 -1-1-13	102	153403002	C1 -9	20	228475000	Q -11	82	S02763502	Z -34	115
150172003	Z -34-5-1	115	153403002	C5 -155	28	228475000	Q -47	84	S02778002	Z -34-9	115
150173003	Z -34-7	115	153403002	C8 -9	34	228475000	U1 -1-1-7	90	S02787002	Z -34-10-1	115
150174000	Z -34-4-3	115	153403002	C11-155	40	228475000	U1 -1-2-11	90	S02907000	T -1-8	88
150174000	Z -34-5-2	115	153403002	C12-9	42	228475000	U2 -1-3-7	92	S02959101	C7 -210-1	32
150179002	Z -34-8-1	115	153403002	Ga2-9	120	228475000	AA3-4-6	108	S02960101	C7 -210-2	32
150182000	Z -34-2	115	153403002	Ga3-155	122	231071001	J -17	64	S02963201	C7 -209	32
150183000	Z -34-10-2	115	153403002	Ga4-155	124	232384001	N -1-28-7	74	S02966101	C7 -210-1-1	32
150206002	Z -34-4-1	115	153403002	Ga5-9	126	340400001	P -25	80	S02966101	C7 -210-2-1	32
150382001	Y2 -1-1-5	102	153596001	J -20	64	340400001	Q -25	82	S02967101	C7 -211	32
150451001	AA4-7-1-5	110	153843009	Z -86	116	340400001	Q -42	84	S02968000	C7 -210-1-2	32
150460001	D2 -45	52	153871001	C5 -199	28	340400001	Y1 -1-12	100	S02969000	C7 -212-1	32
150461001	D2 -46	52	153924001	F -47	58	340400001	Y2 -1-12	102	S02970000	C7 -212-2	32
150592001	A1 -47	2	154235001	Y1 -1-1-10	100	340400001	AA2-2-5	106	S02971000	C7 -210-2-2	32
150592001	A1 -48	2	154235001	Y2 -1-1-10	102	340400001	AA3-3-4	108	S03677001	D2 -69	52
150592001	A1 -53	2	154236001	Y1 -1-1-11	100	340400001	Z -96	116	S03800001	C1 -1-2-15	18
150592001	A2 -47	4	154236001	Y2 -1-1-11	102	402887001	E -14-6	54	S03800001	C8 -1-15	34

CODE	REF.NO	Page	CODE	REF.NO	Page	CODE	REF.NO	Page	CODE	REF.NO	Page
S03801101	C1 -1-2-17	18	S10065001	Ga5-10	126	S10243000	Q -34	84	S12640009	Y1 -1-1-20	100
S03801101	C8 -1-17	34	S10069301	C2 -12-2	22	S10244000	Q -22-1	82	S12640009	Y2 -1-1-20	102
S03803000	Y1 -1-13	100	S10069301	C9 -12-2	36	S10371001	D2 -64	52	S12641009	Y1 -1-1-4	100
S03803000	Y2 -1-13	102	S10077100	C2 -32	22	S10372100	D2 -65	52	S12642009	Y1 -1-1-19	100
S04897000	AA2-5-1-4	106	S10077100	C9 -32	36	S10379001	C1 -1-2-12	18	S12642009	Y2 -1-1-19	102
S04897000	AA2-5-2-4	106	S10078001	C2 -33	22	S10379001	C8 -1-12	34	S12643001	Y1 -1-2	100
S04897000	AA3-4-4	108	S10078001	C3 -121	24	S10408000	T -8	88	S12644001	Y1 -5	100
S04897000	AA4-9-4	112	S10078001	C9 -33	36	S10445000	C4 -141-1-1	26	S12645001	Y1 -1-10	100
S05223001	W -1-2-1-6	94	S10078001	C10-121	38	S10446000	C4 -141-1-2	26	S12668001	K -35	68
S05223001	W -1-2-2-6	94	S10078001	C14-121	46	S10447000	C4 -141-2-1	26	S12699000	G -11	60
S05665001	Y1 -1-1-9	100	S10079101	C2 -34	22	S10448000	C4 -141-2-2	26	S13006101	C6 -158	30
S05665001	Y2 -1-1-9	102	S10079101	C3 -122	24	S10449000	C4 -141-2-3	26	S13006101	Ga2-158	120
S05670002	P -40-1-1	80	S10079101	C9 -34	36	S10450000	C4 -141-1-3	26	S13007001	C6 -159	30
S06548001	G -14	60	S10087101	C3 -112	24	S10451000	C4 -141-2-4	26	S13007001	C15-157	48
S06706001	Z -15	114	S10091201	C3 -65	24	S10452000	C4 -141-1-6	26	S13007001	Ga2-159	120
S07333001	F -2	58	S10091201	C10-65	38	S10453000	C4 -141-2-5	26	S13007001	Ga5-157	128
S07818009	Q -26	82	S10091201	C14-65	46	S10454000	C4 -141-1-4	26	S13090001	C6 -168	30
S08030000	N -1-28-16	74	S10105001	D1 -20	50	S10455000	C4 -141-2-6	26	S13091001	C6 -169	30
S08030000	N -32	75	S10108001	D1 -31	50	S10456000	C4 -141-1-7	26	S13092001	C6 -167	30
S08140000	AA2-5-1-3	106	S10109001	D1 -34	50	S10457000	C4 -141-2-7	26	S13096001	C6 -171	30
S08140000	AA2-5-2-3	106	S10110101	D1 -36	50	S10458000	C4 -141-1-5	26	S13097001	C6 -172	30
S09043000	E -14-8	54	S10111101	D2 -60	52	S10459000	C4 -141-2-8	26	S13098001	C6 -170	30
S09043000	F -34	58	S10112001	D2 -61	52	S10460000	C4 -141-1-8	26	S13099001	C4 -203	26
S09043000	F -59	58	S10113301	D2 -62	52	S10461000	C4 -141-2-9	26	S13099001	Y1 -2	100
S09216002	W -1-2-1-1	94	S10125000	D1 -40	50	S10469001	G -18	60	S13100001	C4 -204	26
S09217102	W -1-2-1-2	94	S10133000	C3 -110	24	S10470101	K -20	68	S13100001	Y1 -3	100
S09221002	W -1-2-2-1	94	S10134001	C3 -111	24	S10472001	Z -75	116	S13385001	K -32	68
S09222102	W -1-2-2-2	94	S10140109	C2 -91	22	S10478000	F -10	58	S13399001	D2 -68	52
S09224002	P -30	80	S10140109	C9 -91	36	S10542001	Y1 -6	100	S13807000	C4 -141-2	26
S09224002	W -1-2-7	94	S10141109	A1 -17	2	S10542001	Y2 -13	102	S14069001	C5 -198	28
S09225001	P -31	80	S10141109	A2 -17	4	S10542001	Ga6-13	130	S14073001	C5 -200	28
S09225001	W -1-2-8	94	S10162201	F -15	58	S10661109	W -1-2-1-8	94	S14252001	C6 -164	30
S09226001	P -34	80	S10174000	H -1-15	62	S10661109	W -1-2-2-8	94	S14252001	Ga2-164	120
S09226001	W -1-2-11	94	S10195101	J -30	64	S11244001	J -52	66	S14253001	C6 -163	30
S09228000	P -1-1-4	78	S10202201	J -41	64	S11426000	AA4-7-1-2-2	110	S14253001	Ga2-163	120
S09228000	P -1-2-4	78	S10203201	J -43	64	S11438101	J -43	64	S14254001	C6 -161	30
S09312001	W -1-2-1-5	94	S10204101	J -44	66	S11884001	AA1-2-1-5	104	S14255001	C6 -162	30
S09312001	W -1-2-2-5	94	S10205001	J -45-1	66	S12004000	C1 -1-1-22	18	S14386000	C15-161	48
S09318101	P -1-1-2	78	S10208001	J -46	66	S12004000	C1 -1-2-19	18	S14386000	Ga5-161	128
S09318101	P -1-2-2	78	S10208001	Z -18	114	S12004000	C8 -1-19	34	S14387000	C15-161	48
S09393002	P -40-2-1	80	S10208002	J -46	66	S12104000	AA2-5-1-2	106	S14387000	Ga5-161	128
S09639009	W -1-2-1	94	S10208002	Z -18	114	S12104000	AA2-5-2-2	106	S14388101	C15-160	48
S09640009	W -1-2-2	94	S10208003	J -46	66	S12150000	M2 -3-3	72	S14388101	Ga5-160	128
S09989000	Z -72	116	S10208003	Z -18	114	S12150000	AA2-2-1-3	106	S14389000	C15-163	48
S10030002	A1 -24	2	S10208004	J -46	66	S12212000	P -10	78	S14389000	Ga5-163	128
S10030002	A2 -24	4	S10209101	J -48	66	S12212000	P -10	78	S14390000	C15-163	48
S10030002	A3 -24	8	S10210201	J -49-1	66	S12404000	P -1-1-5-2-1	78	S14390000	Ga5-163	128
S10040001	B1 -12-2-1	12	S10211001	J -53-1	66	S12404000	P -1-2-5-2-1	78	S14392201	C15-159	48
S10047001	C1 -1-1-2	18	S10211001	Ga1-A	118	S12441001	G -33	60	S14392201	Ga5-159	128
S10048001	C1 -1-1-3	18	S10212101	J -53-3	66	S12633209	Y1 -1-1	100	S14598001	C7 -208	32
S10049001	C1 -1-1-5	18	S10212101	Ga1-E	118	S12634009	Y1 -1-1-1	100	S14598001	Y1 -4	100
S10050000	C1 -1-1-6	18	S10213001	J -53-5	66	S12634009	Y2 -1-1-1	102	S14846001	C6 -165	30
S10053001	C1 -1-1-9	18	S10213001	Ga1-F	118	S12635009	Y1 -1-1-2	100	S14848001	C5 -192	28
S10058001	C1 -1-1-13	18	S10214109	AA3-3-1-3	108	S12635009	Y2 -1-1-2	102	S14849001	C5 -193	28
S10058001	C1 -1-2-5	18	S10217101	K -16	68	S12636001	Y1 -1-1-3	100	S15031008	AA2-2-4	106
S10058001	C8 -1-5	34	S10219001	L -1	70	S12637009	Y1 -1-1-17	100	S15031008	AA3-3-3	108
S10059001	C1 -1-1-20	18	S10221001	L -7	70	S12637009	Y2 -1-1-17	102	S15031008	AA3-4-2	108
S10065001	C1 -10	20	S10229101	L -17	70	S12638009	Y1 -1-1-6	100	S15031008	AA4-7-5	110
S10065001	C8 -10	34	S10230000	L -33	70	S12638009	Y2 -1-1-6	102	S15031008	AA4-9-1-5	112
S10065001	C12-10	42	S10231001	L -35	70	S12639001	Y1 -1-1-18	100	S15158009	W -1-7	94
S10065001	Ga2-10	120	S10232001	L -39	70	S12639001	Y2 -1-1-18	102	S15665001	E -25	56

索引 / INDEX

CODE	REF.NO	Page	CODE	REF.NO	Page	CODE	REF.NO	Page	CODE	REF.NO	Page
S15665001	Z -16	114	S20289101	X -3-3	98	S30925001	J -53-4	66	S37995101	H -1-6	62
S15666001	E -25	56	S20289101	X -4-1	98	S30925001	Ga1-ED	118	S37996001	H -1-8	62
S15666001	Z -16	114	S20293101	X -3-4	98	S30926001	J -53-6	66	S37997001	H -1-11	62
S15667001	E -24-3	54	S20293101	X -5-1	98	S30926001	Ga1-FD	118	S37998001	H -1-16	62
S15667001	E -24-3	54	S20822101	X -4	98	S30950000	C12-1-4	42	S38002301	J -3	64
S16075101	E -24-1	54	S20823101	X -5	98	S30951001	C12-1-9	42	S38004002	J -11	64
S16290001	E -23	54	S20878000	M1 -22	72	S31012001	D2 -58	52	S38004003	J -11	64
S16492101	E -24-2	54	S21775001	C1 -1-1-14	18	S31013001	D2 -59	52	S38004004	J -11	64
S16492101	E -24-2	54	S21775001	C1 -1-2-6	18	S31032001	G -13	60	S38005001	J -16	64
S16996000	AA4-9-1-2	112	S21775001	C8 -1-6	34	S31365001	C5 -191	28	S38011001	J -34	64
S16997100	AA4-9-1-4	112	S21775001	C12-1-18	42	S31551209	P -1-1-1	78	S38029000	U1 -1-1-5	90
S17813001	C12-1-14	42	S21875001	K -34	68	S31551209	P -1-2-1	78	S38030000	U1 -1-1-5-1	90
S17815000	C12-2	42	S23446000	C13-34	44	S31554109	AA1-6-5	104	S38039209	Z -4	114
S17816001	C12-1-22	42	S23660000	M2 -3-2	72	S31570409	Y1 -1-11-1	100	S38040209	Z -4-1	114
S17868001	C13-32	44	S23818001	C6 -173	30	S31570409	Y2 -1-11-1	102	S38043009	Z -20	114
S17871101	D2 -49	52	S23819001	C6 -174	30	S31612001	J -45-4	66	S38059000	K -11	68
S17885101	C10-106	38	S23820001	C6 -175	30	S31760000	N -1-17	74	S38059000	U1 -1-1-20	90
S17885101	C14-106	46	S23821001	C6 -176	30	S31776109	AA3-3-1-8	108	S38059000	U1 -1-2-24	90
S17886100	C10-110	38	S23822001	C6 -177	30	S31777001	AA3-3-1-2	108	S38059000	U2 -1-3-20	92
S17886100	C14-110	46	S23823001	C6 -178	30	S31778000	AA3-3-1-6	108	S38060000	U1 -1-1-19	90
S17887001	C10-111	38	S23824001	C6 -179	30	S31779001	AA3-3-1-7	108	S38060000	U1 -1-2-23	90
S17887001	C14-111	46	S23825001	C6 -180	30	S32235001	J -18	64	S38060000	U2 -1-3-19	92
S17888001	C10-112	38	S23826001	C6 -181	30	S32259001	M2 -8	72	S38080001	V -4	92
S17888001	C14-112	46	S23827001	C6 -182	30	S33006001	Z -51	115	S38082001	V -5	92
S17901000	F -64	58	S23828001	C6 -183	30	S33533101	C7 -209-1	32	S38093000	N -1-29	74
S17942100	AA3-3-1-1	108	S23829001	C6 -184	30	S34348001	J -53-9	66	S38094100	N -1-4	74
S18027101	AA3-4-1	108	S23830001	C6 -185	30	S34348001	Ga1-M	118	S38104000	T -1-3-4	88
S18032001	AA1-1-1-1	104	S23831001	C6 -186	30	S34413000	N -1-26	74	S38107100	N -1-10	74
S18037009	AA1-1-1-12	104	S23832001	C6 -187	30	S34533001	AA2-2-1-4	106	S38108000	N -1-11	74
S18093100	Z -4-4	114	S23833001	C6 -188	30	S34534101	AA2-2-1-5	106	S38109100	N -1-12	74
S18382000	AA4-9-1-3	112	S23834001	C6 -189	30	S34536101	AA2-2-1-12	106	S38110000	N -1-13	74
S18415101	C1 -1-2-14	18	S23835001	C6 -190	30	S34706000	AA2-2-1-1	106	S38112001	N -2-1	75
S18415101	C8 -1-14	34	S23836001	J -8	64	S34883001	M1 -11	72	S38114000	N -2-2	75
S18415101	P -1-1-5-1-3	78	S23880000	P -1-1-10	78	S34986000	F -11	58	S38117000	N -2-3	75
S18415101	P -1-2-5-1-3	78	S23880000	P -1-2-9	78	S35183000	C2 -26	22	S38120000	N -2-5	75
S18415101	Y1 -1-1-25	100	S24511007	B1 -26	14	S35183000	C9 -26	36	S38123000	N -3-1	75
S18415101	Y1 -1-11-8	100	S24612001	X -1	98	S35183000	C12-1-2	42	S38148000	Q -12	82
S18415101	Y2 -1-1-25	102	S25100000	P -26	80	S35183000	D1 -17	50	S38155000	R -1-7	86
S18415101	Y2 -1-11-8	102	S25127001	J -53-8	66	S35722200	C2 -47	22	S38166000	U1 -1-1-1	90
S18415101	AA1-6-4	104	S25127001	Ga1-L	118	S35722200	C9 -47	36	S38166000	U1 -1-2-1	90
S18415101	AA2-2-2-4	106	S25456001	K -3	68	S36008009	T -1-19	88	S38166000	U2 -1-3-1	92
S18415101	AA3-3-1-4	108	S25456001	K -14	68	S36260000	U1 -1-1-5-2	90	S38167001	U1 -1-2-2	90
S18415101	AA3-3-2-1-3	108	S25634101	C2 -62	22	S36260000	U1 -1-2-9-2	90	S38168001	U1 -1-2-5	90
S18415101	AA3-4-3-4	108	S25634101	C9 -62	36	S36260000	U2 -1-3-5-2	92	S38170001	U1 -1-1-4	90
S18636101	C12-1-23	42	S25634101	T -5	88	S37037001	Z -34-11-4	115	S38170001	U1 -1-2-8	90
S18641009	Z -85	116	S27844201	C2 -42	22	S37038001	Z -34-11-2	115	S38170001	U2 -1-3-4	92
S19543001	AA4-8-3-7	110	S27844201	C2 -50	22	S37038001	Z -34-11-3	115	S38174000	U1 -1-1-8	90
S19629001	C7 -209-2	32	S27844201	C3 -106	24	S37059001	N -1-23	74	S38174000	U1 -1-2-12	90
S19662001	D1 -12	50	S27844201	C9 -42	36	S37059-001	Wa -	131	S38174000	U2 -1-3-8	92
S19736001	A3 -113	8	S27844201	C9 -50	36	S37060001	N -1-24	74	S38175001	U1 -1-1-9	90
S19736001	A3 -116	8	S28741000	Y1 -1-14	100	S37060-001	Wa -	131	S38175001	U1 -1-2-13	90
S19748001	M1 -5	72	S28741000	Y2 -1-14	102	S37064101	B1 -12-2	12	S38175001	U2 -1-3-9	92
S19748001	M1 -12	72	S29023000	T -1-3-1	88	S37928019	B1 -26	14	S38176101	U1 -1-1-10	90
S19817001	AA4-7-1-8	110	S29468100	AA1-2-1-4	104	S37929009	B1 -26	14	S38176101	U1 -1-2-14	90
S20164001	A1 -34	2	S29710000	P -1-2-3	78	S37929016	B1 -26	14	S38176101	U2 -1-3-10	92
S20164001	A2 -34	4	S29997001	J -53-2	66	S37968001	D1 -11	50	S38177001	U1 -1-1-14	90
S20164001	A3 -34	8	S29997001	Ga1-D	118	S37978251	E -5	54	S38177001	U1 -1-2-18	90
S20280101	X -3-1	98	S30015101	C5 -195	28	S37983001	F -6	58	S38177001	U2 -1-3-14	92
S20280101	X -6-1	98	S30128001	J -49-2	66	S37992100	H -1-2	62	S38180000	U1 -1-1-18	90
S20286101	X -3-2	98	S30450001	J -53-7	66	S37993000	H -1-3	62	S38180000	U1 -1-2-22	90
S20286101	X -6-2	98	S30450001	Ga1-H	118	S37994001	H -1-5	62	S38180000	U2 -1-3-18	92

CODE	REF.NO	Page	CODE	REF.NO	Page	CODE	REF.NO	Page	CODE	REF.NO	Page
S38203000	N -1-28-5	74	S42691000	R -1-2	86	S42798001	C8 -77	34	S42882001	Z -58	116
S38205000	N -1-28-9	74	S42747201	D1 -13	50	S42798001	C13-77	44	S42883001	D1 -78	50
S38208000	N -1-28-14	74	S42750209	A1 -22	2	S42798001	Ga2-77	120	S42884001	C1 -76	20
S38352101	N -20	75	S42750209	A2 -22	4	S42798001	Ga5-77	126	S42884001	C8 -76	34
S38352101	Wa -	131	S42750209	A3 -22	8	S42799001	C1 -78	20	S42884001	C13-76	44
S38353101	N -21	75	S42751109	A1 -22-1	2	S42799001	C8 -78	34	S42884001	Ga2-76	120
S38353101	Wa -	131	S42751109	A2 -22-1	4	S42799001	Ga2-78	120	S42888001	C1 -138	20
S38357001	A1 -119	2	S42751109	A3 -22-1	8	S42800001	C1 -79	20	S42888001	Ga3-138	122
S38357001	A2 -124	6	S42752000	A1 -22-2	2	S42800001	C8 -79	34	S42890001	Z -92	116
S38357001	A3 -129	10	S42752000	A2 -22-2	4	S42800001	C13-79	44	S43126000	R -1-1	86
S38357001	Z -1-2	114	S42752000	A3 -22-2	8	S42800001	Ga2-79	120	S43170109	N -1-1	74
S38357001	Wa -	131	S42756101	B1 -16-1-7	12	S42800001	Ga5-79	126	S43171009	N -1-2	74
S38357002	A1 -118	2	S42756101	B1 -16-2-7	12	S42801101	C1 -73	20	S43172009	N -1-3	74
S38357002	A2 -123	6	S42756101	B1 -16-3-7	12	S42801101	C8 -73	34	S43175000	N -1-28-11	74
S38357002	A3 -128	10	S42758001	A1 -39	2	S42801101	Ga2-73	120	S43176000	N -1-28-12	74
S38357002	Wa -	131	S42758001	A2 -39	4	S42802101	C1 -80	20	S43177000	N -1-28-1	74
S38571001	A1 -119	2	S42758001	A3 -39	8	S42802101	C8 -80	34	S43178000	R -1-4	86
S38571001	A2 -124	6	S42761000	C1 -1-1-1	18	S42802101	Ga2-80	120	S43181000	N -1-28-13	74
S38571001	A3 -129	10	S42761000	C1 -1-2-1	18	S42803001	C4 -141	26	S43184000	N -1-28-2	74
S38571001	Z -1-2	114	S42761000	C8 -1-1	34	S42806001	C4 -141	26	S43186000	N -1-15	74
S38571001	Wa -	131	S42764001	C1 -1-1-11	18	S42808001	C4 -141	26	S43187000	N -1-28-20	74
S38571002	A1 -118	2	S42764001	C1 -1-2-2	18	S42810001	C4 -141	26	S43188000	N -2-6	75
S38571002	A2 -123	6	S42764001	C8 -1-2	34	S42812001	C4 -141	26	S43189000	N -1-28-19	74
S38571002	A3 -128	10	S42767001	C1 -1-1-21	18	S42816201	C2 -12-1	22	S43196000	Q -3	82
S38571002	Wa -	131	S42768101	C1 -1-2	18	S42816201	C9 -12-1	36	S43197000	Q -4	82
S38648001	Z -34-4-2	115	S42768101	C8 -1	34	S42817101	C3 -86	24	S43201000	N -3-4	75
S38744101	Q -32-2	82	S42769001	C1 -1-2-3	18	S42827200	F -24	58	S43202000	Q -22	82
S39973001	B1 -12-2-3	12	S42769001	C8 -1-3	34	S42838101	U1 -1-1	90	S43203000	AA3-3-1-10	108
S40214001	D2 -67-10	52	S42770001	C1 -1-2-4	18	S42839101	D2 -51	52	S43205000	Q -14-2	82
S40214001	Ga1-A-CUT	118	S42770001	C8 -1-4	34	S42842101	U1 -1-2	90	S43206000	Q -20	82
S40217001	J -53-11	66	S42772001	C1 -6	20	S42843001	D2 -67-1	52	S43224000	T -1-10	88
S40217001	Ga1-3サカリ	118	S42772001	Ga2-6	120	S42843001	Ga1-A	118	S43225000	T -1-11	88
S40616001	N -40-1	75	S42773001	C1 -7	20	S42844001	D2 -67-2	52	S43228000	T -1-14	88
S40621000	N -44	76	S42773001	Ga2-7	120	S42844001	Ga1-B	118	S43236009	T -2	88
S40621000	S -2	86	S42774301	C2 -12	22	S42845001	D2 -67-3	52	S43237100	T -1-7	88
S40622000	N -45	76	S42774301	C9 -12	36	S42845001	Ga1-C	118	S43249101	S -1	86
S40623000	N -49	76	S42775101	C3 -130	24	S42846001	D2 -67-4	52	S43250100	S -1-1	86
S40624000	N -40-2	75	S42776101	C3 -133	24	S42846001	Ga1-D	118	S43251000	S -1-2	86
S40628000	P -1-1-3	78	S42778000	C2 -12-4	22	S42847001	D2 -67-5	52	S43252000	S -1-3	86
S40629000	P -1-1-9	78	S42778000	C9 -12-4	36	S42847001	Ga1-E	118	S43253000	S -1-4	86
S40635001	N -40	75	S42779001	C2 -12-5	22	S42848001	D2 -67-8	52	S43254100	S -1-5	86
S40764000	N -46	76	S42779001	C9 -12-5	36	S42848001	Ga1-J	118	S43255000	S -1-7	86
S40934101	J -45-2	66	S42784100	C2 -39	22	S42849101	D2 -67-9	52	S43256000	S -1-8	86
S41202151	Q -27	82	S42784100	C9 -39	36	S42849101	Ga1-XA	118	S43259101	S -1-18	86
S41205001	K -2	68	S42785001	C2 -55	22	S42856001	J -40	64	S43267000	S -1-14	86
S41206001	K -1	68	S42785001	C9 -55	36	S42858001	K -15	68	S43268000	S -1-15	86
S41222101	Z -90	116	S42787001	C1 -75	20	S42859001	K -29	68	S43269000	S -1-19	86
S41239001	D1 -15	50	S42787001	C8 -75	34	S42864101	K -30	68	S43270000	S -1-16	86
S41271000	C1 -1-2-21	18	S42787001	C13-75	44	S42867001	U1 -1-1-2	90	S43271000	S -1-11	86
S41271000	C8 -1-21	34	S42787001	Ga2-75	120	S42867001	U1 -1-2-6	90	S43272000	S -1-12	86
S41523000	AA4-7-1-2-3	110	S42790000	C3 -101	24	S42867001	U2 -1-3-2	92	S43273000	Z -71	116
S41524000	AA4-7-1-2-4	110	S42791101	C3 -103	24	S42868001	L -9	70	S43275000	N -1-18	74
S42258000	U1 -1-2-9-1	90	S42792001	C3 -105	24	S42870201	L -12	70	S43276000	N -1-19	74
S42259000	U1 -1-2-9	90	S42793000	C3 -120	24	S42871201	L -14	70	S43277000	N -1-20	74
S42260000	N -1-8	74	S42795101	C3 -125	24	S42873101	L -16	70	S43278000	P -40-1-2	80
S42446001	L -2	70	S42795101	C10-125	38	S42875000	A1 -18	2	S43278000	P -40-2-2	80
S42653000	N -42	75	S42795101	C14-125	46	S42876000	A1 -19	2	S43279300	AA1-2-1-1	104
S42653000	N -42	76	S42796001	C3 -127	24	S42877101	A1 -20	2	S43309000	N -1-22	74
S42653000	N -47	76	S42796001	C10-127	38	S42878000	C1 -1-2-13	18	S43318000	N -1-27	74
S42653000	T -1-16	88	S42796001	C14-127	46	S42878000	C8 -1-13	34	S43369000	N -3-2	75
S42658000	Z -73	116	S42798001	C1 -77	20	S42880001	D2 -73	52	S43370000	N -3-3	75

索引 / INDEX

CODE	REF.NO	Page	CODE	REF.NO	Page	CODE	REF.NO	Page	CODE	REF.NO	Page
S43671109	W -1-2	94	S43835100	AA1-1-1-11	104	S44624000	C14-120	46	S47592000	N -2-4	75
S43672209	W -1-2-3	94	S43836301	AA1-2	104	S44626009	A2 -101	4	S47594000	N -2-7	75
S43674000	T -3	88	S43837101	AA2-2	106	S44669001	C13-41	44	S47668000	N -1-28-4	74
S43675000	T -4	88	S43838101	AA2-2-1	106	S44745109	Y1 -1-11	100	S48534009	A3 -19	8
S43677001	C1 -85	20	S43839105	AA2-2-2	106	S44745109	Y2 -1-11	102	S48537009	A3 -20	8
S43677001	C8 -85	34	S43839108	AA3-4-3	108	S44746100	P -28-1	80	S48540109	A3 -103	8
S43678109	P -1-1	78	S43841109	AA3-3	108	S44746100	Y1 -1-11-7-1	100	S48555000	C15-152	48
S43679101	P -1-1-5	78	S43842109	AA3-3-1	108	S44746100	Y2 -1-11-7-1	102	S48555000	Ga5-152	126
S43679101	P -1-2-5	78	S43843009	AA3-3-1-11	108	S44746100	AA1-6-2-1	104	S48578000	R -1-10	86
S43680001	P -1-1-5-1	78	S43844101	AA3-3-2-1	108	S44746100	AA2-2-2-2-1	106	S48579000	T -1-3-2	88
S43680001	P -1-2-5-1	78	S43846009	AA3-4	108	S44746100	AA3-4-3-2-1	108	S48580000	N -1-28-17	74
S43682100	P -1-1-5-2	78	S43847201	AA1-6	104	S44748001	Y1 -1-11-2	100	S48580000	N -34	75
S43682100	P -1-2-5-2	78	S43977201	AA1-2-1	104	S44748001	Y2 -1-11-2	102	S48664001	E -24-1	54
S43683001	P -1-1-5-1-2	78	S43979001	AA2-5-1	106	S44748001	AA2-2-2-3	106	S48666001	V -1	92
S43683001	P -1-2-5-1-2	78	S43980001	AA2-5-1-1	106	S44748001	AA3-3-2-1-2	108	S49071000	N -1-28-8	74
S43683001	P -27	80	S43981000	S -1-17	86	S44748001	AA3-4-3-3	108	S49443000	U2 -3	92
S43683001	Y1 -1-11-6	100	S43986201	C1 -205	20	S44749001	AA1-6-3	104	S49448001	D2 -67-11	52
S43683001	Y2 -1-11-6	102	S43986201	Ga3-205	122	S44750100	P -28-2	80	S49448001	Ga1-B-L	118
S43683001	AA1-6-1	104	S43987001	C1 -206	20	S44750100	Y1 -1-11-7-2	100	S49471000	R -1-8	86
S43683001	AA2-2-2-1	106	S43987001	Ga3-206	122	S44750100	Y2 -1-11-7-2	102	S49472000	N -1-28-21	74
S43683001	AA3-3-2-1-1	108	S44313101	A3 -17	8	S44750100	AA1-6-2-2	104	S49484000	R -1-6	86
S43683001	AA3-4-3-1	108	S44317009	A3 -101	8	S44750100	AA2-2-2-2-2	106	S49485000	R -1-5	86
S43684001	P -1-1-5-1-1	78	S44320101	A3 -111	8	S44750100	AA3-3-2-1-6	108	S49582001	B1 -3	12
S43684001	P -1-2-5-1-1	78	S44321101	A3 -114	8	S44750100	AA3-4-3-2-2	108	S49586000	N -1-28-3	74
S43686000	P -1-1-11	78	S44322101	A3 -121	8	S44757101	C10-57	38	S49587001	B1 -16-1-1	12
S43687001	P -8-1	78	S44326001	C12-1-6	42	S44757101	C14-57	46	S49588001	B1 -16-1-2	12
S43687002	P -8-2	78	S44327001	C12-1-12	42	S44759000	AA3-3-2-1-4	108	S49589001	B1 -16-1-4	12
S43688001	P -9-1	78	S44328001	C12-1-13	42	S44760100	AA3-3-2-1-5	108	S49593000	B1 -19	14
S43688002	P -9-2	78	S44329001	C12-1-15	42	S44793009	Y1 -1	100	S49602201	Z -101	116
S43693000	D2 -43	52	S44372000	Q -2	82	S44794001	X -3	98	S49609001	E -13	54
S43694109	P -1-2	78	S44381001	C12-12-5	42	S44805101	U2 -1-3	92	S49620000	F -17	58
S43696100	P -28	80	S44382201	C3 -97	24	S44806000	U2 -1-3-5	92	S49622000	F -19	58
S43696100	Y1 -1-11-7	100	S44382201	C10-97	38	S44807000	U2 -1-3-5-1	92	S49624000	F -39	58
S43696100	Y2 -1-11-7	102	S44412001	AA2-5-2-1	106	S44924001	C3 -126	24	S49630001	D1 -1	50
S43696100	AA1-6-2	104	S44424001	Y2 -1-1-26	102	S44924001	C10-126	38	S49631001	D1 -2	50
S43696100	AA2-2-2-2	106	S44433401	C12-12	42	S44924001	C14-126	46	S49632001	D1 -3	50
S43696100	AA3-4-3-2	108	S44434101	C12-12-2	42	S45252000	Y1 -1-11-9	100	S49635001	D1 -4	50
S43700001	C5 -151-1	28	S44436000	C12-12-4	42	S45252000	Y2 -1-11-9	102	S49637001	D1 -6	50
S43700001	Ga3-151-1	122	S44437401	C12-12-1	42	S45253000	Y1 -1-11-9-1	100	S49638001	D1 -7	50
S43821001	C5 -151-2	28	S44443001	C13-30	44	S45253000	Y2 -1-11-9-1	102	S49641001	D1 -74	50
S43821001	Ga3-151-2	122	S44450001	AA2-5-2	106	S45254000	Y1 -1-11-9-2	100	S49641001	D1 -74	50
S43822001	C5 -151-3	28	S44456000	C10-101	38	S45254000	Y2 -1-11-9-2	102	S49643001	D1 -8	50
S43822001	Ga3-151-3	122	S44456000	C14-101	46	S45603001	C11-152	40	S49650001	J -29	64
S43823000	C5 -152	28	S44457000	C10-102	38	S45603001	Ga4-152	124	S49651001	J -35	64
S43823000	Ga3-152	122	S44457000	C14-102	46	S45724009	Z -19	114	S49660101	M1 -3	72
S43824001	C5 -153-1	28	S44458101	C10-103	38	S46255000	P -13	80	S49661101	M1 -7	72
S43824001	Ga3-153-1	122	S44458101	C14-103	46	S46405000	F -25	58	S49663001	M1 -13	72
S43825001	C5 -153-2	28	S44459001	C10-105	38	S46842001	AA4-8-3-3	110	S49664000	M1 -20	72
S43825001	Ga3-153-2	122	S44459001	C14-105	46	S46842001	AA4-8-3-8	110	S49685000	E -14-11	54
S43826001	C5 -153-3	28	S44483001	Z -101-1-1	116	S47089001	B1 -16-2-1	12	S49689001	B1 -16-1-6	12
S43826001	Ga3-153-3	122	S44485001	Z -101-1-2	116	S47089001	B1 -16-3-1	12	S49689001	B1 -16-2-6	12
S43827001	C5 -153-4	28	S44486101	Z -101-1-6	116	S47090001	B1 -16-2-2	12	S49689001	B1 -16-3-6	12
S43827001	Ga3-153-4	122	S44493101	Z -101-1	116	S47090001	B1 -16-3-2	12	S49938000	T -1-2	88
S43828001	C5 -153-5	28	S44605009	A2 -103	4	S47091001	B1 -16-1-3	12	S49939101	N -1-28	74
S43828001	Ga3-153-5	122	S44606001	A2 -105	4	S47091001	B1 -16-2-3	12	S49955101	C1 -139	20
S43829001	C5 -153-6	28	S44606001	A3 -105	8	S47091001	B1 -16-3-3	12	S49955101	C8 -139	34
S43829001	Ga3-153-6	122	S44607001	A2 -121	4	S47112000	C13-26	44	S49955101	Ga5-139	126
S43830001	C5 -153-7	28	S44608101	C8 -138	34	S47115001	C10-122	38	S49957000	F -18	58
S43830001	Ga3-153-7	122	S44611001	A2 -113	4	S47115001	C14-122	46	S49958000	F -49	58
S43833109	AA1-1	104	S44616001	C9 -17	36	S47224001	C1 -207	20	S49959001	F -14	58
S43834109	AA1-1-1	104	S44624000	C10-120	38	S47270001	B2 -122	16	S49980001	J -53-10	66

CODE	REF.NO	Page	CODE	REF.NO	Page	CODE	REF.NO	Page	CODE	REF.NO	Page
S49980001	Ga1-FM	118	S51061001	Ga5-153-3	126	S54145001	A3 -35	8	S55192000	Z -1-1	114
S49982000	F -12	58	S51062001	C15-153-4	48	S54393001	D2 -55	52	S55197001	B2 -118	16
S49983000	F -20	58	S51062001	Ga5-153-4	126	S55103101	B1 -1	12	S55198000	B2 -111	16
S49984000	F -21	58	S51063001	C15-153-3	48	S55104001	B1 -4	12	S55199001	L -41	70
S49992000	F -1	58	S51063001	Ga5-153-3	126	S55105001	B1 -16-1	12	S55200001	D1 -5	50
S49994001	J -38	64	S51064001	C15-153-4	48	S55111001	M1 -17	72	S55203001	C2 -41	22
S49995001	F -53	58	S51064001	Ga5-153-4	126	S55131001	D1 -23	50	S55203001	C9 -41	36
S50048000	M2 -3-1	72	S51065001	C15-153-3	48	S55132001	C1 -1-1-24	18	S55204001	C2 -17	22
S50049000	M2 -7	72	S51065001	Ga5-153-3	126	S55133000	K -10	68	S55205001	C2 -49	22
S50050000	M2 -6	72	S51066001	C15-153-4	48	S55137001	L -19	70	S55205001	C9 -49	36
S50051000	M2 -5	72	S51066001	Ga5-153-4	126	S55138001	C2 -16	22	S55206001	W -2	94
S50052000	M2 -3	72	S51077001	Y2 -14	102	S55140001	E -29	56	S55208000	A1 -27	2
S50529000	F -36	58	S51077001	Ga6-14	130	S55141001	C3 -68	24	S55208000	A2 -27	4
S50529000	F -38	58	S51078101	Y2 -15	102	S55142001	C3 -67	24	S55208000	A3 -27	8
S50558000	F -3	58	S51078101	Ga6-15	130	S55143001	C3 -70	24	S55210001	C2 -36	22
S50661009	P -40-1	80	S51241000	T -1-22	88	S55144001	D2 -54	52	S55210001	C9 -36	36
S50662009	P -40-2	80	S51282001	Z -34-3	115	S55145001	B1 -2	12	S55211000	C2 -29	22
S50671000	Q -1	82	S51283001	Z -34-1	115	S55147001	C1 -1-1-12	18	S55211000	C9 -29	36
S50672000	Q -2	82	S51436001	AA4-7	110	S55148002	K -24	68	S55213001	E -9	54
S50673000	C2 -37	22	S51449001	J -53-12	66	S55149100	K -5	68	S55214000	E -28	56
S50673000	C9 -37	36	S51449001	Ga1-A-F	118	S55150000	K -8	68	S55215001	E -19	54
S51027001	C12-1	42	S51471101	AA4-7-1	110	S55151000	K -9	68	S55216101	E -14-1	54
S51028000	C12-1-1	42	S51472001	AA4-7-1-1	110	S55151000	T -1-18	88	S55217201	E -14	54
S51029001	C12-3	42	S51473000	AA4-7-1-2	110	S55152001	A1 -15	2	S55402200	T -1-4	88
S51030001	C12-6	42	S51474000	AA4-7-1-2-1	110	S55152001	A2 -15	4	S55476002	D1 -37	50
S51030001	Ga5-6	126	S51476001	AA4-7-1-4	110	S55152001	A3 -15	8	S55476002	D1 -37	50
S51031001	C12-7	42	S51477001	AA4-7-1-7	110	S55154001	T -1-1	88	S55476002	N -4	75
S51031001	Ga5-7	126	S51480009	AA4-7-3	110	S55155000	T -1-1-1	88	S55479001	F -63	58
S51033001	C13-17	44	S51481009	AA4-7-3-1	110	S55157000	D1 -14	50	S55481002	Q -6	82
S51034101	C13-23	44	S51482000	AA4-7-3-2	110	S55160001	W -1-1	94	S55485002	C3 -87	24
S51040001	C14-130	46	S51488000	AA4-7-1-11	110	S55161001	C5 -149	28	S55486001	A1 -51	2
S51041001	C14-133	46	S51804001	C5 -154	28	S55161001	C11-149	40	S55486001	A2 -51	4
S51042001	C13-5	44	S51804001	C11-154	40	S55161001	Ga3-149	122	S55486001	A3 -51	8
S51042001	Ga5-5	126	S51804001	C15-154	48	S55161001	Ga4-149	124	S55533000	C12-1-5	42
S51048101	C15-151-1	48	S51804001	Ga3-154	122	S55162001	C1 -140	20	S55572001	B1 -11	12
S51048101	Ga5-151-1	126	S51804001	Ga4-154	124	S55162001	Ga2-140-1	120	S55572001	B2 -127	16
S51049101	C15-151-2	48	S51804001	Ga5-154	128	S55163001	C1 -140	20	S55632001	Q -32-3	82
S51049101	Ga5-151-2	126	S52582001	S -50	86	S55163001	Ga2-140-2	120	S55633001	Z -98	116
S51050101	C15-151-3	48	S52744000	Q -14-1	82	S55164001	C5 -150-1	28	S55658000	E -27	56
S51050101	Ga5-151-3	126	S52836000	B2 -126	16	S55164001	Ga2-150-1	120	S55659000	F -56	58
S51051001	C15-153-1	48	S53070001	AA4-8-3	110	S55165001	C5 -150-2	28	S55663001	Z -23	115
S51051001	Ga5-153-1	126	S53071001	AA4-8-1	110	S55165001	Ga2-150-2	120	S55877001	B1 -12-1-3	12
S51052001	C15-153-2	48	S53072001	AA4-8-3-1	110	S55166001	C5 -150-3	28	S55877001	B1 -12-3-3	12
S51052001	Ga5-153-2	126	S53073001	AA4-8-3-2	110	S55166001	Ga2-150-3	120	S55916201	Q -51	84
S51053001	C15-153-1	48	S53074001	AA4-8-3-4	110	S55167001	C2 -23	22	S55917000	B2 -125	16
S51053001	Ga5-153-1	126	S53075001	AA4-8-3-6	110	S55169101	D1 -28	50	S55919001	W -1	94
S51054001	C15-153-2	48	S53076001	AA4-8-3-9	110	S55170001	D1 -29	50	S55920001	W -1	94
S51054001	Ga5-153-2	126	S53077001	AA4-8-3-11	110	S55171001	D1 -21	50	S55921001	W -1-1	94
S51055001	C15-153-1	48	S53078001	AA4-8-3-14	110	S55172001	D1 -24	50	S55925101	Z -1	114
S51055001	Ga5-153-1	126	S53079001	AA4-8-3-16	110	S55173000	F -32	58	S55925102	Z -1	114
S51056001	C15-153-2	48	S53080001	AA4-9-1	112	S55174000	F -62	58	S55926001	A1 -30	2
S51056001	Ga5-153-2	126	S53081001	AA4-9-1-1	112	S55177001	J -26	64	S55928000	A2 -18	4
S51057001	C15-153-1	48	S53082001	AA4-9-3	112	S55178001	J -26-1	64	S55929001	A2 -30	4
S51057001	Ga5-153-1	126	S53154001	AA4-8	110	S55179001	F -31	58	S55930001	A2 -115	4
S51058001	C15-153-2	48	S53155001	AA4-9	112	S55180001	F -61	58	S55930001	A3 -123	8
S51058001	Ga5-153-2	126	S53207001	E -8	54	S55181001	M1 -1	72	S55931001	C8 -6	34
S51059001	C15-153-3	48	S53884001	R -1	86	S55183000	M1 -1-1	72	S55932001	C8 -7	34
S51059001	Ga5-153-3	126	S53889000	N -10	75	S55184000	Q -29	82	S55933100	C9 -16	36
S51060001	C15-153-4	48	S53890000	N -11	75	S55191000	A1 -13	2	S55934101	C9 -23	36
S51060001	Ga5-153-4	126	S54145001	A1 -35	2	S55191000	A2 -13	4	S55935001	C10-67	38
S51061001	C15-153-3	48	S54145001	A2 -35	4	S55192000	Z -1-1	114	S55936001	C10-68	38

索引 / INDEX

CODE	REF.NO	Page	CODE	REF.NO	Page	CODE	REF.NO	Page	CODE	REF.NO	Page
S55937001	C10-70	38	S56537001	Ga5-141	126	S57858001	Ga6-1-10	130	S59890001	X -3-5	98
S55939001	C10-133	38	S56538001	C15-138	48	S57859001	Y2 -1-4	102	S59890001	X -4-2	98
S55940001	C8 -140-1	34	S56538001	Ga5-138	126	S57859001	Ga6-1-4	130	S59890001	X -5-2	98
S55940001	C13-139	44	S56539001	A2 -111	4	S57860001	Y2 -1-5	102	S59891001	K -25	68
S55941001	C8 -140-2	34	S56671001	Q -9	82	S57860001	Ga6-1-5	130	S59892001	AA4-8-3-13	110
S55944001	A3 -30	8	S57711001	B2 -10	16	S57925001	A1 -25	2	S59893001	C3 -220	24
S55945001	A3 -125	10	S57712000	B2 -10-1	16	S57925001	A2 -25	4	S59893001	C3 -223	24
S55946000	C13-16	44	S57718001	C8 -140-3	34	S57925001	A3 -25	8	S59893001	C10-220	38
S55947001	C13-28	44	S57719001	C8 -140-4	34	S57926000	Q -21	82	S59893001	C10-223	38
S55948001	C13-33	44	S57720001	C11-150-4	40	S57952001	C6 -157	30	S59893001	C14-220	46
S55949001	C14-67	46	S57720001	Ga4-150-4	124	S57952001	C11-157	40	S59893001	C14-223	46
S55950001	C14-68	46	S57721001	C11-150-5	40	S57952001	C15-155	48	S59893001	J -12	64
S55951001	C14-70	46	S57721001	Ga4-150-5	124	S57952001	X -2	98	S59893001	K -6	68
S55952001	C13-140-1	44	S57722001	C11-150-6	40	S57952001	Ga2-157	120	S59894001	Y1 -1-1-5	100
S55952001	Ga5-140-1	126	S57722001	Ga4-150-6	124	S57952001	Ga4-157	124	S59898001	Q -52	84
S55953001	C13-140-2	44	S57723001	C11-150-1	40	S57952001	Ga5-155	128	SA0037000	N -1-28-6	74
S55953001	Ga5-140-2	126	S57723001	Ga4-150-1	124	S57955001	X -6-3	98	SA0049001	J -22-4	64
S55954001	C15-149	48	S57724001	C11-150-2	40	S57957001	X -6-4	98	SA1034000	N -1-28-10	74
S55954001	Ga5-149	126	S57724001	Ga4-150-2	124	S57964000	F -26	58	SA1462001	AA4-7-1-10	110
S55966001	B1 -16-2	12	S57725001	C11-150-3	40	S57965000	E -14-9	54	SA1587001	H -1-1	62
S55970001	B1 -16-3	12	S57725001	Ga4-150-3	124	S57965000	E -14-10	54	SA1645019	Z -17	114
S56018000	B2 -10-2	16	S57726001	C11-151-1	40	S57968001	F -66	58	SA1645019	Z -17	114
S56019001	B2 -10-3	16	S57726001	Ga4-151-1	124	S58200000	W -44	96	SA1645025	Z -17	114
S56151101	T -1-3	88	S57727001	C11-151-2	40	S58851001	T -1	88	SA1752016	Z -17	114
S56154101	N -1	74	S57727001	Ga4-151-2	124	S59103001	D2 -41	52	SA1890001	E -22	54
S56166000	Q -9	82	S57728001	C11-151-3	40	S59134001	B1 -12-3	12	SA2173001	E -22	54
S56167000	Q -9-1	82	S57728001	Ga4-151-3	124	S59221001	E -24	54	SA2382001	F -50	58
S56167001	Q -9-1	82	S57729001	C11-153-1	40	S59222001	E -24	54	SA2423001	C1 -1-1-8	18
S56167002	Q -9-2	82	S57729001	Ga4-153-1	124	S59331001	C10-130	38	SA2424001	C1 -1-1-7	18
S56167002	Q -9-2	82	S57730001	C11-153-2	40	S59407001	F -40	58	SA2425001	C1 -1-1-26	18
S56168000	Q -50-1	84	S57730001	Ga4-153-2	124	S59637001	C3 -13	24	SA2427001	C1 -1-1-25	18
S56168001	Q -50-2	84	S57731001	C11-153-3	40	S59637001	C3 -226-1	24	SA2428001	C1 -1-1	18
S56168002	Q -50-3	84	S57731001	Ga4-153-3	124	S59637001	C10-13	38	SA2900001	G -21	60
S56168003	Q -50-4	84	S57732001	C11-153-4	40	S59637001	C10-226-1	38	SA2901001	J -9	64
S56169000	Q -14	82	S57732001	Ga4-153-4	124	S59637001	C12-13	42	SA2902001	J -1	64
S56170100	Q -32	82	S57733001	C11-153-5	40	S59637001	C14-226-1	46	SA2903001	L -20	70
S56171000	Q -32-1	82	S57733001	Ga4-153-5	124	S59650001	C13-44	44	SA2904001	J -22	64
S56172000	Q -53	84	S57734001	C11-153-6	40	S59652000	S -1-9	86	SA2907001	J -45-3	66
S56173000	Q -31	82	S57734001	Ga4-153-6	124	S59695000	P -10	78	U32744000	R -1-9	86
S56241101	N -H-1	76	S57735001	C11-153-7	40	S59741000	C3 -226	24	U34870001	T -1-3-3	88
S56242101	N -H-2	76	S57735001	Ga4-153-7	124	S59742000	C10-226	38	U85274000	N -11-1	75
S56243101	N -H-3	76	S57835101	C14-97	46	S59742000	C14-226	46	UA4817000	N -10-1	75
S56244101	N -H-4	76	S57836000	Q -1	82	S59743001	F -68	58			
S56246101	N -H-5	76	S57844001	C15-150-1	48	S59763000	D1 -27	50			
S56247101	N -H-6	76	S57844001	Ga5-150-1	126	S59871001	J -22-2	64			
S56248101	N -H-7	76	S57845001	C15-150-2	48	S59872001	J -22-1	64			
S56249101	N -H-8	76	S57845001	Ga5-150-2	126	S59873001	J -22-3	64			
S56525000	F -48	58	S57846001	C15-150-3	48	S59890001	C2 -12-3	22			
S56526000	F -55	58	S57846001	Ga5-150-3	126	S59890001	C2 -35	22			
S56527001	A1 -50	2	S57849101	C15-156	48	S59890001	C2 -93	22			
S56527001	A2 -50	4	S57849101	Ga5-156	128	S59890001	C3 -123	24			
S56527001	A3 -50	8	S57850001	C13-38	44	S59890001	C3 -136	24			
S56530000	A3 -13	8	S57851001	Y2 -1	102	S59890001	C9 -12-3	36			
S56531001	M2 -1	72	S57853001	Y2 -1-1	102	S59890001	C9 -35	36			
S56532001	M2 -4	72	S57854001	Y2 -1-1-3	102	S59890001	C9 -93	36			
S56533101	M2 -10	72	S57855001	Y2 -1-1-4	102	S59890001	C10-123	38			
S56534001	C13-73	44	S57856001	Y2 -1-2	102	S59890001	C10-136	38			
S56535001	C13-85	44	S57856001	Ga6-1-2	130	S59890001	C12-12-3	42			
S56536001	C13-78	44	S57857001	Y2 -16	102	S59890001	C12-93	42			
S56536001	Ga5-78	126	S57857001	Ga6-16	130	S59890001	C14-123	46			
S56537001	C13-141	44	S57858001	Y2 -1-10	102	S59890001	C14-136	46			

brother®

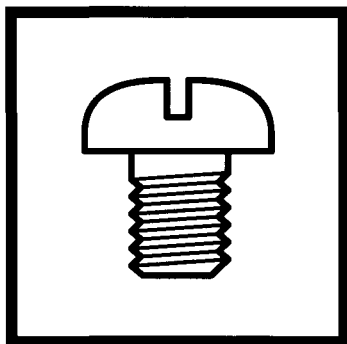

パーツブック
PARTS BOOK

ブラザー工業株式会社

〒467-8561 名古屋市瑞穂区苗代町 15 番 1 号 TEL (052) 824-2392

BROTHER INDUSTRIES, LTD

15-1, Naeshiro-cho, Mizuho-ku, Nagoya 467-8561, Japan. Phone : 81-52-824-2177

Printed in Japan

BAS-311F, 326F
SA2974-001
2003.07.ZB(1)

From the library of: Superior Sewing Machine & Supply LLC